

GT6430D-01/02

GT6430D-01/02
INSTRUCTION MANUAL

**ELECTRONIC DIRECT DRIVE LOCKSTITCH BAR TACKER
ELECTRONIC DIRECT DRIVE LOCKSTITCH BUTTON SEWER**

**ELECTRONIC DIRECT DRIVE LOCKSTITCH BAR TACKER
ELECTRONIC DIRECT DRIVE LOCKSTITCH BUTTON SEWER**



This machine may only be operated by adequately trained operators only after having completely read and understood the instruction manual.

Parts are subject to changes in design without prior notice.



XI'AN TYPICAL INDUSTRIES CO., LTD.
No. 335, South Taibai Road
Xi'an 710068, P.R.China
Tel.: +86-29-88279093 // 88279150 // 88279151
Fax: +86-29-88249715 // 88245215

E-mail: tic@chinatypical.com
www.chinatypical.com

Vetron Typical Europe GmbH
Clara-Immerwahr-Str. 6
67661 Kaiserslautern, Germany
Tel. +49 6301 320 75-0
Fax +49 6301 320 75-11

info@vetrontypical.com
www.vetrontypical.com

GC672-Series – Manual – EN – 08-2010

TYPICAL

1. Lugares a lubricar

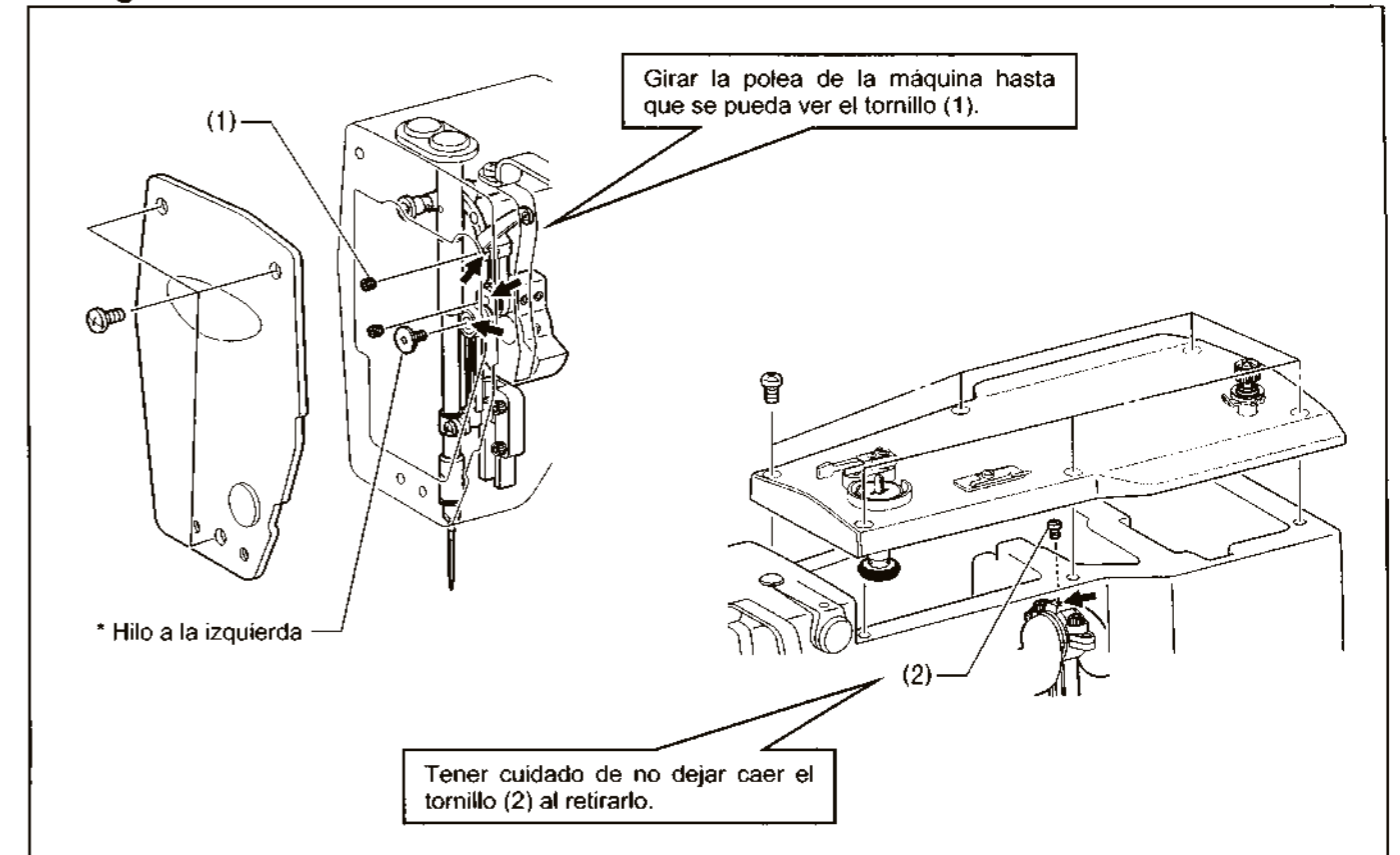

2. Reposición del contador de lubricación

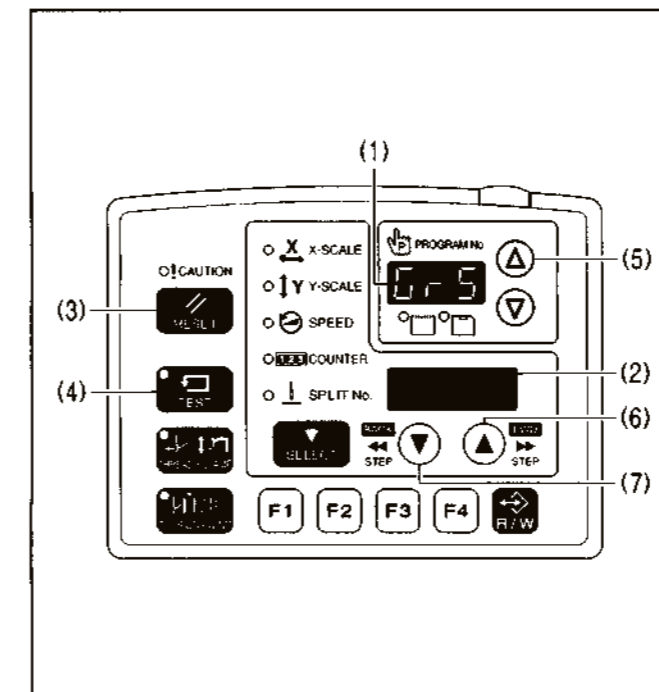

Una vez que se haya lubricado, siga el procedimiento indicado a continuación para reponer el número de puntadas acumuladas entre las lubricaciones.

1. Conectar el interruptor de alimentación. "GrE" y "AS.UP" destellarán en la exhibición PROGRAM No. (1) y en el menú (2) y sonará el zumbador.
2. Presionar la tecla RESET (3). La exhibición PROGRAM No. (1) y el menú (2) volverán a sus exhibiciones originales.
3. Mientras se presiona la tecla TEST (4), presionar la tecla Δ (5). Aparecerá "GrS" en la exhibición PROGRAM No. (1), y el número acumulado de puntadas hasta la próxima lubricación aparecerá en el menú (2) en unidades de 100.000 puntadas. (El número de puntadas será exhibido en los siete dígitos de la exhibición PROGRAM No. (1) y el menú (2) en unidades de 100 puntadas mientras se presiona la tecla Δ (6).)
4. Pulsar la tecla ∇ (7). El número de puntadas acumuladas se repondrá a "0000".
5. Presionar y sostiene la tecla RESET (3) durante 2 segundos o más. (De esta manera se completa el procedimiento de reposición.)
6. Cuando se pulse la tecla TEST (4), las exhibiciones volverán a sus estados normales.

1. Grease application locations

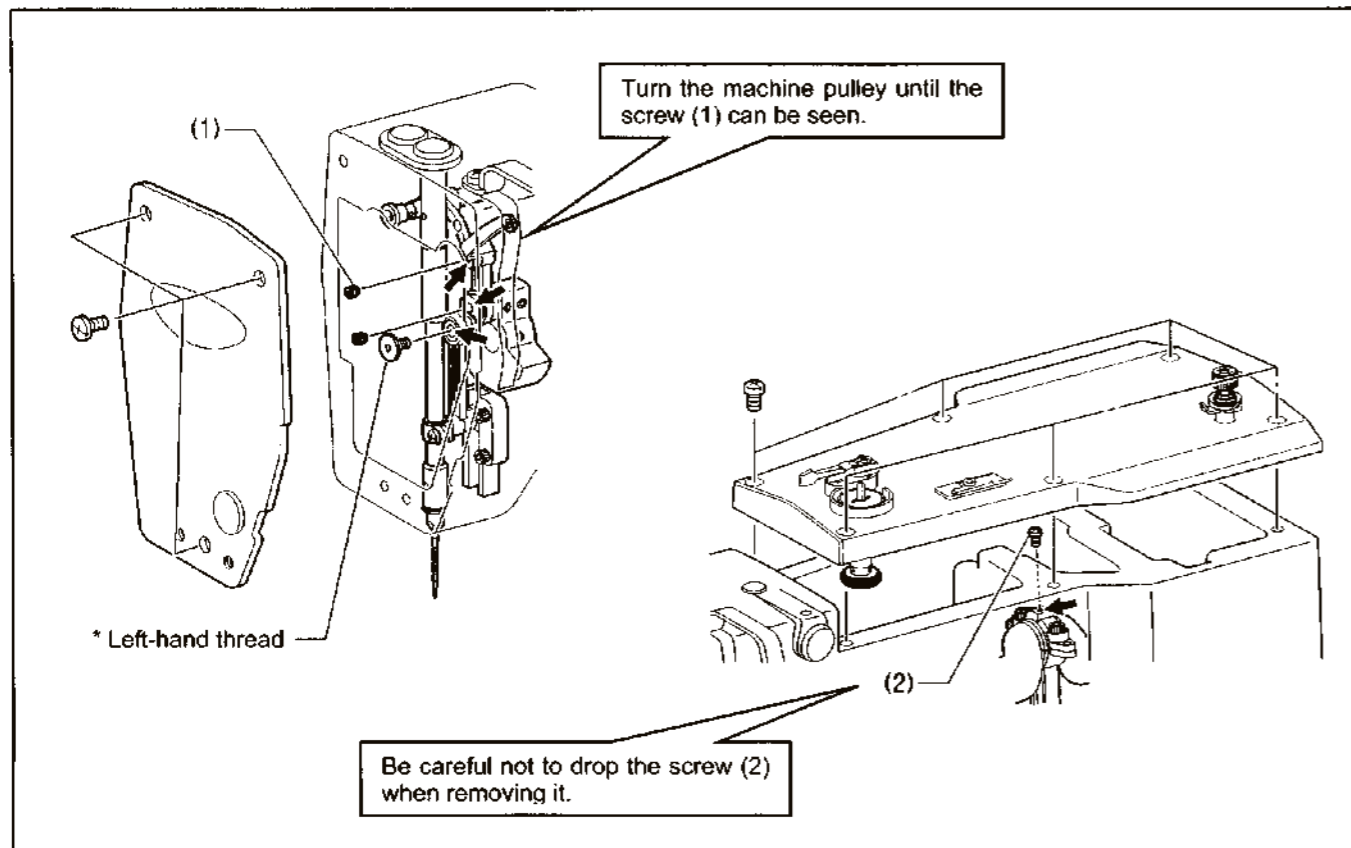

2. Resetting the grease up counter

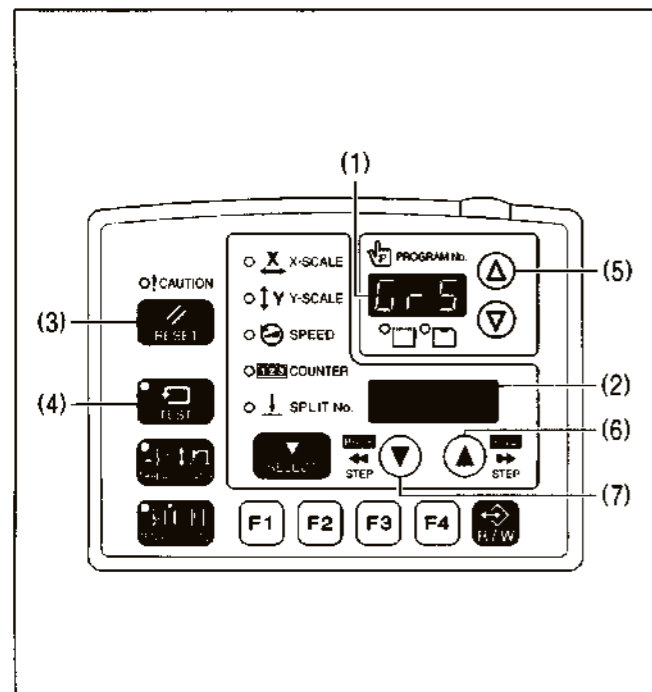

Once the grease has been applied, follow the procedure below to reset the cumulative number of stitches between grease applications.

1. Turn on the power switch. "GrE" and "AS.UP" will flash in the program No. display (1) and the menu display (2) and the buzzer will sound.
2. Press the RESET key (3). The program No. display (1) and the menu display (2) will return to their normal displays.
3. While pressing the TEST key (4), press the ▲ key (5). "GrS" will appear in the program No. display (1), and the cumulative number of stitches until greasing is required will appear in the menu display (2) in units of 100,000 stitches.
(The number of stitches will be displayed in all seven digits of the program No. display (1) and menu display (2) in units of 100 stitches while the ▲ key (6) is being pressed.)
4. Press the ▼ key (7). The cumulative number of stitches will be reset to "0000".
5. Press and hold the RESET key (3) for 2 seconds or more. (This completes the reset procedure.)
6. When you press the TEST key (4), the displays will return to their normal displays.

1. 润滑脂添加部位

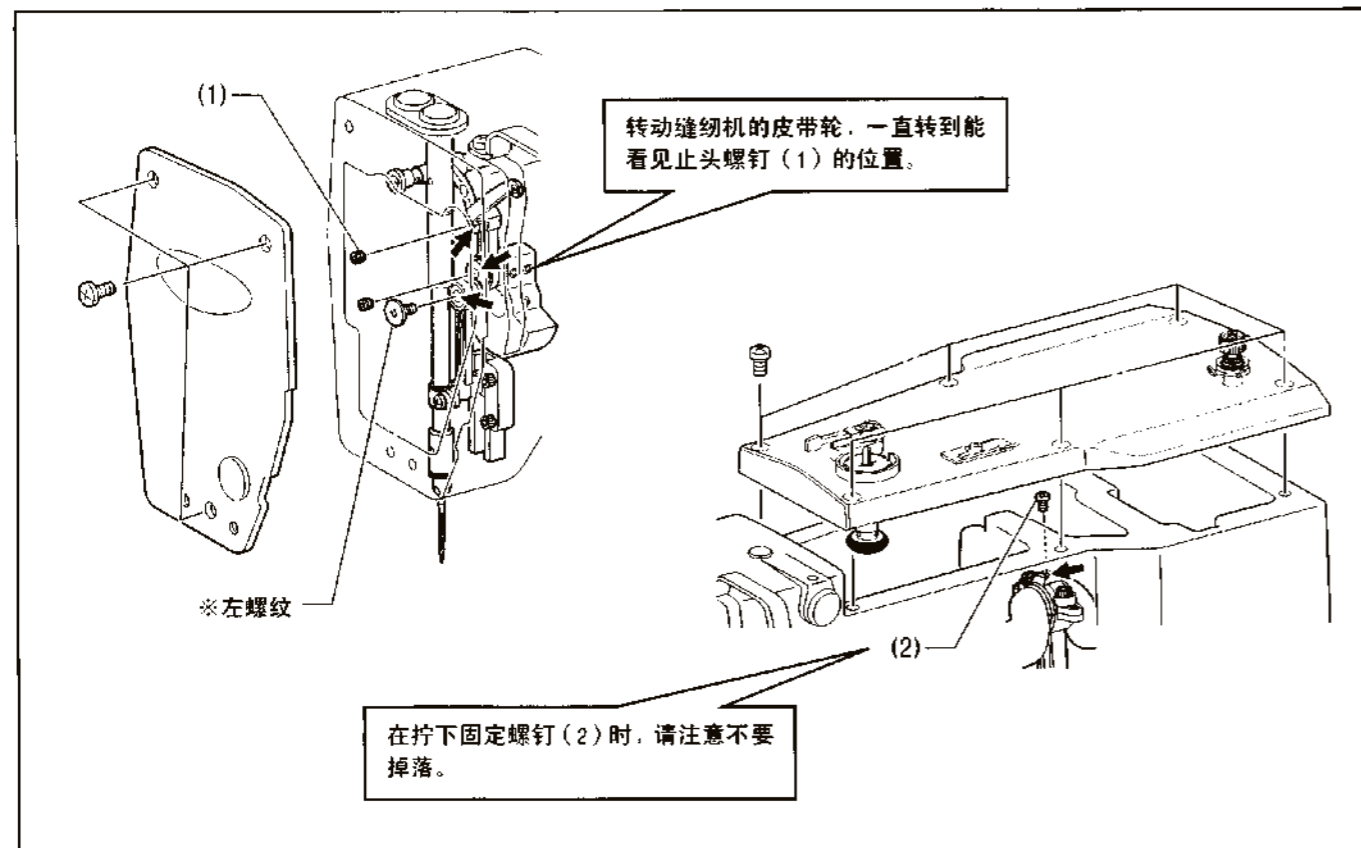

2. 润滑脂添加计数器的复位方法

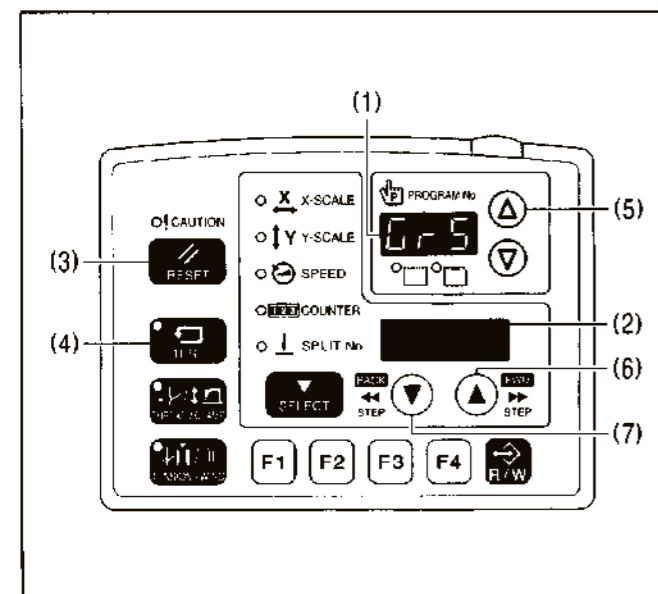

在确实添加润滑脂后，按照下述步骤进行复位操作，以清除润滑脂添加前的累计针数。

1. 打开电源。程序号(No.)表示(1)和菜单表示(2)所显示的“GrE”、“AS.UP”将闪烁，蜂鸣器鸣响。
2. 按 RESET 键(3)。程序号(No.)表示(1)和菜单表示(2)将变为通常的显示状态。
3. 在按 TEST 键(4)的同时按 Δ 键(5)。程序号(No.)表示(1)将显示“GrS”，菜单表示(2)将以 10 万针为单位显示润滑脂添加前的累计针数。
(在按着 Δ 键(6)时，程序号(No.)表示(1)和菜单表示(2)将以 100 针为单位显示 7 位的合计值。)
4. 按 ∇ 键(7)。累计针数显示值变为“0000”。
5. 按住 RESET 键(3)2 秒钟或更长的时间。(复位操作完成。)
6. 如果按 TEST 键(4)，显示将返回到通常的状态。

ELECTRONIC DIRECT DRIVE LOCKSTITCH
BAR TACKER

ELECTRONIC DIRECT DRIVE LOCKSTITCH
BUTTON SEWER

Thank you very much for buying a SUPREME sewing machine. Before using your new machine, please read the safety instructions below and the explanations given in the instruction manual.

With industrial sewing machines, it is normal to carry out work while positioned directly in front of moving parts such as the needle and thread take-up lever, and consequently there is always a danger of injury that can be caused by these parts. Follow the instructions from training personnel and instructors regarding safe and correct operation before operating the machine so that you will know how to use it correctly.



SAFETY INSTRUCTIONS

1. Safety indications and their meanings



This instruction manual and the indications and symbols that are used on the machine itself are provided in order to ensure safe operation of this machine and to prevent accidents and injury to yourself or other people.

The meanings of these indications and symbols are given below.

Indications

 DANGER	The instructions which follow this term indicate situations where failure to follow the instructions will almost certainly result in death or severe injury.
 CAUTION	The instructions which follow this term indicate situations where failure to follow the instructions could cause injury when using the machine or physical damage to equipment and surroundings.

Symbols

-  This symbol (△) indicates something that you should be careful of. The picture inside the triangle indicates the nature of the caution that must be taken.
(For example, the symbol at left means "beware of injury".)
-  This symbol (⊘) indicates something that you must not do.
-  This symbol (●) indicates something that you must do. The picture inside the circle indicates the nature of the thing that must be done.
(For example, the symbol at left means "you must make the ground connection".)







2. Notes on safety

DANGER











-  Wait at least 5 minutes after turning off the power switch and disconnecting the power cord from the wall outlet before opening the face plate of the control box. Touching areas where high voltages are present can result in severe injury.

CAUTION

Environmental requirements









-  Use the sewing machine in an area which is free from sources of strong electrical noise such as high-frequency welders. Sources of strong electrical noise may cause problems with correct operation.
-  Any fluctuations in the power supply voltage should be within $\pm 10\%$ of the rated voltage for the machine. Voltage fluctuations which are greater than this may cause problems with correct operation.
-  The power supply capacity should be greater than the requirements for the sewing machine's electrical consumption. Insufficient power supply capacity may cause problems with correct operation.
-  The ambient temperature should be within the range of 5°C to 35°C during use. Temperatures which are lower or higher than this may cause problems with correct operation.
-  The relative humidity should be within the range of 45% to 85% during use, and no dew formation should occur in any devices. Excessively dry or humid environments and dew formation may cause problems with correct operation.
-  Avoid exposure to direct sunlight during use. Exposure to direct sunlight may cause problems with correct operation.
-  In the event of an electrical storm, turn off the power and disconnect the power cord from the wall outlet. Lightning may cause problems with correct operation.

Installation



-  Machine installation should only be carried out by a qualified technician.
-  Contact your Brother dealer or a qualified electrician for any electrical work that may need to be done.
-  The sewing machine weighs approximately 56 kg. The installation should be carried out by two or more people.
-  Do not connect the power cord until installation is complete, otherwise the machine may operate if the foot switch is depressed by mistake, which could result in injury.
-  Hold the machine head with both hands when tilting it back or returning it to its original position. Furthermore, after tilting back the machine head, do not push the face plate side or the pulley side from above, as this could cause the machine head to topple over, which may result in personal injury or damage to the machine.
-  Be sure to connect the ground. If the ground connection is not secure, you run a high risk of receiving a serious electric shock, and problems with correct operation may also occur.
-  All cords should be secured at least 25 mm away from any moving parts. Furthermore, do not excessively bend the cords or secure them too firmly with staples, otherwise there is the danger that fire or electric shocks could occur.
-  Install the safety covers to the machine head and motor.
-  If using a work table which has casters, the casters should be secured in such a way so that they cannot move.
-  Be sure to wear protective goggles and gloves when handling the lubricating oil and grease, so that they do not get into your eyes or onto your skin, otherwise inflammation can result. Furthermore, do not drink the oil or eat the grease under any circumstances, as they can cause vomiting and diarrhoea. Keep the oil out of the reach of children.

CAUTION









Sewing

-  This sewing machine should only be used by operators who have received the necessary training in safe use beforehand.
-  The sewing machine should not be used for any applications other than sewing.
-  Be sure to wear protective goggles when using the machine. If goggles are not worn, there is the danger that if a needle breaks, parts of the broken needle may enter your eyes and injury may result.
-  Turn off the power switch at the following times, otherwise the machine may operate if the foot switch is depressed by mistake, which could result in injury.
 - When threading the needle
 - When replacing the needle and bobbin
 - When not using the machine and when leaving the machine unattended
-  If using a work table which has casters, the casters should be secured in such a way so that they cannot move.
-  Attach all safety devices before using the sewing machine. If the machine is used without these devices attached, injury may result.
-  Do not touch any of the moving parts or press any objects against the machine while sewing, as this may result in personal injury or damage to the machine.
-  If an error occurs in machine operation, or if abnormal noises or smells are noticed, immediately turn off the power switch. Then contact your nearest Brother dealer or a qualified technician.
-  If the machine develops a problem, contact your nearest Brother dealer or a qualified technician.

Cleaning

-  Turn off the power switch before carrying out cleaning, otherwise the machine may operate if the foot switch is depressed by mistake, which could result in injury.
-  Be sure to wear protective goggles and gloves when handling the lubricating oil and grease, so that they do not get into your eyes or onto your skin, otherwise inflammation can result. Furthermore, do not drink the oil or eat the grease under any circumstances, as they can cause vomiting and diarrhoea. Keep the oil out of the reach of children.

Maintenance and inspection

-  Maintenance and inspection of the sewing machine should only be carried out by a qualified technician.
-  Ask your Brother dealer or a qualified electrician to carry out any maintenance and inspection of the electrical system.
-  Turn off the power switch and disconnect the power cord from the wall outlet at the following times, otherwise the machine may operate if the foot switch is depressed by mistake, which could result in injury.
 - When carrying out inspection, adjustment and maintenance
 - When replacing consumable parts such as the rotary hook
-  If the power switch needs to be left on when carrying out some adjustment, be extremely careful to observe all safety precautions.
-  Hold the machine head with both hands when tilting it back or returning it to its original position. Furthermore, after tilting back the machine head, do not push the face plate side or the pulley side from above, as this could cause the machine head to topple over, which may result in personal injury or damage to the machine.
-  Use only the proper replacement parts as specified by Supreme.
-  If any safety devices have been removed, be absolutely sure to re-install them to their original positions and check that they operate correctly before using the machine.
-  Any problems in machine operation which result from unauthorized modifications to the machine will not be covered by the warranty.

3. Warning labels

The following warning labels appear on the sewing machine. Please follow the instructions on the labels at all times when using the machine. If the labels have been removed or are difficult to read, please contact your nearest Brother dealer.

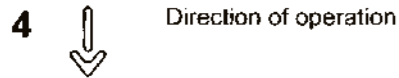
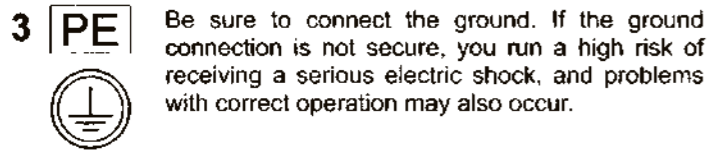
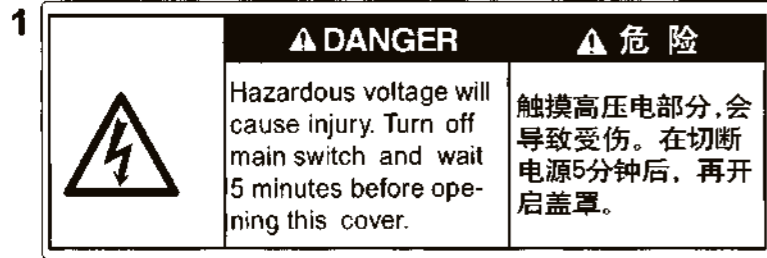

- Safety devices
- Eye guard
 - Finger guard
 - Tension release solenoid cover
 - Thread take-up cover
 - Frame side cover
 - Back cover, etc.

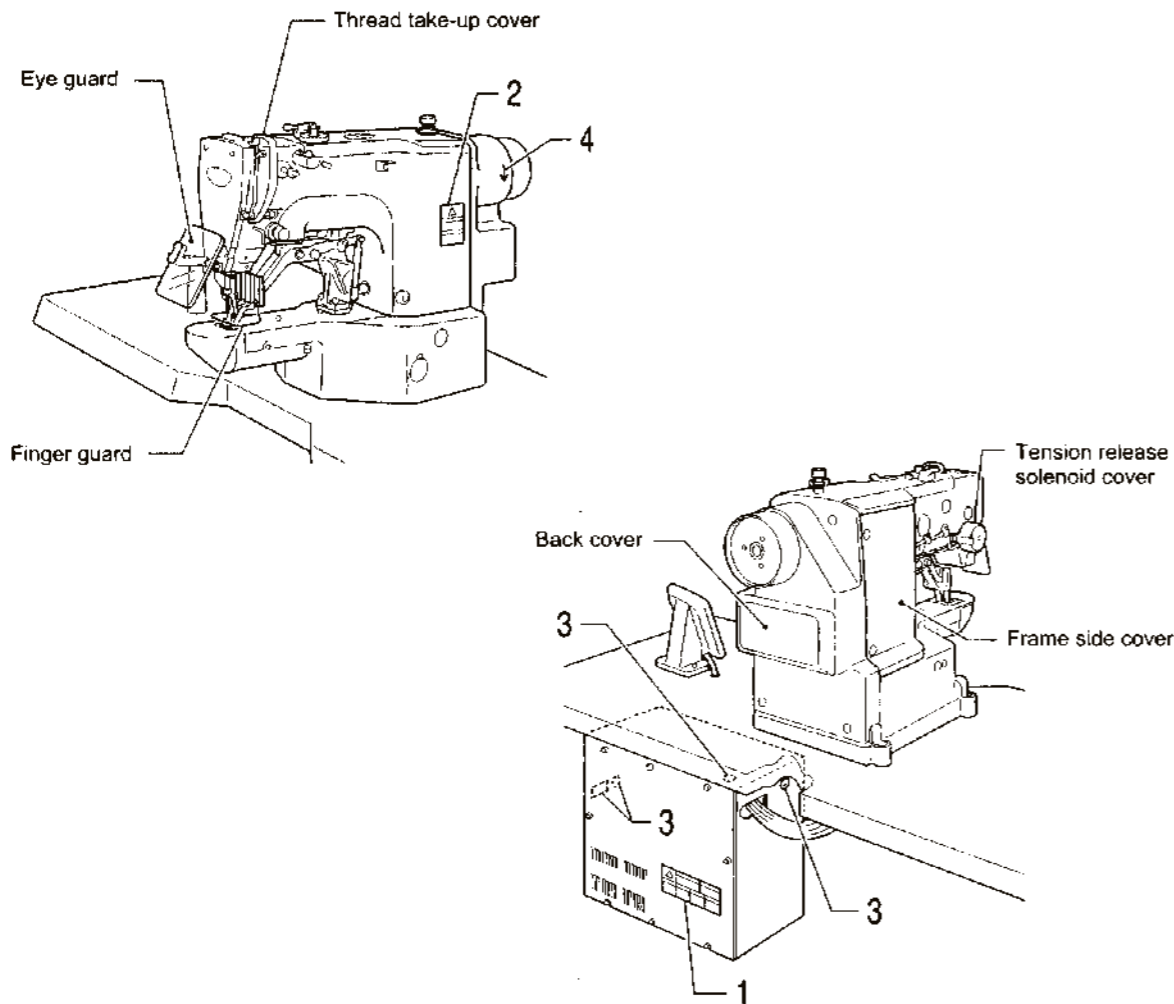

CONTENTS

1. NAMES OF MAJOR PARTS	1	5. USING THE OPERATION PANEL (BASIC OPERATIONS)	29
2. SPECIFICATIONS	2	5-1. Name and function of each operation panel item	29
2-1. Machine specifications	2	5-2. Setting the program number	31
2-2. Program list (CSM-430D).....	3	5-3. Setting the X-scale and Y-scale.....	31
2-3. Program list (CSM-438D).....	8	5-4. Setting the sewing speed.....	31
3. INSTALLATION	11	5-5. Checking the sewing pattern	32
3-1. Table processing diagram	11	5-6. Checking the sewing pattern	33
3-2. Installing the control box	12	5-7. Adjusting the work clamp / button clamp lift amount	34
3-3. Installing the oil pan	12	6. USING THE OPERATION PANEL (ADVANCED OPERATIONS)	35
3-4. Installing the machine head	13	6-1. List of advanced functions	35
3-5. Installing the operation panel	14	6-2. Setting memory switches.....	36
3-6. Installing the treadle unit	14	6-3. List of memory switches	37
3-7. Installing the cotton stand	15	6-4. Using the lower thread counter.....	38
3-8. Installing the button tray	15	6-5. Using the production counter.....	39
3-9. Installing the eye guard	15	6-6. Using user programs	40
3-10. Connecting the cords	16	6-7. Using cycle programs	43
3-11. Connecting the ground wire	18	6-8. Direct selection	46
3-12. Installing the back cover.....	18	6-9. Loading additional sewing data	46
3-13. Lubrication.....	19	7. SEWING	47
3-14. Starting up.....	20	8. MAINTENANCE	48
4. PREPARATION BEFORE SEWING	21	8-1. Cleaning the rotary hook.....	48
4-1. Installing the needle	21	8-2. Cleaning the control box air inlet ports	49
4-2. Threading the upper thread.....	21	8-3. Draining the oil.....	49
4-3. Winding the lower thread	23	8-4. Cleaning the eye guard.....	49
4-4. Installing the bobbin case.....	24	8-5. Checking the needle.....	49
4-5. Thread tension	24	8-6. Lubrication	49
4-5-1. Lower thread tension	24	8-7. Applying grease (When "GREASEUP" appears).....	50
4-5-2. Upper thread tension	25	9. TABLE OF ERROR CODES	52
4-6. Thread nipper device	26		
4-7. Inserting the button	28		
4-8. Adjusting the button clamp	28		
4-9. Installing the accessory spring	28		

1. NAMES OF MAJOR PARTS

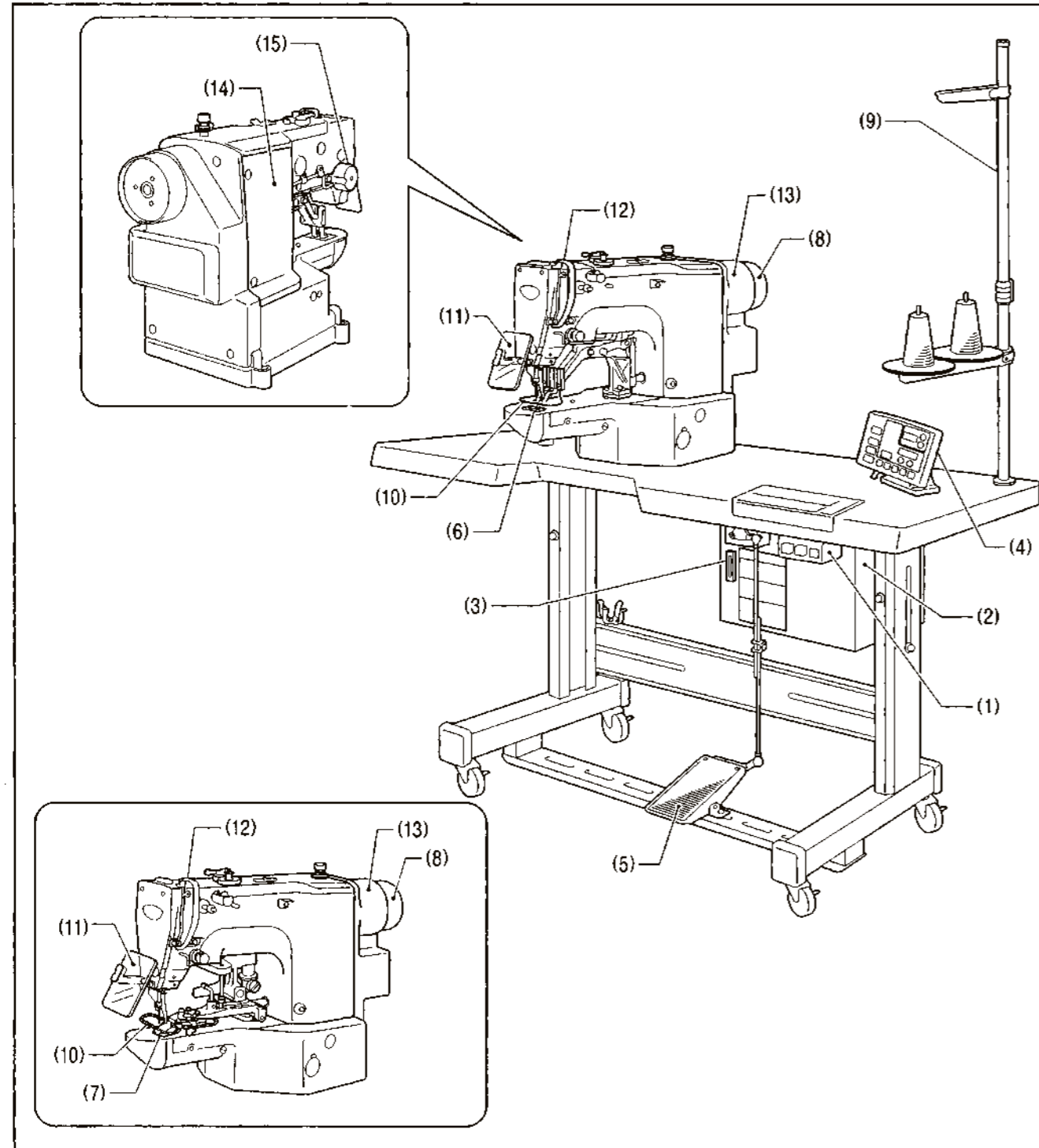

- (1) Power switch
- (2) Control box
- (3) CF slot
- (4) Operation panel
- (5) Foot switch
- (6) Work clamp
- (7) Button clamp
- (8) Pulley
- (9) Cotton stand

- Safety devices**
- (10) Finger guard
 - (11) Eye guard
 - (12) Thread take-up cover
 - (13) Back cover
 - (14) Frame side cover
 - (15) Tension release solenoid cover

2. SPECIFICATIONS

2-1. Machine specifications

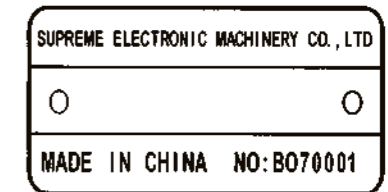
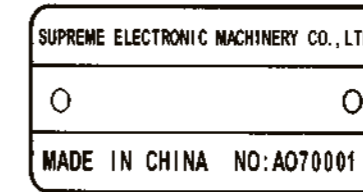
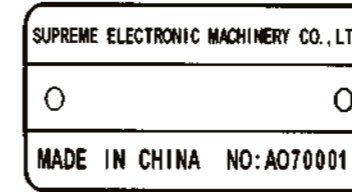

	Electronic direct drive lockstitch bar tacker	Electronic direct drive lockstitch button sewer
Stitch formation	Single needle lock stitch	
Maximum sewing speed	3,200 rpm	2,700 rpm
Pattern size (X x Y)	40 x 30 mm max.	6.4 x 6.4 mm max.
Dimensions of buttons that can be sewn		Outer diameter of button 8 - 30 mm (Use the optional button clamp B for diameters of 20 mm or greater.)
Feed mechanism	Y-θ intermittent feed mechanism (pulse-motor driven mechanism)	
Stitch length	0.05 - 12.7 mm	
Number of stitches	Variable (Refer to "Program List" for details on the number of stitches for sewing patterns that are already preset.)	
Maximum stitch number	210,000 stitches (including 200,000 stitches which can be added)	
Work clamp lifter	Pulse-motor driven mechanism	
Work clamp height	17 mm max.	13 mm max.
Rotary hook	Shuttle hook (shuttle hook 2, optional)	Shuttle hook
Wiper device	Standard equipment	
Thread trimmer device	Standard equipment	
Thread nipper device	Standard equipment	
Data storage method	Flash memory (Any sewing pattern can be added using CF card)	
Number of user programs	50	
Number of cycle programs	9	
Number of stored data	89 sewing patterns are set already	49 sewing patterns are set already
	(Up to 200 patterns can be added. Total number of stitches of stored data which can be added is within 200,000.)	
Motor	AC servo motor 550 W	
Weights	Machine head: approx. 56 kg, Operation panel: approx. 0.6 kg Control box: 14.2 - 16.2 kg (depending on destination)	
Power source	Single-phase 100V / 220V, 3-phase 200V / 220V / 380V / 400V	400VA

2-2. Program list

The programs shown below have been preset into the sewing machine and can be selected according to specifications. (Any program is available as long as the sewing pattern is within the work clamp and feed plate in size.) Use the work clamp and feed plate that match the respective sewing pattern selected. The sewing size is the length when the enlargement/reduction ratio is 100%.

For ordinary materials (-01)									
No.	Sewing pattern	No. of stitches	Tacking size (mm)		No.	Sewing pattern	No. of stitches	Tacking size (mm)	
			Length	Width				Length	Width
1		42	16	2	65		43	16	2
4		31	16	2	66		32	16	2
5		29	10	2	67		30	10	2
8		21	7	2	68		22	7	2
13		35	10	2	69		36	10	2
15		42	10	2	70		43	10	2
20		28	7	2	71		29	7	2
21		35	7	2	72		36	7	2
64		30	16	2	89		90	24	3

For denim (-02)									
No.	Sewing pattern	No. of stitches	Tacking size (mm)		No.	Sewing pattern	No. of stitches	Tacking size (mm)	
			Length	Width				Length	Width
2		42	20	3	18		56	24	3
3		35	20	3	19		64	24	3
6		30	16	3	62		42	20	3
14		35	16	3	63		35	20	3
16		43	16	3	78		43	20	3
17		42	24	3	79		36	20	3

For denim (-02)									
No.	Sewing pattern	No. of stitches	Tacking size (mm)		No.	Sewing pattern	No. of stitches	Tacking size (mm)	
			Length	Width				Length	Width
80		31	16	3	83		43	24	3
81		36	16	3	84		57	24	3
82		44	16	3	85		65	24	3

For foundation garments (-07)									
No.	Sewing pattern	No. of stitches	Tacking size (mm)		No.	Sewing pattern	No. of stitches	Tacking size (mm)	
			Length	Width				Length	Width
7		28	8	2	73		29	8	2
9		21	7	2	74		22	7	2
22		14	7	2	75		15	7	2
31*		28	8	2	76*		29	8	2
32*		22	8	2	77*		23	8	2
33*		15	8	2					

* The sewing start and sewing end are in the middle of the pattern.

Straight bar tacking					Vertical zigzag stitching				
No.	Sewing pattern	No. of stitches	Tacking size (mm)		No.	Sewing pattern	No. of stitches	Tacking size (mm)	
			Length	Width				Length	Width
10		21	10	0.3	44		46	9	15
11		28	10	0.3					
12		28	20	0.3					
23		35	25	0.3	45		70	9	25
24		42	25	0.3					
25		45	25	0.3					

Vertical bar tacking					Vertical straight bar tacking				
No.	Sewing pattern	No. of stitches	Tacking size (mm)		No.	Sewing pattern	No. of stitches	Tacking size (mm)	
			Length	Width				Length	Width
26		28	3	10	28		19	0.3	10
27		35	3	10	29		21	0.3	10
40		32	3	16	30		28	0.3	10
41		36	3	16	46		27	0.3	20
42		44	3	20	47		44	0.3	25
43		68	3	24					

Crescent bar tacking									
No.	Sewing pattern	No. of stitches	Tacking size (mm)		No.	Sewing pattern	No. of stitches	Tacking size (mm)	
			Length	Width				Length	Width
34		35	12	7	37		57	7	12
35		58	12	7	38		53	7	10
36		57	7	12	39		53	7	10

Crossed stitching					Crossed tacking				
No.	Sewing pattern	No. of stitches	Tacking size (mm)		No.	Sewing pattern	No. of stitches	Tacking size (mm)	
			Length	Width				Length	Width
48		70	10	10	50		84	16	16
49		93	9.6	9.6	51		105	30	26

L-pattern tacking									
No.	Sewing pattern	No. of stitches	Tacking size (mm)		No.	Sewing pattern	No. of stitches	Tacking size (mm)	
			Length	Width				Length	Width
52		60	11.3	11.2	53		60	11.3	11.2
54		78	15.3	15.2	55		78	15.3	15.2

Circular stitching									
No.	Sewing pattern	No. of stitches	Tacking size (mm)		No.	Sewing pattern	No. of stitches	Tacking size (mm)	
			Length	Width				Length	Width
56		106	9	9	59		104	10	10
57		116	9	9	60		114	10	10
58		127	9	9	61		124	10	10

For eyelet buttonhole				
No.	Sewing pattern	No. of stitches	Tacking size (mm)	
			Length	Width
86		21	6	2
87		28	6	2
88		35	6	2

If you want to sew a pattern other than standard patterns, you can create your original pattern using the PS-3000. Consult with your local Supreme sales Office for details.

Note when creating additional data (program nos. 200 - 999)

When sewing data with a small number of stitches (15 stitches or less) is sewn repeatedly (short cycle operation), the upper shaft motor may overheat and the "E150" error code may be generated.

2-3. Program list

The programs shown below have been preset into the sewing machine. Any program is available as long as the needle drops down in the hole of the button. When sewing programs that do not have crossover stitches, the thread is trimmed after sewing of one side is completed, and then the other side is sewn.

No.	No. of button holes	Sewing pattern	No. of threads	No. of crossover stitches	No. of stitches	Sewing size (mm)	
						X	Y
1	2		6	—	12	3.4	0
2			8	—	14		
3			10	—	16		
4			12	—	18		
5 *1			16	—	22		
6 *1			20	—	26		
7 *2	2		6	—	12	0	3.4
23 *2			10	—	16		
8 *2			12	—	18		
9 *2	3		5-5-5	—	21	2.6	2.4
24 *2			7-7-7	—	27		
25 *2			5-5-5	—	21		
26 *2			7-7-7	—	27		
10	4		6-6	1	19	3.4	3.4
11			8-8	1	23		
12			8-8	3	25		
13			10-10	1	27		
27			12-12	1	31		

*1 Check that the button hole diameter is 2 mm or greater before using the programs.

*2 Do not use the button lifter spring.

2. SPECIFICATIONS

No.	No. of button holes	Sewing pattern	No. of threads	No. of crossover stitches	No. of stitches	Sewing size (mm)		
						X	Y	
14	*3		6-6	0	24	3.4	3.4	
36	*4		6-6	0	24			
28	*3		8-8	0	28			
37	*4		8-8	0	28			
15	*3		10-10	0	32			
38	*4		10-10	0	32			
29	*3		12-12	0	36			
39	*4		12-12	0	36			
16				6-5	1			18
17				8-7	1			22
30	4	10-9		1	26			
18			6-6	1	19			
19			8-8	1	23			
31			10-10	1	27			
45			12-12	1	31			
20	*3		6-6	0	24			
40	*4	6-6	0	24				
32	*3	8-8	0	28				
41	*4	8-8	0	28				
33	*3	10-10	0	32				
42	*4	10-10	0	32				

*3 When sewing of one side is completed, the button clamp rises and the thread is trimmed. To finish sewing, press the foot switch until sewing of the other side starts, or press the foot switch again after sewing of the other side is completed.

*4 When sewing of one side is completed, the thread will be trimmed without the button clamp rising, and then the other side will be sewn.

2. SPECIFICATIONS

No.	No. of button holes	Sewing pattern	No. of threads	No. of crossover stitches	No. of stitches	Sewing size (mm)	
						X	Y
21	*2		6-6	1	19	2.4	3.4
34	*2		10-10	1	27		
22	*2 *3		6-6	0	24		
43	*2 *4		6-6	0	24		
35	*2 *3		10-10	0	32		
44	*2 *4		10-10	0	32		
46			6-6	1	19	3.4	3.4
47			8-8	1	23		
48			10-10	1	27		
49			12-12	1	31		

*2 Do not use the button lifter spring.

*3 When sewing of one side is completed, the button clamp rises and the thread is trimmed. To finish sewing, press the foot switch until sewing of the other side starts, or press the foot switch again after sewing of the other side is completed.

*4 When sewing of one side is completed, the thread will be trimmed without the button clamp rising, and then the other side will be sewn.

Note when creating additional data (program nos. 200 - 999)

When sewing data with a small number of stitches (15 stitches or less) is sewn repeatedly (short cycle operation), the upper shaft motor may overheat and the "E150" error code may be generated.

3. INSTALLATION

CAUTION

- ⊘ Machine installation should only be carried out by a qualified technician.
- ⚠ Contact your Brother dealer or a qualified electrician for any electrical work that may need to be done.
- ⚠ The sewing machine head weighs approximately 56 kg. The installation should be carried out by two or more people.
- ⊘ Do not connect the power cord until installation is complete, otherwise the machine may operate if the foot switch is depressed by mistake, which could result in injury.
- ⚠ Hold the machine head with both hands when tilting it back or returning it to its original position. Furthermore, after tilting back the machine head, do not push the face plate side or the pulley side from above, as this could cause the machine head to topple over, which may result in personal injury or damage to the machine.
- ⚠ All cords should be secured at least 25 mm away from any moving parts. Furthermore, do not excessively bend the cable or secure it too firmly staples, otherwise there is the danger that fire or electric shocks could occur.
- ⚠ Be sure to connect the ground. If the ground connection is not secure, you run the risk of receiving a serious electric shock, and problems with correct operation may also occur.
- ⚠ Install the safety covers to the machine head and motor.

3-1. Table processing diagram

- The thickness of the table should be at least 40 mm, and it should be strong enough to bear the weight and vibration of the sewing machine.
- If the distance A between the insides of the legs is less than 740 mm, move the control box installation position to the left (B = 254 mm).
- Check that the control box is at least 10 mm away from the leg. If the control box and the leg are too close together, it may result in incorrect sewing machine operation.

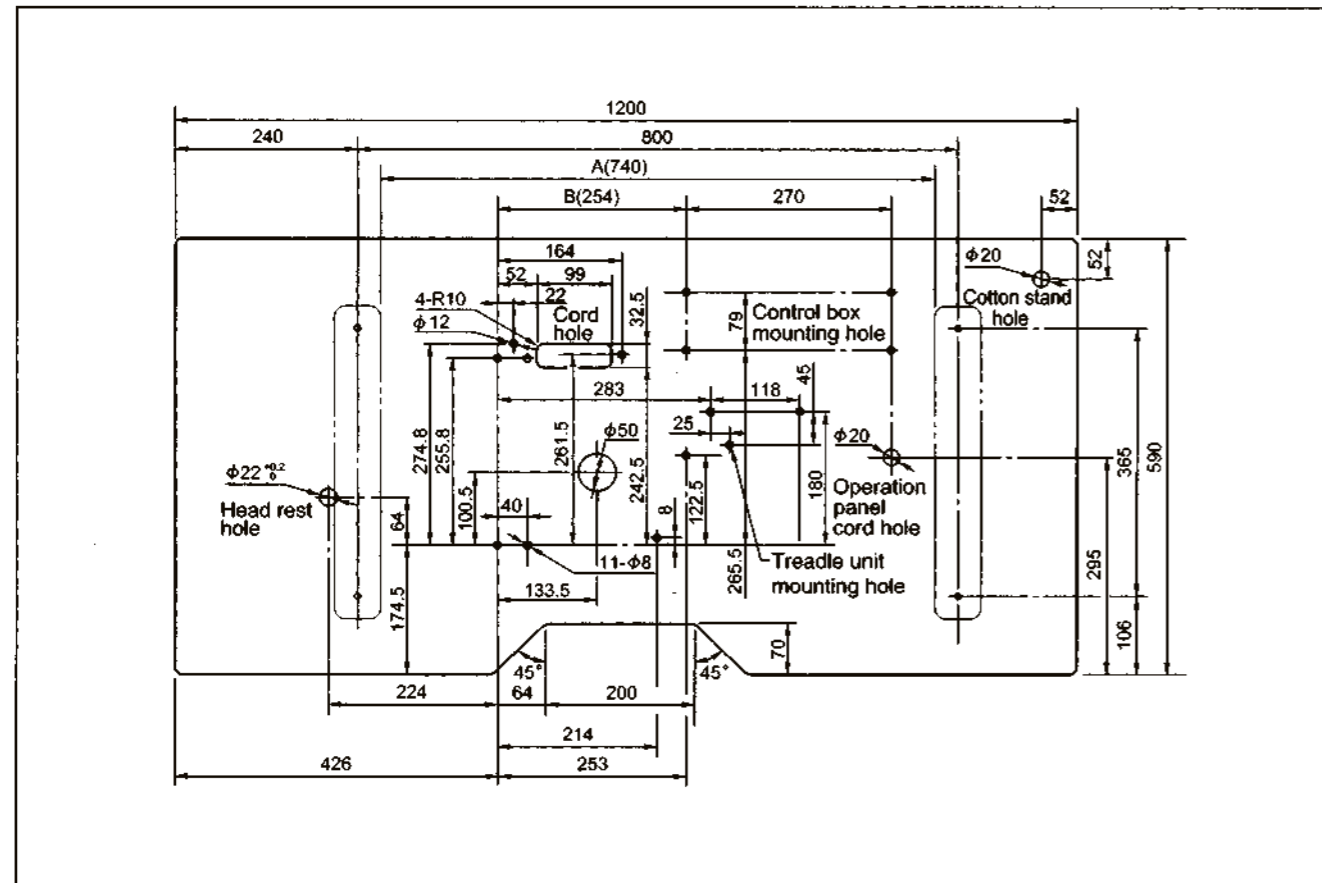

3-2. Installing the control box

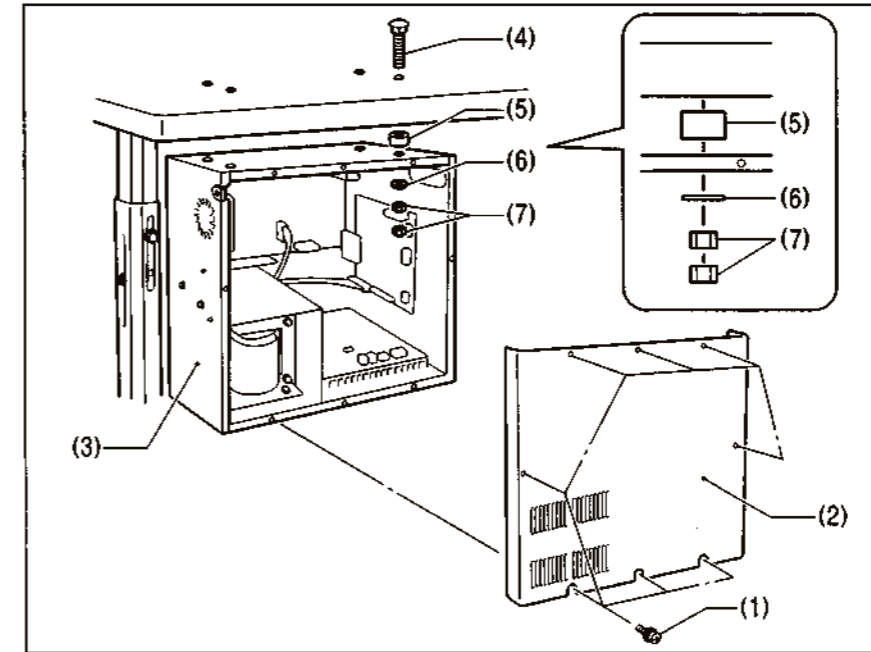

Remove the eight screws (1), and then remove the control box cover (2).

- (3) Control box
- (4) Bolts [4 pcs]
- (5) Spacers [4 pcs]
- (6) Plain washers [4 pcs]
- (7) Nuts [8 pcs]

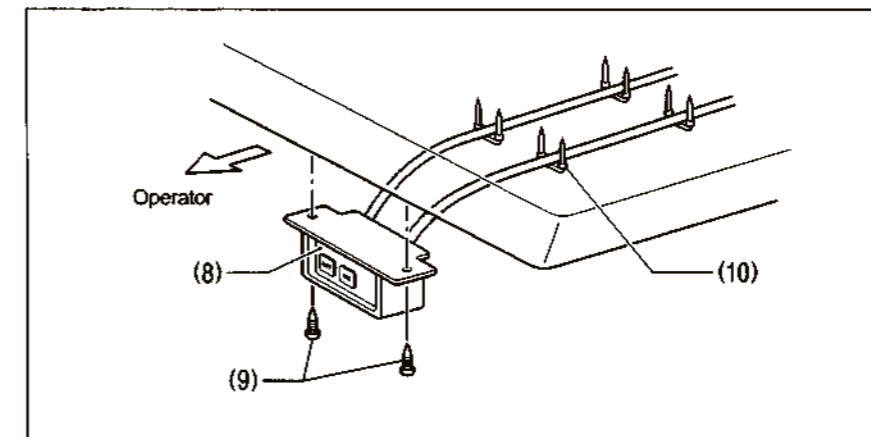

- (8) Power switch
- (9) Wood screws [2 pcs]
- (10) Staples [4 pcs]

3-3. Installing the oil pan

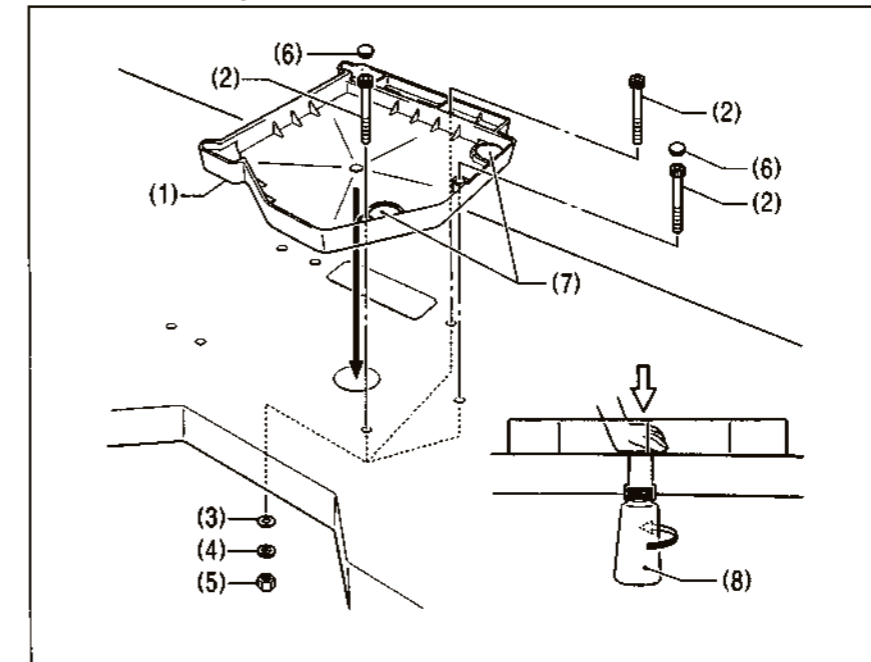

- (1) Oil pan
- (2) Bolts [3 pcs]
- (3) Plain washers [3 pcs]
- (4) Spring washers [3 pcs]
- (5) Nuts [3 pcs]
- (6) Rubber caps [2 pcs]
- (7) Rubber cushion [2 pcs]
- (8) Oiler

3-4. Installing the machine head

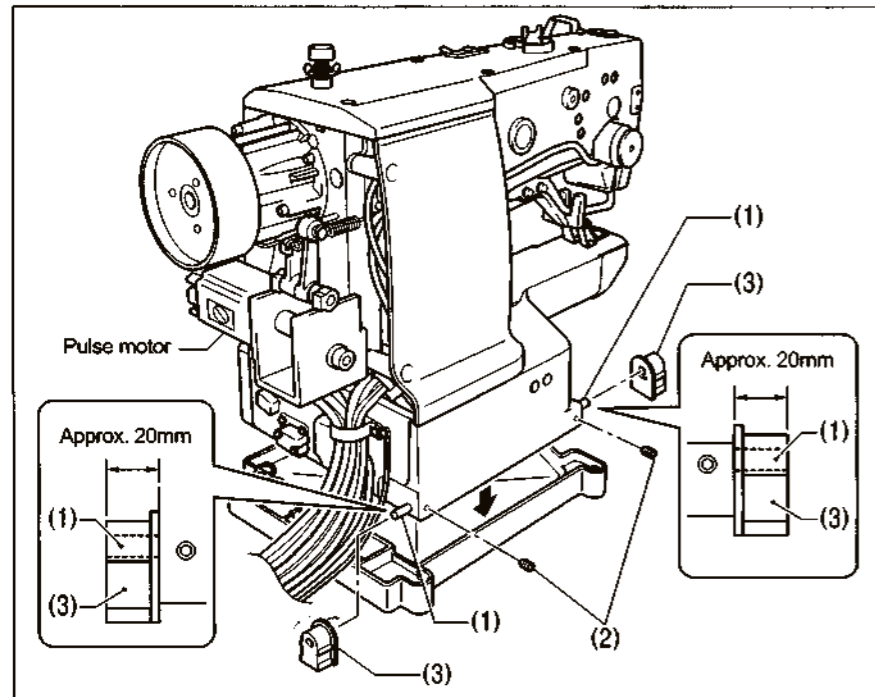

- (1) Pins [2 pcs]
- (2) Set screws [2 pcs]
- (3) Rubber cushion assembly [2 pcs]

Place the machine head gently on top of the oil pan and the rubber cushions.

Note:

- Be careful not to clamp any cords between the machine head and the oil pan.
- When holding the machine head, do not hold it by the pulse motor, otherwise it may damage the pulse motor.

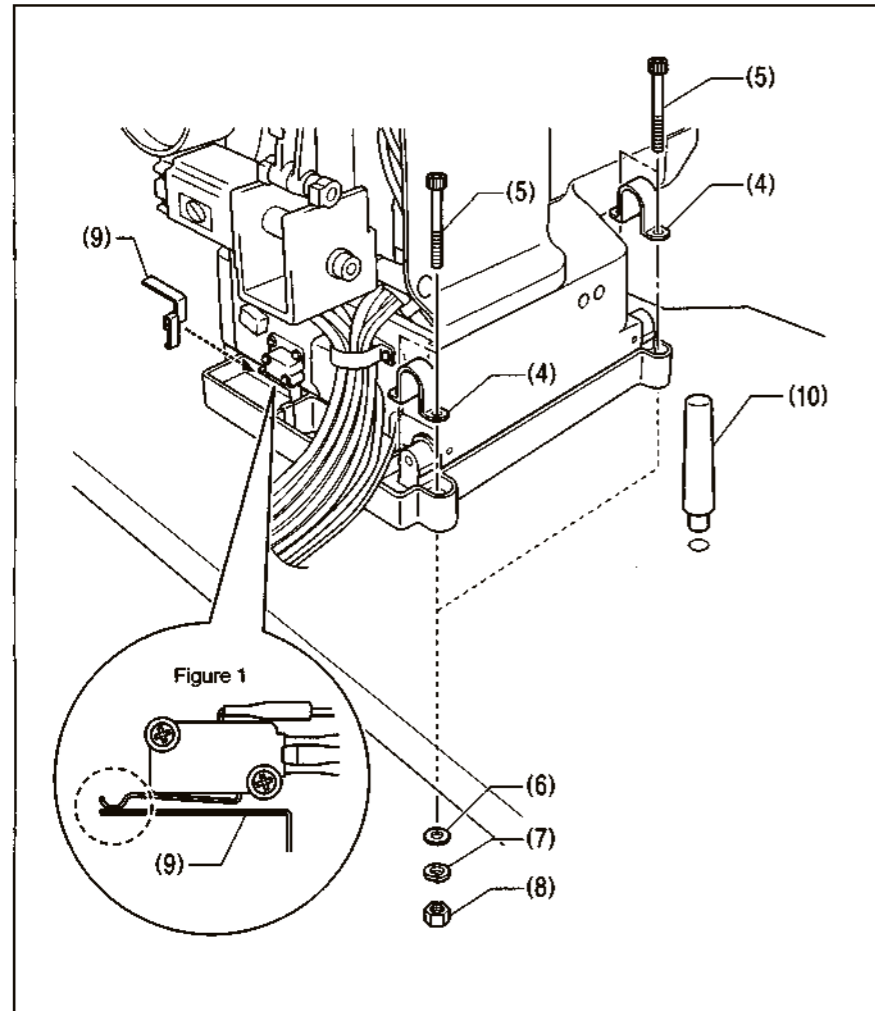

- (4) Hinge holders [2 pcs]
- (5) Bolts [4 pcs]
- (6) Plain washers [4 pcs]
- (7) Spring washers [4 pcs]
- (8) Nuts [4 pcs]
- (9) Head spring
- (10) Head rest

Note:

- Check that the machine head switch is turned on as shown in Figure 1.
- Tap the head rest (10) securely into the table hole.

3-5. Installing the operation panel

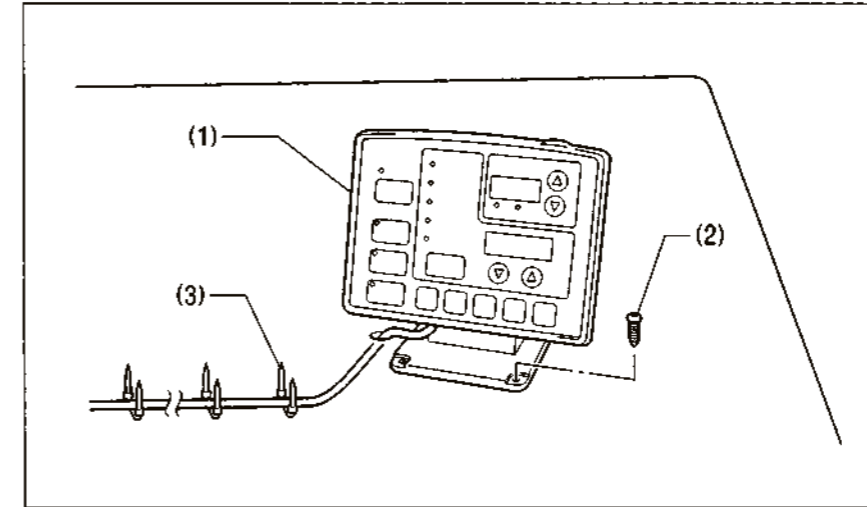

- (1) Operation panel
- (2) Wood screws [4 pcs]

* Pass the panel cord through the hole in the table, and then insert it into the control box through the hole in the side of the control box.

- (3) Staples [3 pcs]

3-6. Installing the treadle unit

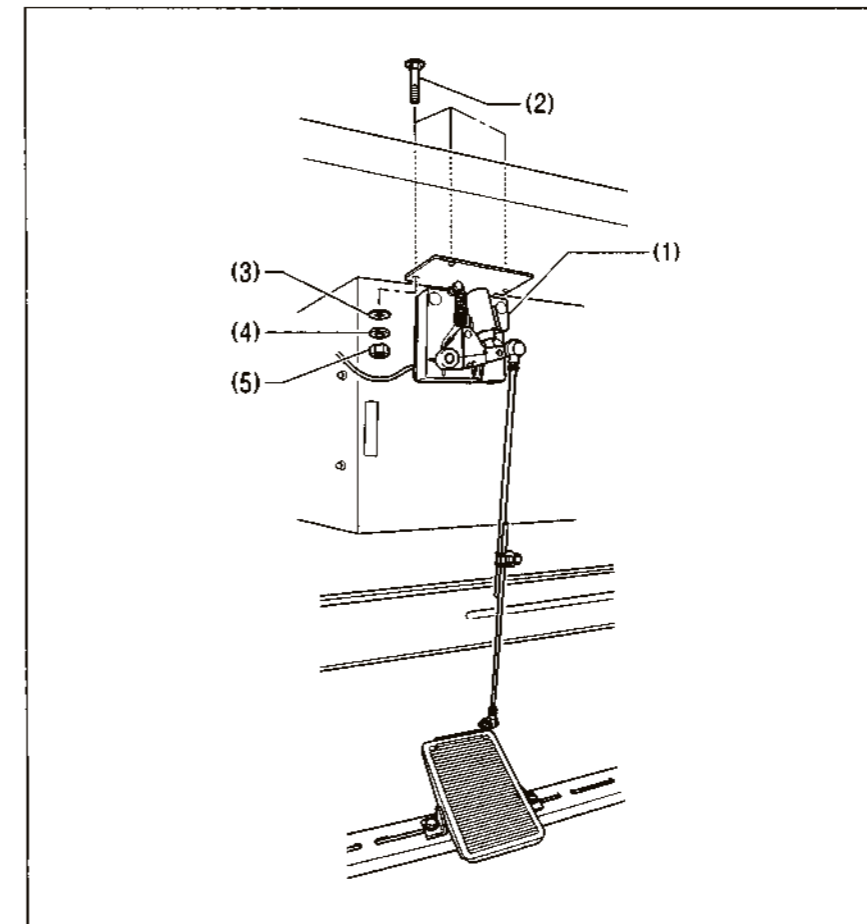

- (1) Treadle unit
- (2) Bolts [3 pcs]
- (3) Plain washers [3 pcs]
- (4) Spring washers [3 pcs]
- (5) Nuts [3 pcs]

* Use a commercially-available foot switch and connecting rod.

3-7. Installing the cotton stand

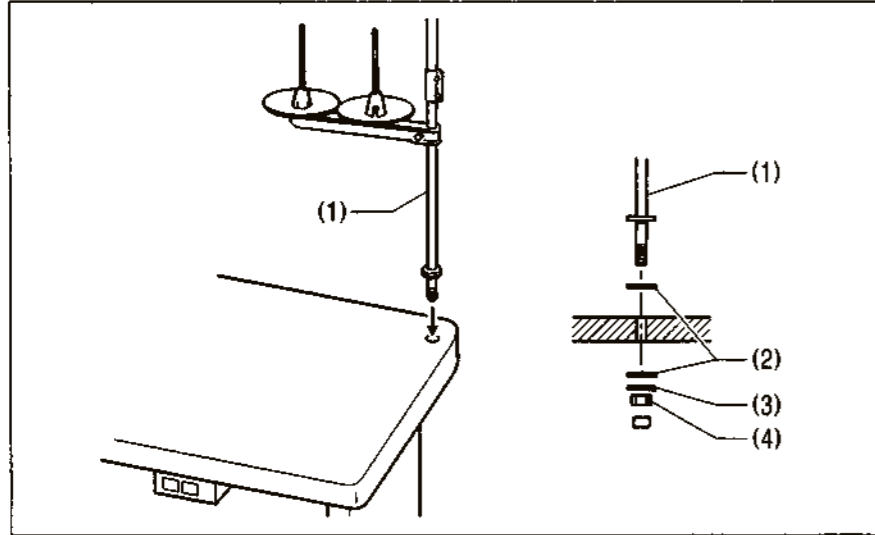

(1) Cotton stand

Note:

Securely tighten the nut (4) so that the two rubber cushions (2) and the washer (3) are securely clamped and so that the cotton stand (1) does not move.

3-8. Installing the button tray (CSM-438D)

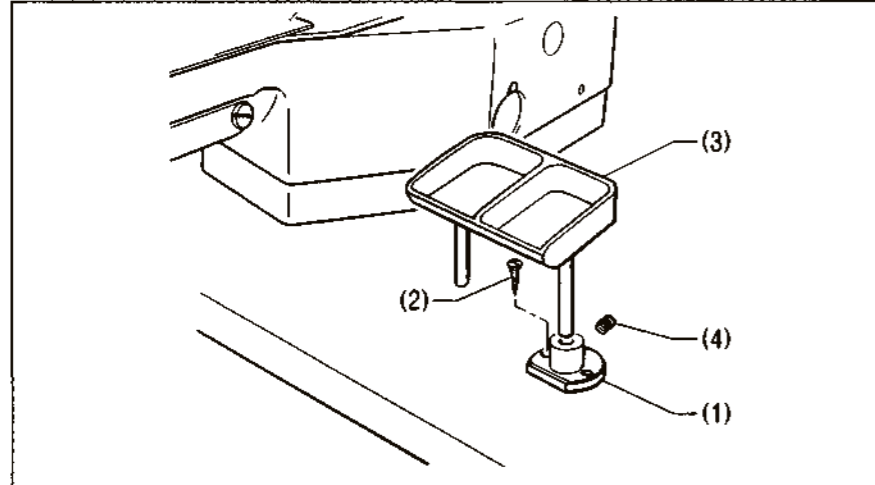

Install the button tray at a place convenient for operation.

- (1) Button tray holder
- (2) Wood screws [2 pcs]
- (3) Button tray
- (4) Set screw

3-9. Installing the eye guard

CAUTION

Attach all safety devices before using the sewing machine.
If the machine is used without these devices attached, injury may result.

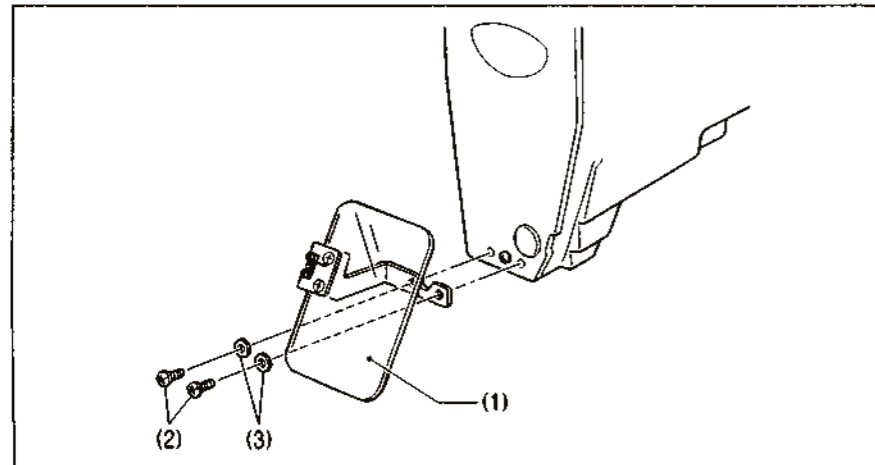

- (1) Eye guard assembly
- (2) Screws [2 pcs]
- (3) Plain washers [2 pcs]

3-10. Connecting the cords

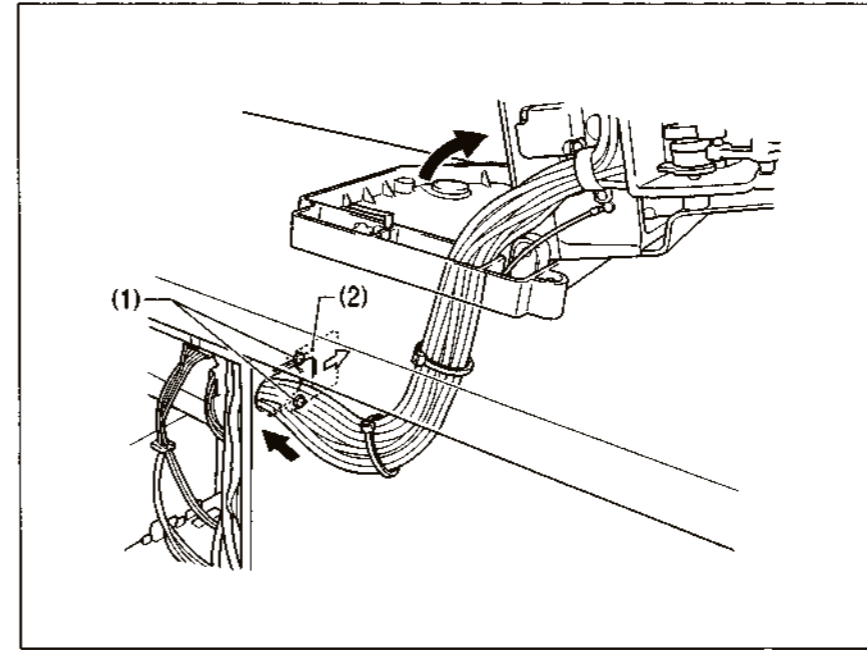

1. Gently tilt back the machine head.
2. Pass the cord bundle through the hole in the work table.
3. Loosen the two screws (1), and then open the cord presser plate (2) in the direction of the white arrow and pass the cord bundle through the opening.
4. Securely connect the connectors as indicated in the table below.

Note:

- Check that the connector is facing the correct way, and then insert it firmly until it locks into place.
- Secure the cables with cable ties and cord clamps, while being careful not to pull on the connector.

< Main P. C. board >

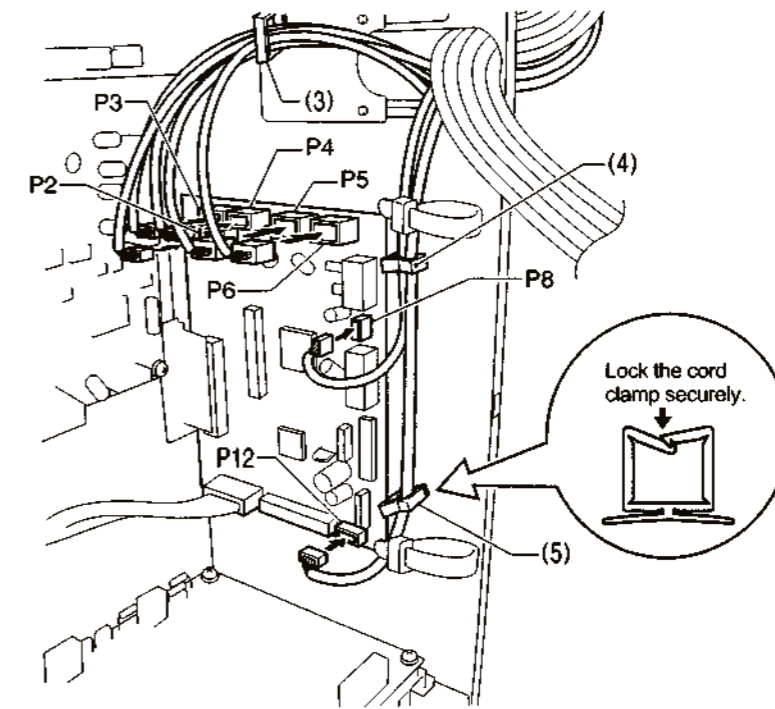

Connectors	Connection location on main P. C. board	Cord clamps
X pulse motor encoder [5-pin] White	P2 (X-ENC)	(3)
Y pulse motor encoder [5-pin] Blue	P3 (Y-ENC)	(3)
Work clamp encoder [5-pin] Black	P4 (P-ENC)	(3)
Foot switch [10-pin]	P5 (FOOT)	(3)
Operation panel [8-pin]	P6 (PANEL)	(3)
Machine head switch [3-pin]	P8 (HEAD-SW)	(4)
Thread clamp sensor [6-pin]	P12 (TPK-SEN)	(4), (5)

< Power supply motor P. C. board >

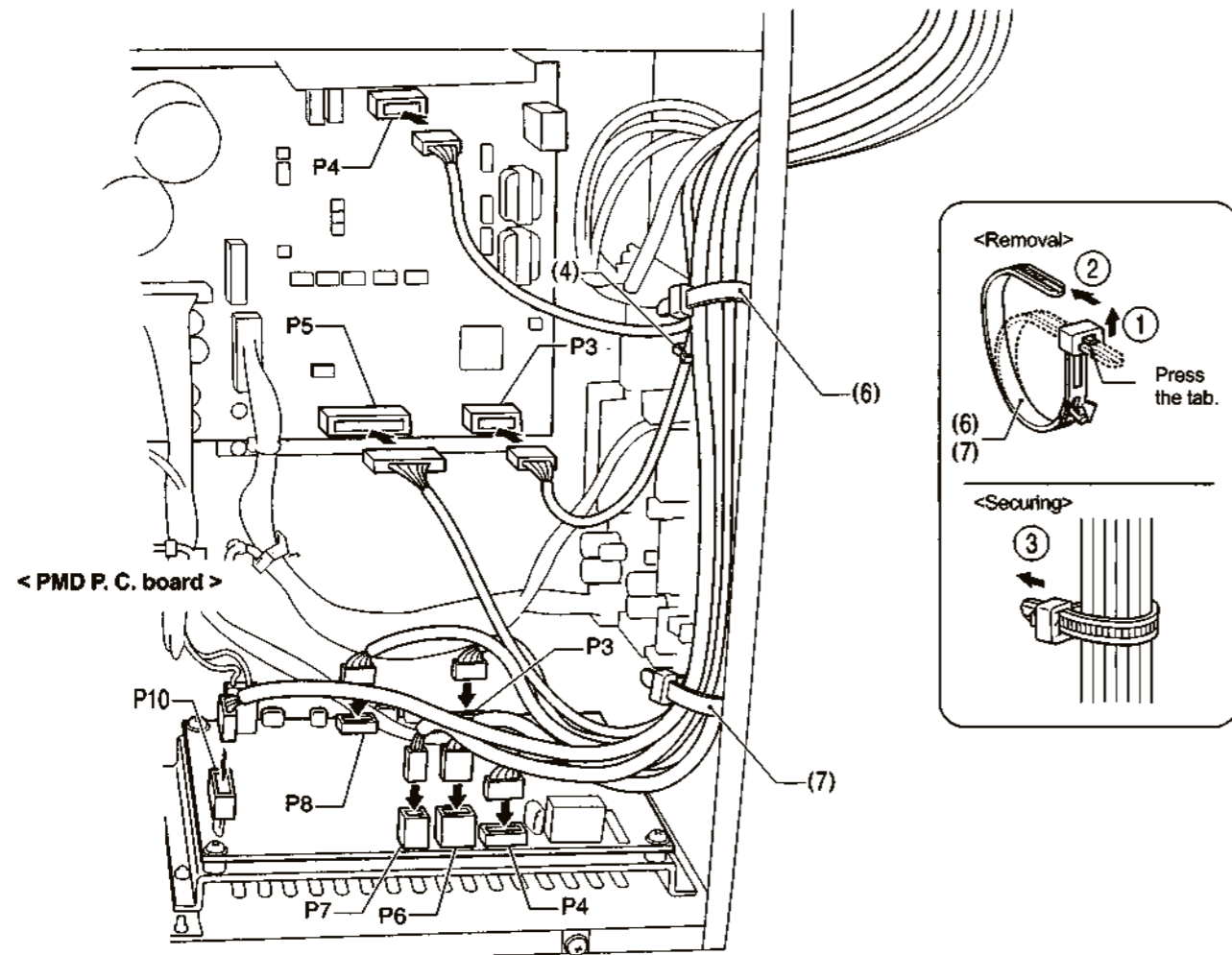

< PMD P. C. board >

Connectors	Connection location on power supply motor P. C. board	Cord clamps / Cable ties
Machine head memory [7-pin]	P3 (HEAD-M)	(4)
Upper shaft motor [3-pin]	P4 (UVW)	(6)
Synchronizer [14-pin]	P5 (SYNC)	(6), (7)
Connectors	Connection location on PMD P. C. board	Cable ties
Work clamp pulse motor [4-pin] Black	P3 (PPM)	(6), (7)
Thread clamp pulse motor [6-pin]	P4 (BT-PICK)	(6), (7)
Thread trimmer solenoid [6-pin]	P6 (SOL1)	(6), (7)
Tension release solenoid [4-pin]	P7 (SOL2)	(6), (7)
Y pulse motor [4-pin] Blue	P8 (YPM)	(6), (7)
X pulse motor [4-pin] White	P10 (XPM)	(6), (7)

Note: Route the X, Y and work clamp pulse motor harnesses so that they do not touch the PMD P.C. board.

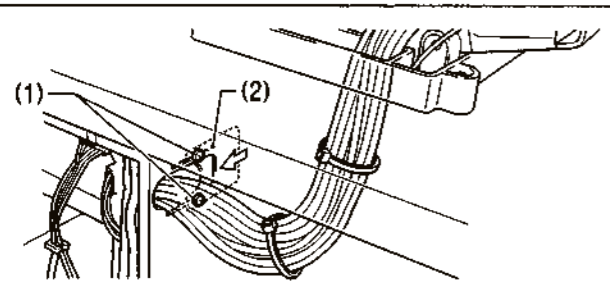

5. Close the cord presser plate (2) in the direction of the white arrow, and secure it by tightening the two screws (1).
6. Check that the cords do not get pulled, and then gently return the machine head to its original position.

3-11. Connecting the ground wire

CAUTION

Be sure to connect the ground. If the ground connection is not secure, you run the risk of receiving a serious electric shock, and problems with correct operation may also occur.

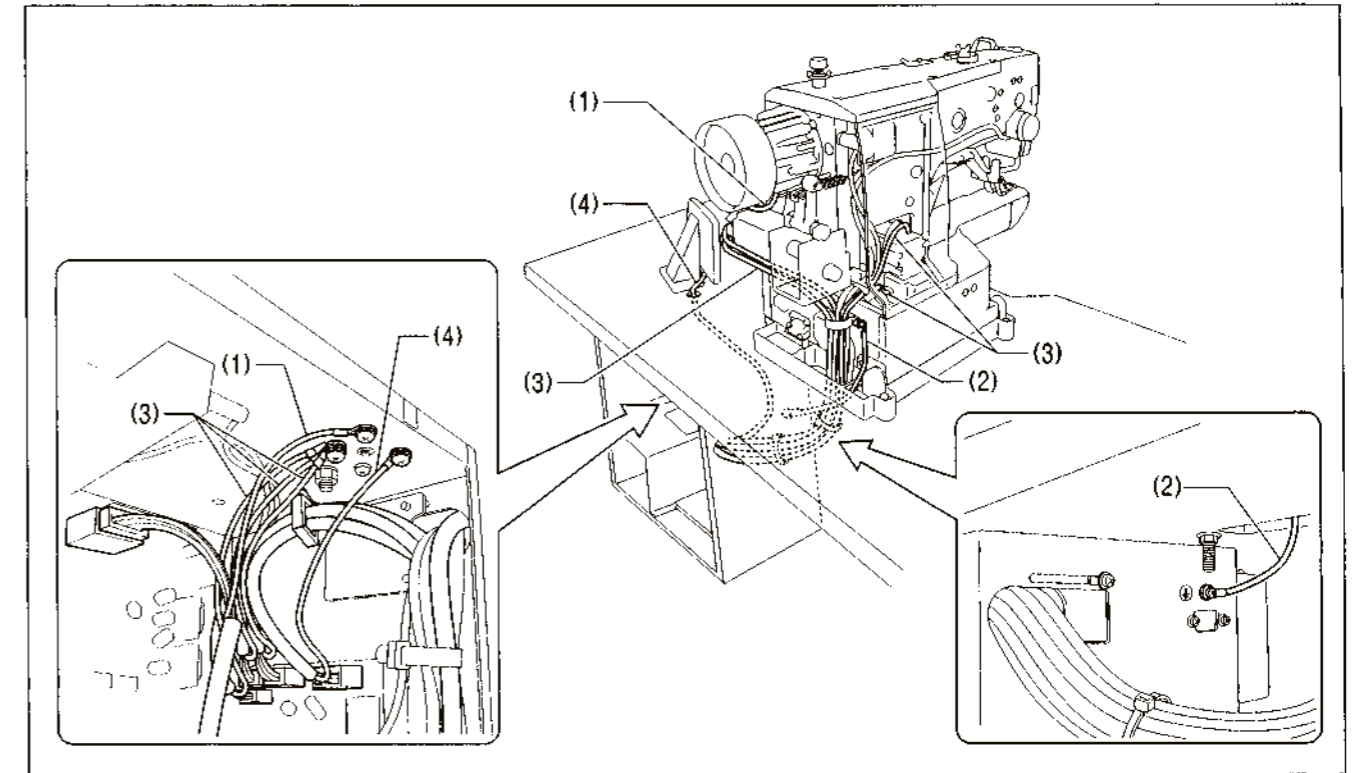

- (1) Ground wire from upper shaft motor harness
- (2) Ground wire from the machine head
- (3) Ground wires from X, Y and work clamp encoder harnesses (3 wires)
- (4) Ground wire from operation panel harness

• Tighten the control box cover with the eight screws. Check that the cords are not clamped by the cover at this time.
 Note: Make sure that the ground connections are secure in order to ensure safety.

3-12. Installing the back cover

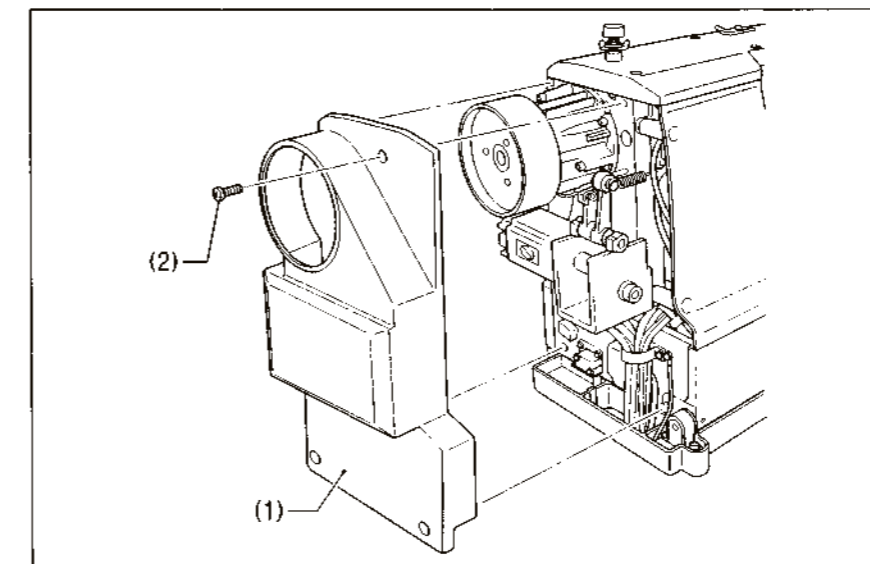



- (1) Back cover
- (2) Screws [4 pcs]

Note: Be careful not to clamp the cords when installing the back cover (1).

3-13. Lubrication

CAUTION

-  Do not connect the power cord until lubrication has been completed, otherwise the machine may operate if the foot switch is depressed by mistake, which could result in injury.
-  Be sure to wear protective goggles and gloves when handling the lubricating oil and grease, so that they do not get into your eyes or onto your skin, otherwise inflammation can result. Furthermore, do not drink the oil or eat the grease under any circumstances, as they can cause vomiting and diarrhoea. Keep the oil out of the reach of children.

The sewing machine should always be lubricated and the oil supply replenished before it is used for the first time, and also after long periods of non-use.

Use only the lubricating oil <Nisseki Mitsubishi Sewing Lube 10N; VG10> specified by Supreme.

* If this type of lubricating oil is difficult to obtain, the recommended oil to use is <Exxon Mobil EssoTex SM10; VG10>

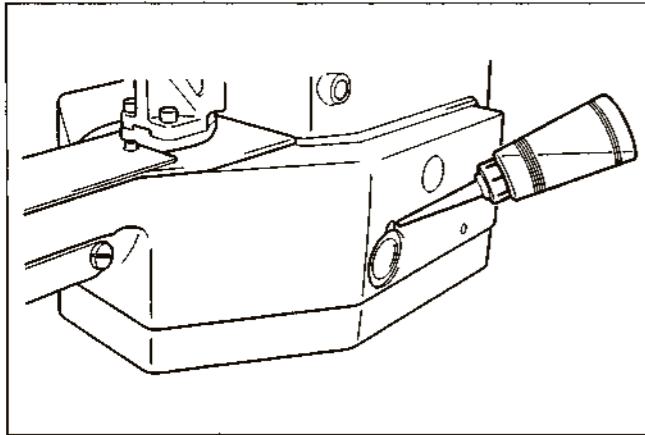

1. Fill the oil tank with oil.

Note:

Fill the machine with oil when the oil level is down to about one-third full in the oil sight glass. If the oil drops below this level, there is the danger that the machine may seize during operation.

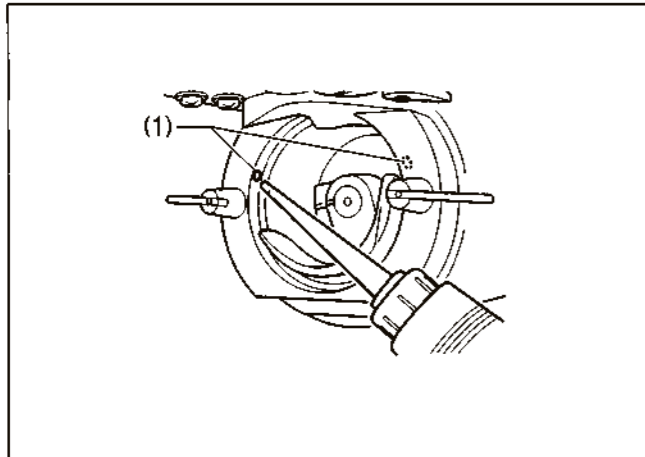

2. Pour oil in through the two holes (1) of the shuttle race base assembly so that the felt is lightly moistened.

Note:

If there is no more oil on the felt of the shuttle race base assembly, problems with sewing may result.

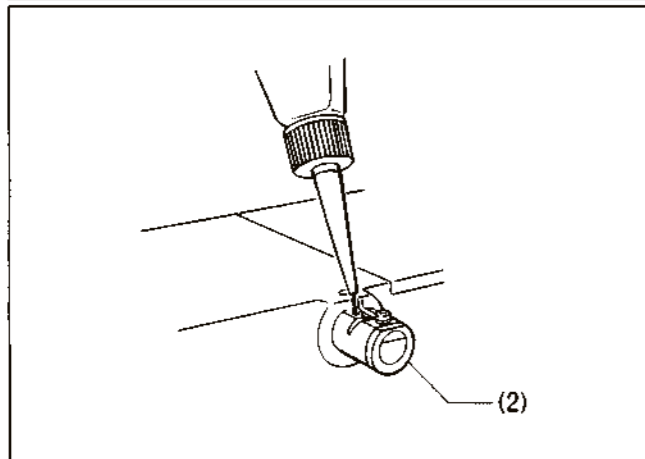

3. If using the liquid cooling tank (2), fill it with silicon oil (100 mm²/s).

3-14. Starting up

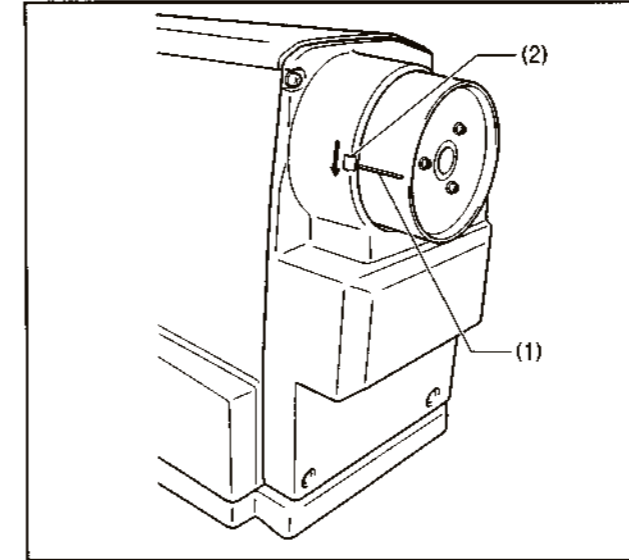

Before starting home position detection, check that the needle bar is at its highest position.

Turn the machine pulley so that the index mark (1) on the pulley is inside the mark (2) on the back cover.

Note:

If the machine is started while the index mark (1) is not inside the mark (2), error code "E110" will be displayed. (At this time, the error will be cleared if you turn the machine pulley to set the needle to the needle up stop position.)

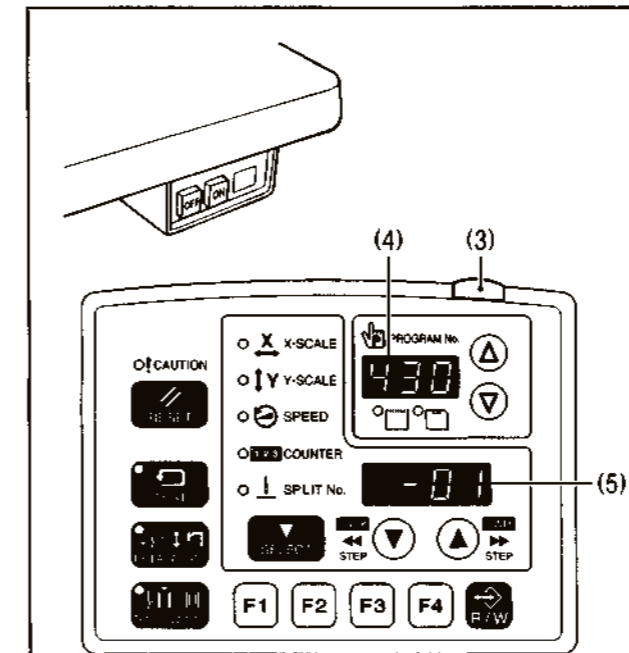

1. Turn on the power switch. The POWER indicator (3) will illuminate, and the model name will appear in the program No. display (4) and the specifications will appear in the menu display (5).

Specifications	
Ordinary materials	[- 01]
Denim	[- 02]
Foundation garments	[- 07]

After this, the program number will flash in the program No. display (4).

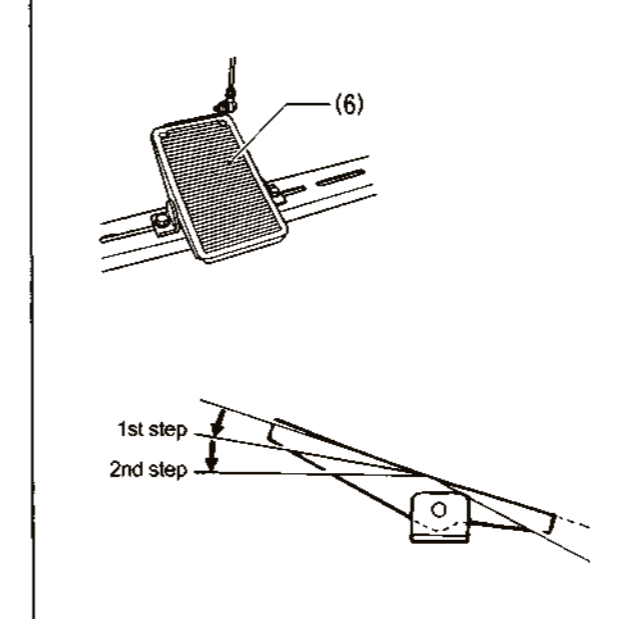

2. Depress the foot switch (6) to the 2nd step. The feed mechanism will move to the home position and the work clamp / button clamp will rise.

4. PREPARATION BEFORE SEWING

4-1. Installing the needle

CAUTION

Turn off the power switch before installing the needle, otherwise the machine may operate if the foot switch is depressed by mistake, which could result in injury.

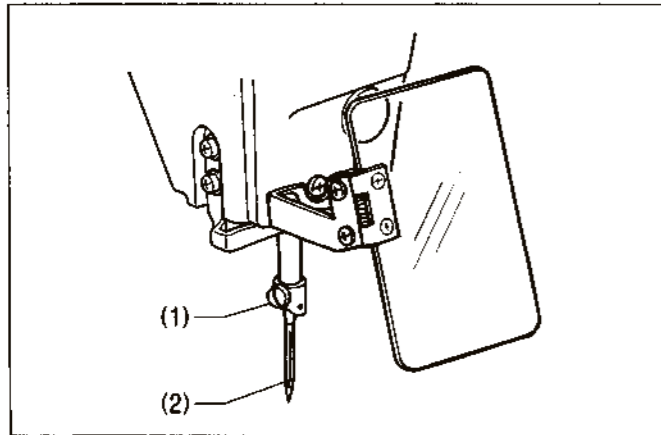

1. Loosen the set screw (1).
2. Insert the needle (2) in a straight line as far as it will go, making sure that the long groove on the needle is at the front, and then securely tighten the screw (1).

4-2. Threading the upper thread

Thread the upper thread correctly as shown in the illustration below.

* When using threading mode for threading, the tension discs (1) will open so that the thread can be threaded more easily. (Refer to following page.)

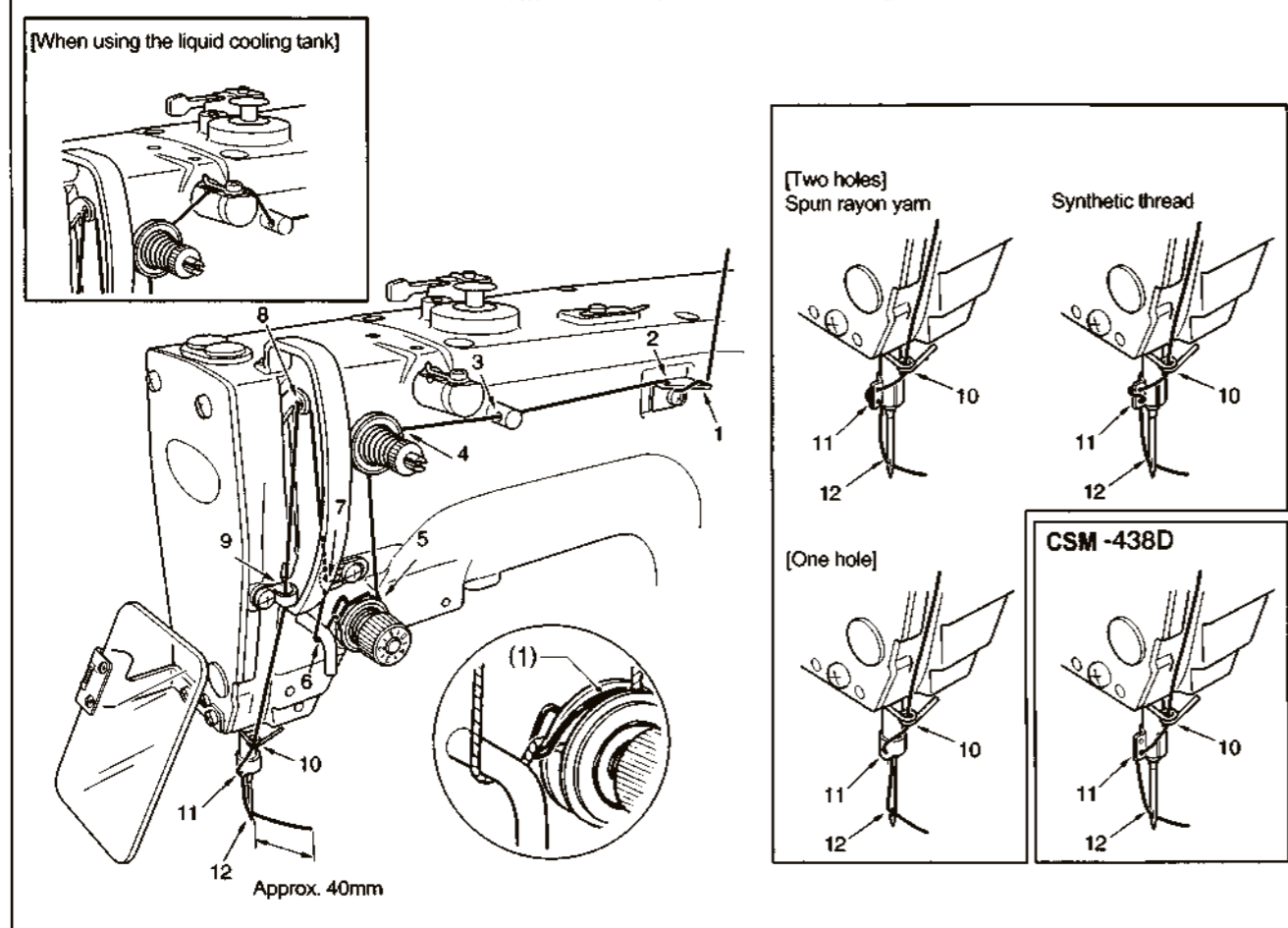

<Threading mode>

Threading mode is safe because the sewing machine will not start even when the foot switch is depressed.

1	<p>Turn on the power switch.</p>
2	<p>Press the THREAD/CLAMP key.</p> <p>All indicators switch off</p> <p>THREAD/CLAMP indicator lights Menu indicators switch off</p> <ul style="list-style-type: none"> • The work clamp /button clamp will lower. • The tension discs will open.
3	<p>Threading the thread.</p> <ul style="list-style-type: none"> • When 5 minutes have passed, the buzzer will sound and the tension discs will close.
4	<p>Ending threading mode</p> <p>Press the THREAD/CLAMP key.</p> <ul style="list-style-type: none"> • The work clamp/button clamp will return to where it was before threading mode was started. <p>THREAD/CLAMP indicator switches off</p>

4-3. Winding the lower thread

CAUTION

Do not touch any of the moving parts or press any objects against the machine while winding the lower thread, as this may result in personal injury or damage to the machine.

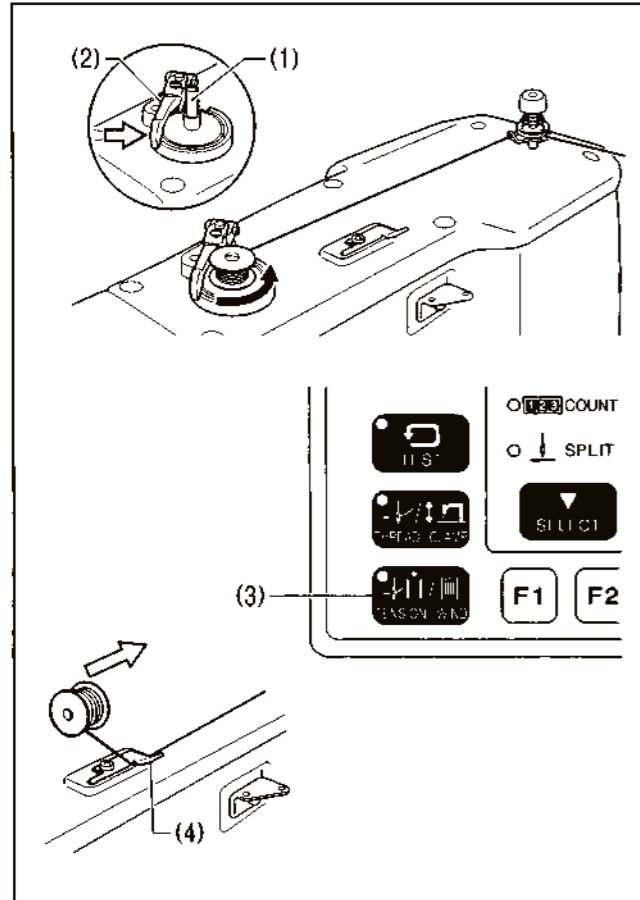

1. Place the bobbin onto the bobbin winder shaft (1).
2. Thread the thread as shown in the illustration, wind the thread around the bobbin several times, and then press the bobbin presser arm (2).
3. Turn on the power switch.
4. Depress the foot switch to the second step. The feed mechanism will move to the home position.
5. Check that the needle is not touching the work clamp, and then while pressing the TENSION WIND key (3), depress the foot switch to the second step.
6. Release the TENSION WIND key (3) after the machine starts operating, and keep depressing the foot switch until the lower thread stops being wound onto the bobbin. (If you release the foot switch before winding is complete, and then depress it again while pressing the TENSION/WIND key (3), winding will start again.)
7. Once winding of the set amount of lower thread (80 - 90% of the bobbin capacity) is completed, the bobbin presser arm (2) will return automatically.
8. Remove the bobbin, hook the thread onto the knife (4), and then pull the bobbin in the direction of the arrow to cut the thread.

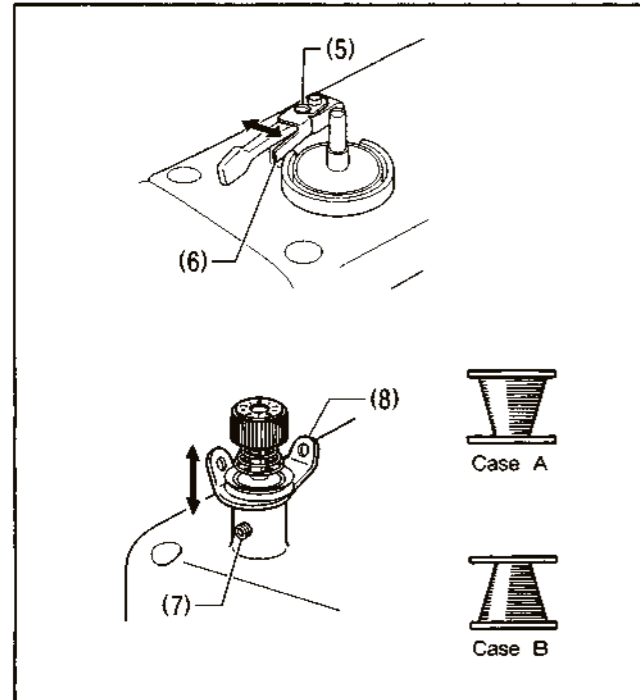

Adjusting the bobbin winding amount
Loosen the screw (5) and move the bobbin presser (6).

If the thread winds onto the bobbin unevenly
Loosen the set screw (7) and move the bobbin winder tension assembly (8) up and down to adjust.
* For case A, move the bobbin winder tension assembly (8) down, and for case B, move it upward.

4-4. Installing the bobbin case

CAUTION

Turn off the power switch before installing the bobbin case, otherwise the machine may operate if the foot switch is depressed by mistake, which could result in injury.

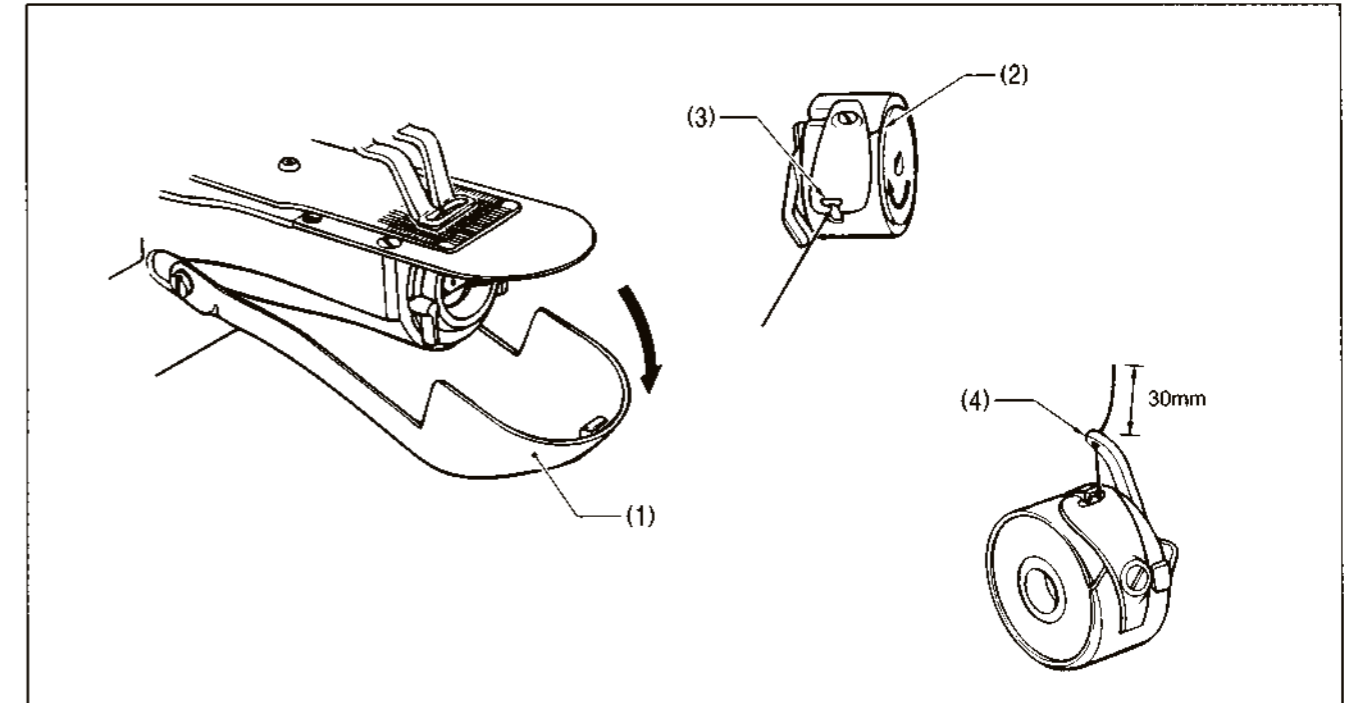

1. Pull the shuttle race cover (1) downward to open it.
2. While holding the bobbin so that the thread winds to the right, insert the bobbin into the bobbin case.
3. Pass the thread through the slot (2) and pull it out from the thread hole (3).
4. Check that the bobbin turns in the direction of the arrow when the thread is pulled.
5. Pass the thread through the lever thread hole (4), and then pull out approximately 30 mm of thread.
6. Hold the latch on the bobbin case and insert the bobbin case into the rotary hook.

4-5. Thread tension

4-5-1. Lower thread tension

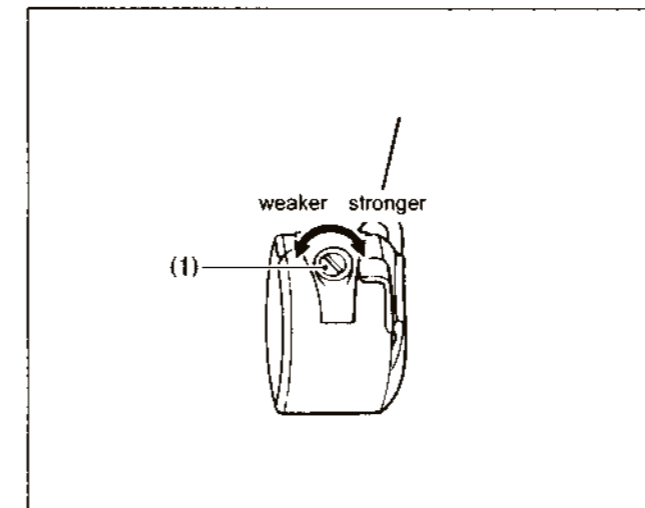

Adjust the thread tension to the weakest possible tension by turning the thread tension nut (1) until the bobbin case will not drop by its own weight while the thread end coming out of the bobbin case is held.

4-5-2. Upper thread tension

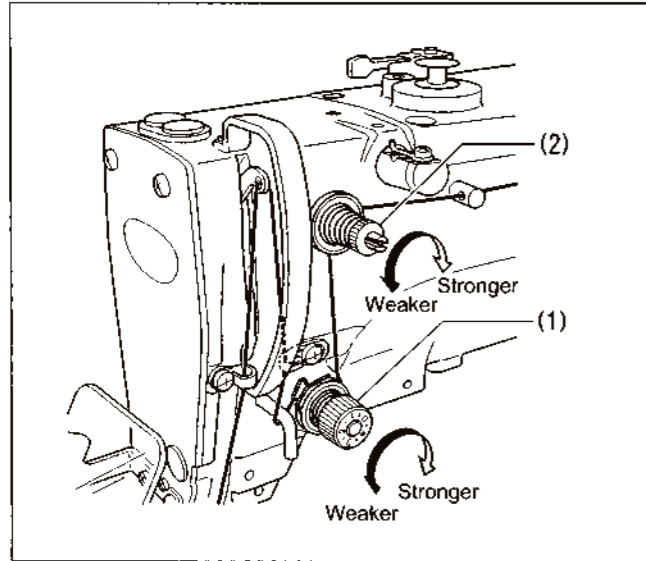

Turn the tension nut (1) (main tension) to adjust the tension as appropriate for the material being sewn. Furthermore, turn the tension nut (2) (sub-tension) to adjust the remaining length of upper thread to 35 - 40 mm, when the thread take-up lever is not used.

[Reference thread tension]

Use	Reference thread tension			
	Ordinary materials (-01)	Foundation garments (-07)	Denim (-02)	
Upper thread	#50 or equivalent	#60 or equivalent	#30 or equivalent	#60 or equivalent
Lower thread	#60 or equivalent	#80 or equivalent	#50 or equivalent	#60 or equivalent
Upper thread tension (N)	0.8 - 1.2		1.6 - 2.0	1.0 - 1.8
Lower thread tension (N)	0.2 - 0.3			0.2 - 0.4
Pre-tension (N)	0.05 - 0.3			0.1 - 0.4
Needle	DP x 5 #14	DP x 5 #9	DP x 17NY #19	DP x 17NY #12

[Guide to maximum sewing speed]

Use	Max. sewing speed (rpm)	
	Standard hook	Large hook
8 layers of denim	3,200	2,500
12 layers of denim	2,700	
Ordinary materials	2,700	2,500
Foundation garments	2,500	

Note:
The thread may break due to heat under some sewing conditions. If this happens, reduce the sewing speed, or use the liquid cooling tank.

4-6. Thread nipper device

This is used to stop the thread from pulling out at the sewing start, and at times when skipped stitches might easily occur. The thread nipper device operates when memory switch no. 500 is set to "ON". However, some limitations apply. Refer to "6-3. List of memory switches" for details.
* The default setting for this memory switch is "OFF".

[Notes on use]

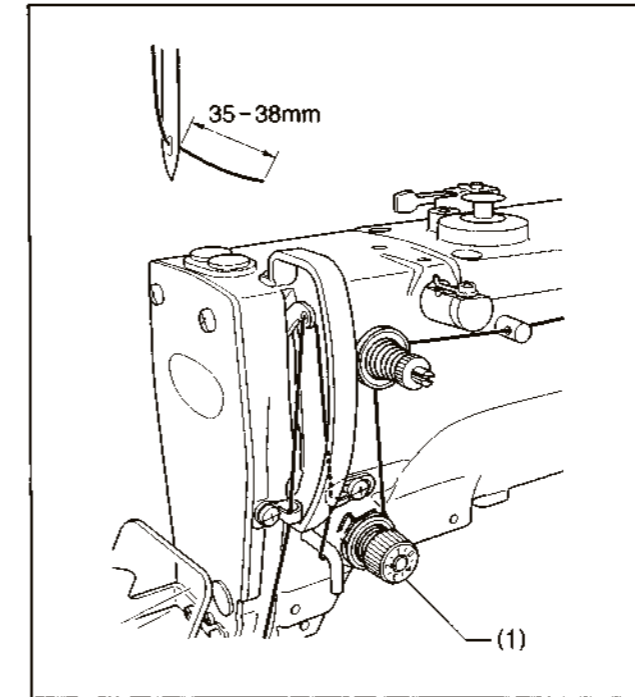

1. When using the thread nipper device, turn the tension nut (1) (sub-tension) to adjust the upper thread trailing length to 35 - 38 mm.
* Adjust the upper thread trailing length to less than 40 mm after replacing the upper thread also.

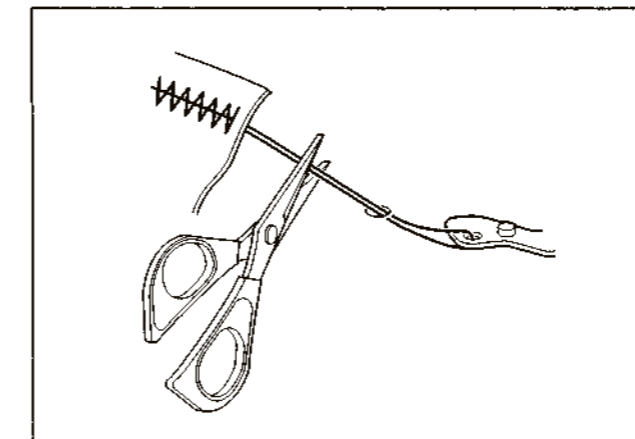

2. If the upper thread trailing length is 40 mm or more, or if the upper thread tension is weak and the upper thread does not form a good seam at the first stitch, the end of the thread that is being held by the thread nipper may become wound around the seam. Furthermore, if using thick thread that is #30 or higher or if the thread trailing length is too long, an error [E691] may occur. In any of these cases, use scissors to cut the thread without pulling it up too hard.

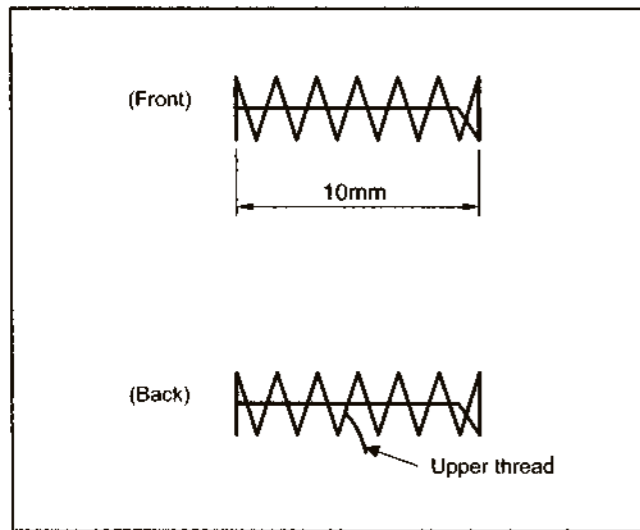

- For sewing patterns with a short bar tack length (10 mm or less), the end of the thread that is being held by the thread nipper may poke out from the seam on the underside of the material. It is recommended that you change the thread nipper setting to "OFF" for patterns such as these.
- If error [E690] or [E691] frequently occurs, remove the needle plate and remove any thread scraps from underneath the needle plate.

- With the CSM-430D, the lower thread may poke out from the underside of the material on the 2nd stitch for some types of material and thread. If this happens, it is recommended that you use sewing patterns that are designed for use with the thread nipper device. Refer to "2-2. Program list (CSM-430D)" for details of the sewing patterns.

<Program No. Reference Table>

Specifications	Standard program No.	Program No. for thread nipper device
For ordinary materials (-01)	1	65
	4	66
	5	67
	8	68
	13	69
	15	70
	20	71
For denim (-02)	21	72
	2	78
	3	79
	6	80
	14	81
	16	82
	17	83
For foundation garments (-07)	18	84
	19	85
	7	73
	9	74
	22	75
	31	76
	32	77

4-7. Inserting the button

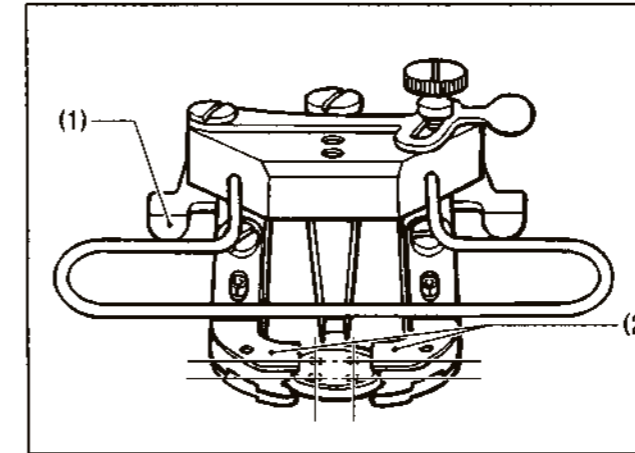

- Press the button clamp plate cam (1) to open the button holder (2).
- Insert the button, making sure that the button is facing the directing shown in the illustration, then release the button clamp plate cam (1).

4-8. Adjusting the button clamp

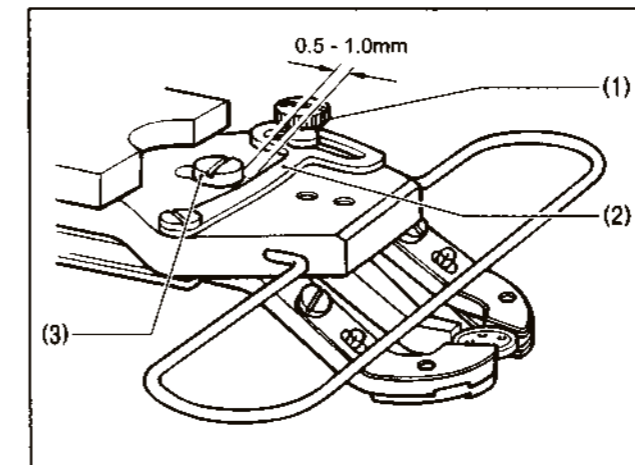

- Insert the button in the button clamp. Confirm that the button is securely held by the clamp.
- Loosen the shoulder screw (1), while the button is held by the clamp. Move the adjusting plate (2) so that the space between the adjusting plate (2) and screw (3) is approximately 0.5 - 1.0 mm, then tighten the shoulder screw (1).

4-9. Installing the accessory spring

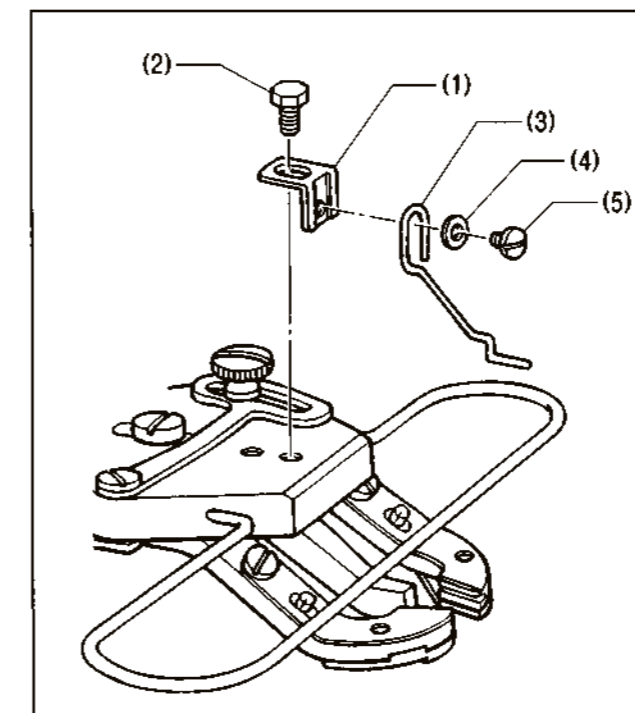

- If you would like the button to be raised up more after it is sewn, install the accessory spring.
- Install the spring support (1) with the bolt (2).
 - Install the spring (3) with the washer (4) and the screw (5).

5. USING THE OPERATION PANEL (BASIC OPERATIONS)

5-1. Name and function of each operation panel item

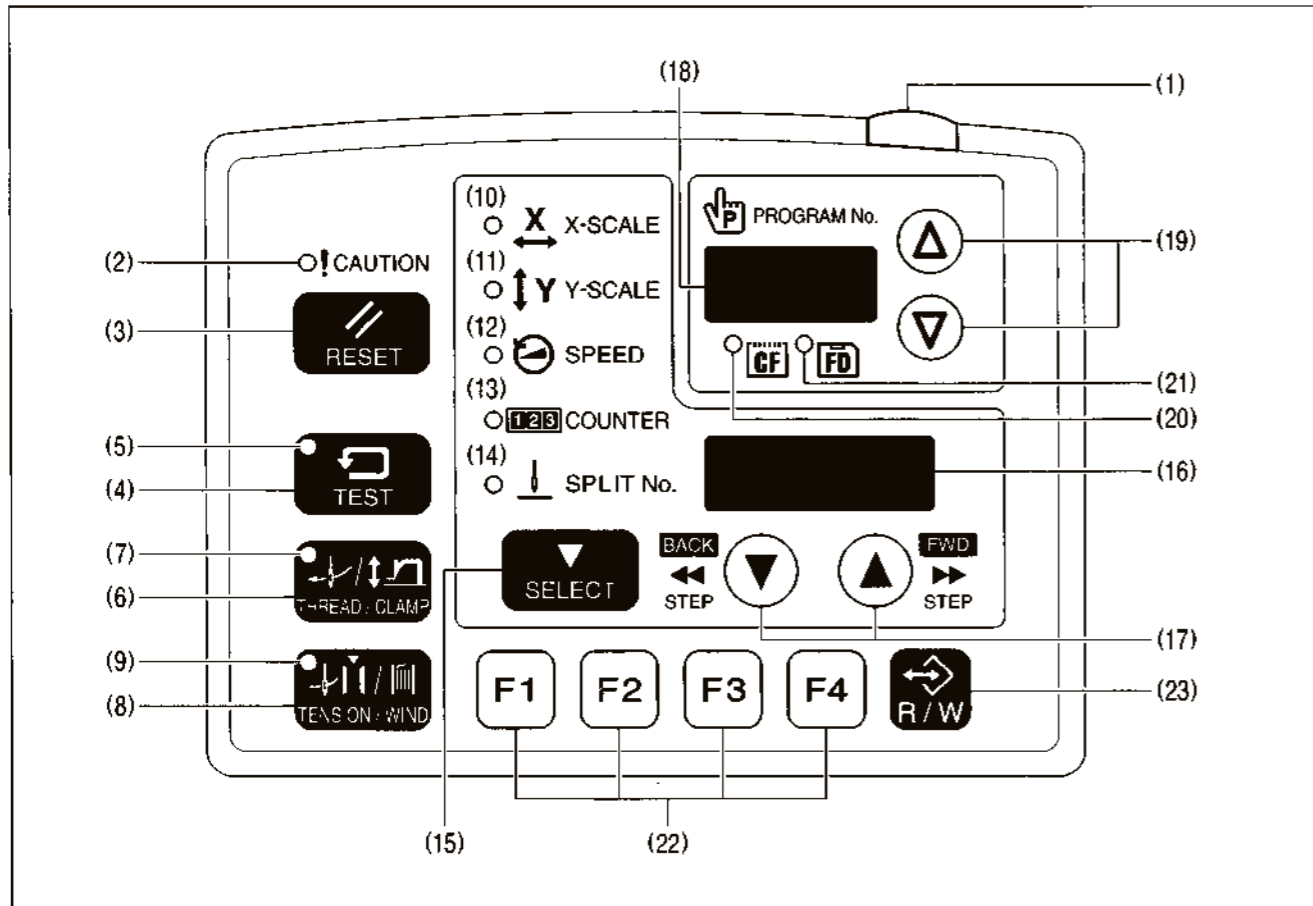

- (1) **Power indicator**
Illuminates when the power is turned on.
- (2) **CAUTION indicator**
Illuminates when an error occurs.
- (3) **RESET key**
Used to reset errors.
- (4) **TEST key**
Used to start test mode.
- (5) **TEST indicator**
Illuminates when the TEST key (4) has been pressed.
- (6) **THREAD/CLAMP key**
Used to start threading mode or work clamp height setting mode.
- (7) **THREAD/CLAMP indicator**
Illuminates when the THREAD/CLAMP key (6) has been pressed.
- (8) **TENSION/WIND key**
Used to wind the lower thread.
- (9) **TENSION/WIND indicator**
Spare

- (10) **X-SCALE indicator**
Illuminates when the SELECT key (15) is pressed to shown the X-scale setting.
- (11) **Y-SCALE indicator**
Illuminates when the SELECT key (15) is pressed to shown the Y-scale setting.
- (12) **SPEED indicator**
Illuminates when the SELECT key (15) is pressed to shown the sewing speed setting.
- (13) **COUNTER indicator**
Illuminates when the SELECT key (15) is pressed to shown the lower thread or production counter setting.
- (14) **SPLIT No. indicator**
Illuminates when the SELECT key (15) is pressed to show the split setting when split data (for specifying a pause while the program is running) exists.
- (15) **SELECT key**
Used to select a menu (X-scale, Y-scale, sewing speed and counter).
- (16) **Menu display**
Displays information such as menu setting values, memory switch settings and error codes.
- (17) **Setting keys** ▼ ▲
Used to change the value which is displayed in the menu display (16).
- (18) **PROGRAM No. display**
Displays information such as program numbers.
- (19) **Setting keys** ▽ ▴
Used to change the value which is displayed in the PROGRAM No. display (18).
- (20) **CF media indicator**
Illuminates when a CF card (external media) is inserted.
- (21) **FD media indicator**
Spare
- (22) **Function keys [F1, F2, F3, F4]**
Used to select user programs and to set and select cycle programs.
- (23) **R/W key**
Used to read data from and write data to external media.

5-2. Setting the program number

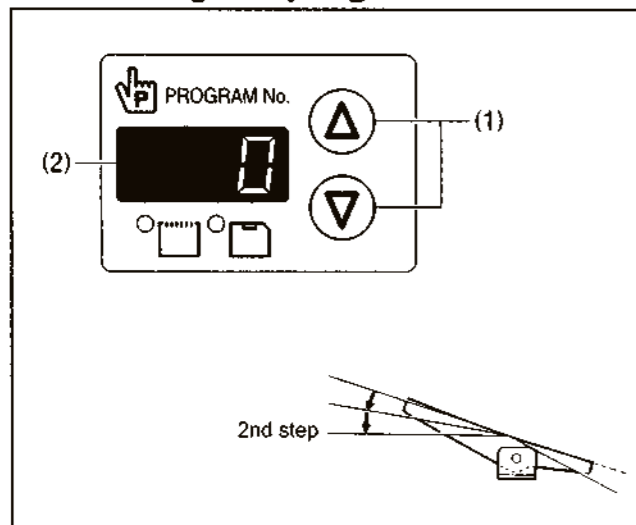

The program number is set to 0 (feed home position check) at the time of shipment from the factory.

1. Press the Δ or ∇ key (1) to select the program number.
 - The program number will flash in the PROGRAM No. display (2).
2. Depress the foot switch to the 2nd step.
 - The feed mechanism will move to the home position and the program number will be accepted.
 - The program number will stop flashing and illuminate steadily.

Note:

Once the setting is complete, be sure to carry out the steps in "5-5./5-6. Checking the sewing pattern" to check that the needle drop position is correct.

5-3. Setting the X-scale and Y-scale

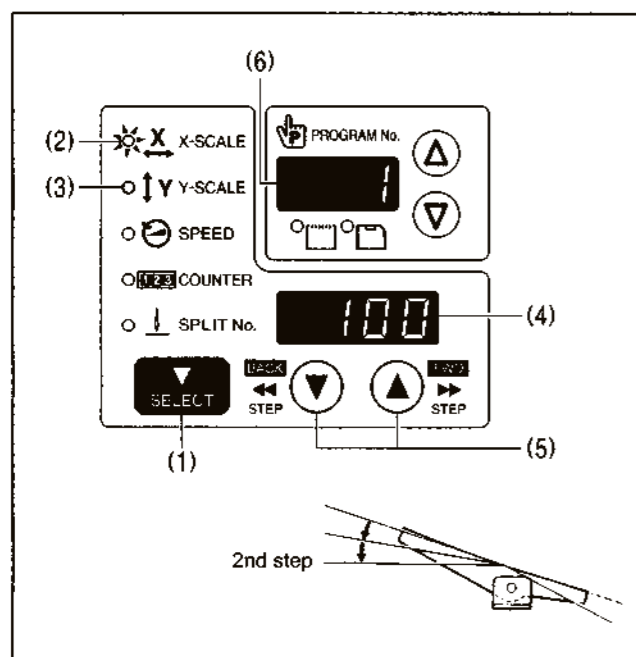

The scales are set to 100 (%) at the time of shipment from the factory.

1. Press the SELECT key (1) so that the X-SCALE indicator (2) (for X-scale setting) or the Y-SCALE indicator (3) (for Y-scale setting) is illuminated.
 - The setting value (%) will display in the menu display (4).
 - When memory switch no. 402 is set to "ON", the settings will be displayed in units of mm.
2. Press the Δ or ∇ key (5) to set the scale (20 - 200).
 - The program number will flash in the PROGRAM No. display (6).
3. Depress the foot switch to the 2nd step.
 - The feed mechanism will move to the home position and the scale will be accepted.
 - The program number will stop flashing and illuminate steadily.

Note:

Once the setting is complete, be sure to carry out the steps in "5-5./5-6. Checking the sewing pattern" to check that the needle drop position is correct.

5-4. Setting the sewing speed

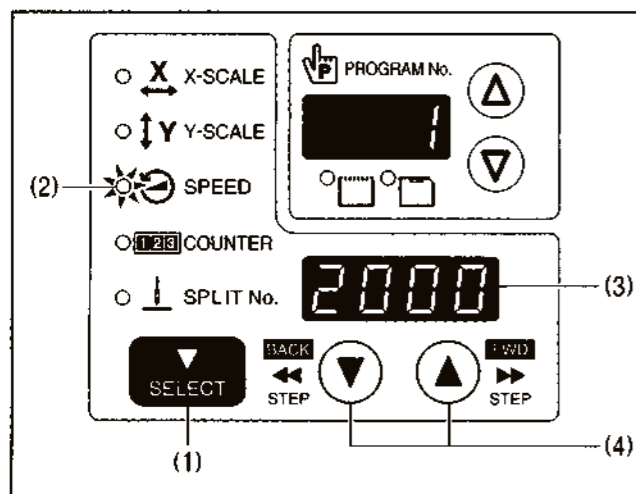

The sewing speed is set to 2000 (rpm) at the time of shipment from the factory.

1. Press the SELECT key (1) until the SPEED indicator (2) illuminates.
 - The setting value (rpm) will display in the menu display (3).
2. Press the Δ or ∇ key (4) to set the sewing speed. (Sewing speed setting values CSM-430D: 400 - 3200, CSM-438D: 400 - 2700)







5-5. Checking the sewing pattern

Use test feed mode to check the needle movement with only the feed mechanism operating. Check that the needle hole does not come out from the frame of the work clamp.

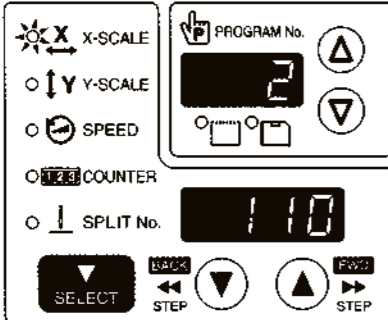
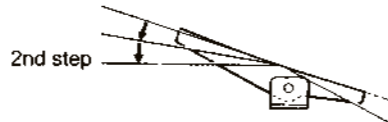
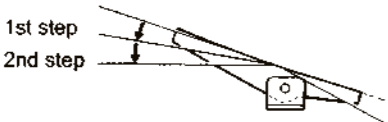
1		Press the TEST key.
2		<p>TEST indicator lights</p> <p>Select the program number to be checked, and then set the X-scale and the Y-scale.</p> <ul style="list-style-type: none"> • The program number will flash. <p>Depress the foot switch to the 2nd step.</p> <ul style="list-style-type: none"> • The feed mechanism will move to the home position and the program number will stop flashing and illuminate steadily.
Program number flashing → lit		
3	<p>Starting continuous test feed mode</p>	<p>Depress the foot switch to the 2nd step and then release it.</p> <ul style="list-style-type: none"> • Feed mechanism starts moving continuously one stitch at a time. <p>[Fast-forward test mode] If you depress the foot switch to the 1st step while the feed mechanism is moving, the feeding speed will become faster while the foot switch is being depressed.</p>
<p>[Sewing standby mode]</p>		
<p>TEST indicator switches off</p>		
<p>TEST indicator lights</p>		
<ul style="list-style-type: none"> • If you press the Δ key when in this mode, the feed will move forward one stitch, and if you press the ∇ key, the feed will move backward one stitch. (The feed will move quicker if you keep the key pressed down.) • If you would like to start test feed once more, press the TEST key. 		
4		<p>If test feeding continues to the final stitch, it will then stop.</p> <p>Press the TEST key.</p>
TEST indicator switches off		
5		<p>Depress the foot switch to the 1st step. The work clamp will rise and the preparation for sewing will be completed.</p>

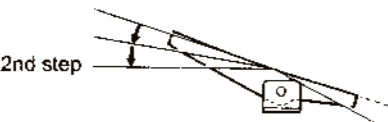

5-6. Checking the sewing pattern

Use test feed mode to check the needle movement with only the feed mechanism operating.

1		<p>Press the TEST key.</p>
TEST indicator lights		
2		<p>Select the program number to be checked, and then set the X-scale and the Y-scale.</p> <ul style="list-style-type: none"> The program number will flash. <p>Depress the foot switch to the 2nd step.</p> <ul style="list-style-type: none"> The feed mechanism will move to the home position and the program number will stop flashing and illuminate steadily.
 <p>2nd step</p>		
Program number flashing → lit		
3	<p>Set the button. (Refer to "4-7. Inserting the button".)</p>	
4	<p>Starting single-stitch test feed mode</p> <p>Depress the foot switch to the 2nd step and then release it.</p> <ul style="list-style-type: none"> The feed mechanism will move by one stitch only. 	
<p>1st step</p> <p>2nd step</p> 		
<p>After this, the feed mechanism will move forward by one stitch each time you depress the foot switch to the 1st step. Turn the pulley by hand each time the mechanism moves by one stitch, and check whether the needle drops into the hole of the button without touching the button. (If you turn the machine pulley one full rotation in the direction of sewing machine operation at this time, the feed mechanism will move forward by one stitch when the needle bar is near the needle up position.)</p> <p>In addition, if you depress the foot switch to the 2nd step again, the feed mechanism will start moving continuously one stitch at a time.</p>		
<p>[Sewing standby mode]</p> <p>If you would like sewing to start while test feeding is in progress, press the TEST key to switch off the TEST indicator.</p> <p>When you depress the foot switch to the 2nd step, sewing will start.</p> <p>TEST indicator switches off</p>   <p>2nd step</p> <p>   </p> <ul style="list-style-type: none"> If you press the ▲ key when in this mode, the feed will move forward one stitch, and if you press the ▼ key, the feed will move backward one stitch. (The feed will move quicker if you keep the key pressed down.) If you would like to start single-stitch test feed once more, press the TEST key. <p>TEST indicator lights</p>		
5	<p>Ending test feed mode</p> <p>Press the TEST key.</p> 	<p>TEST indicator switches off</p>
6	<p>Depress the foot switch to the 1st step.</p> <p>The work clamp will rise and the preparation for sewing will be completed.</p>  <p>1st step</p>	

5-7. Adjusting the work clamp / button clamp lift amount

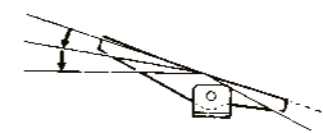
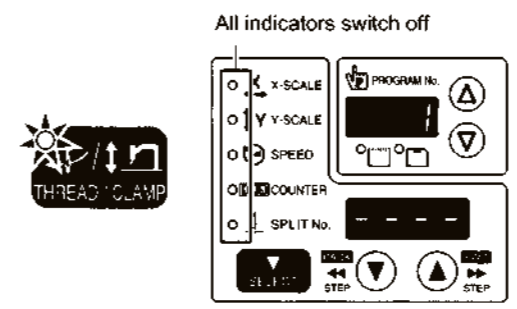
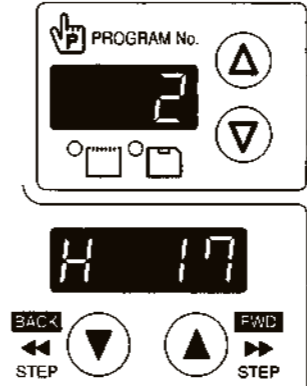
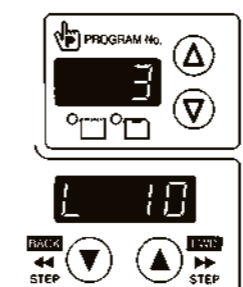
The setting for the work clamp/button clamp lift amount can be changed using the operation panel.

1		<p>Carry out home position detection.</p>
2	<p>All indicators switch off</p>  <p>THREAD/CLAMP indicator lights</p> <p>Menu indicators switch off</p>	<p>Press the THREAD/CLAMP key.</p> <p>The sewing machine will switch to threading mode.</p> <ul style="list-style-type: none"> " 1" will appear in the PROGRAM No. display, and the work clamp / button clamp will be lowered.
3		<p>Press the ▲ key.</p> <p>The sewing machine will switch to work clamp height setting mode.</p> <ul style="list-style-type: none"> " 2" will appear in the PROGRAM No. display and the work clamp/button clamp will rise to the setting value that appears in the menu display. (Work clamp height setting values CSM-430D: 10 - 17, CSM-438D: 6 - 13) <p>Note:</p> <p>If you press the ▲ key before home position detection has been carried out, the sewing machine will not switch to work clamp height setting mode. (The buzzer will sound.) Press the THREAD/CLAMP key to end setting mode and then repeat the procedure from step 1.</p> <p>Press the ▲ or ▼ key to set the work clamp height.</p> <ul style="list-style-type: none"> The work clamp/button clamp will rise or drop to the height of the new value that has been set.
<p>When memory switch no.003 is "ON"</p>  <p>Press the ▲ key.</p> <p>The sewing machine will switch to intermediate work clamp height setting mode.</p> <ul style="list-style-type: none"> " 3" will appear in the PROGRAM No. display and the work clamp/button clamp will move to the setting value that appears in the menu display. (Intermediate work clamp height setting values CSM-430D: 1 - 17, CSM-438D: 1 - 13) <p>Press the ▲ or ▼ key to set the intermediate work clamp height.</p> <ul style="list-style-type: none"> The work clamp/button clamp will rise or drop to the height of the new value that has been set. 		
<p><Switching modes></p> <p>[2] Work clamp height setting mode</p> <p style="text-align: center;">↑</p> <p>[3] Intermediate work clamp height setting mode</p> <p style="text-align: center;">↑</p> <p>[1] Threading mode</p>		
4	<p>Ending setting mode</p> 	<p>THREAD/CLAMP indicator switches off</p>
<p>Press the THREAD/CLAMP key.</p> <ul style="list-style-type: none"> The setting values will be memorized. The work clamp/button clamp will return to the status that it was at before the sewing machine was switched to setting mode. 		

6. USING THE OPERATION PANEL (ADVANCED OPERATIONS)

6-1. List of advanced functions

While holding down the TEST key, press the corresponding combination key.

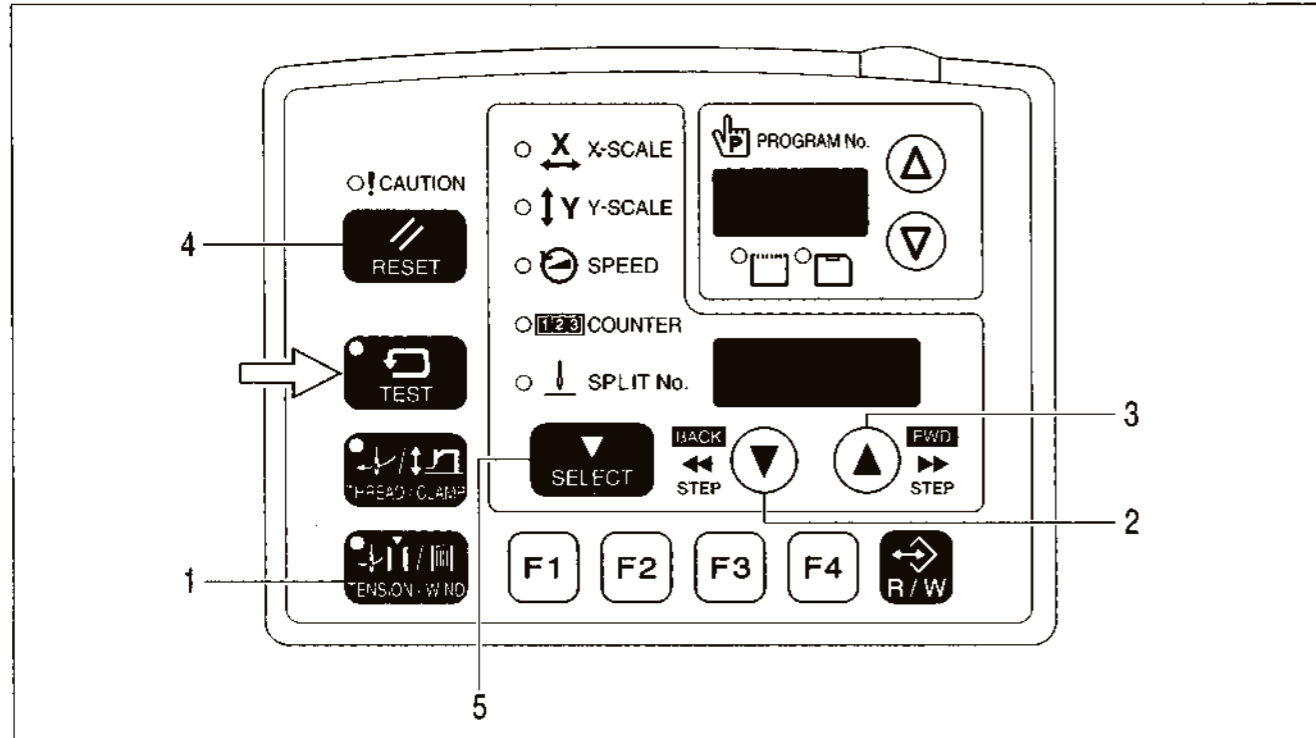

1	+	Memory switch setting mode Refer to "6-2. Setting memory switches".
2	+	Lower thread counter setting mode Refer to "6-4. Using the lower thread counter".
3	+	Production counter setting mode Refer to "6-5. Using the production counter".
4	When the SPEED indicator lights +	Production counter temporary display function Refer to "6-5. Using the production counter".
5	+	User program setting mode Refer to "6-6. Using user programs".

6-2. Setting memory switches

1

All indicators switch off

While pressing the SELECT key, turn on the power switch.
* Keep pressing the SELECT key until the model name is displayed and the buzzer beeps once.

Or
With the power turned on, press the TEST key and the TENSION/WIND key simultaneously.

• The memory switch number will appear in the PROGRAM No. display, and its setting value will appear in the menu display.

Menu indicators switch off
TEST indicator lights

2

Press the Δ or ∇ key to select the memory switch number.

Press the Δ or ∇ key to change the setting value.

If you would like to display only the numbers of memory switches that have been changed from default settings

While pressing the SELECT key, press the Δ or ∇ key.

- The numbers of memory switches that have been changed from default settings will appear in order.
- If no memory switches have been changed from their default settings, the display will not change and the buzzer will beep twice.

3 Ending setting mode

Press the TEST key.

- The changes will be memorized and the sewing machine will switch to home position detection standby.

TEST indicator switches off

- If you would like to return the setting for a single memory switch to the default setting, press the RESET key while the number for that memory switch is displayed.
- To return the settings for all memory switches to the default settings, keep pressing the RESET key for **two or more seconds** until the buzzer makes a long beep.

6-3. List of memory switches

No.	Setting range	Setting items	Default
001	Work clamp/button clamp lift timing when sewing is complete		OFF
	OFF	Lifts at the final stitch position.	
	ON	Lifts after moving to the home position.	
003	2-step work clamp		OFF
	OFF	Disable	
	ON	Stops at intermediate work clamp height setting mode when foot switch is depressed to 1st step, and then drops fully and sewing starts when foot switch is depressed to 2nd step.	
100	Sewing start speed		*1
	OFF	The sewing speed for the first 1 - 5 stitches is set by memory switch nos. 151 - 155. (Refer to the Service Manual for details of memory switch nos. 151 - 155.)	
	ON	CSM-430D: 1st stitch sewn at 400 rpm and 2nd stitch sewn at 800 rpm CSM-438D: 1st and 2nd stitches sewn at 400 rpm	
200	Single-stitch test feed		*1
	OFF	Test feed starts when the foot switch is depressed, and it continues automatically until the final stitch.	
	ON	Test feeding is carried out stitch by stitch when the foot switch is depressed. In addition, when the test indicator is illuminated, test feeding will move forward one stitch at a time when the machine pulley is turned by hand.	
300	Production counter display		OFF
	OFF	Lower thread counter display	
	ON	Production counter display	
400	User programs		OFF
	OFF	Disable	
	ON	User program mode is enabled.	
401	Cycle programs		OFF
	OFF	Disable	
	ON	When sewing user programs, the set programs are sewn in numeric order.	
402	Units display for pattern zoom ratio (*2)		OFF
	OFF	Displayed as %.	
	ON	Displayed as mm.	
500	Thread clamp device		OFF
	OFF	Disable	
	ON	Thread clamp device can be used. (*3)	

*1 Off for CSM-430D and ON for CSM-438D.

*2 The mm display may differ slightly from the actual sewing size.

*3 May not operate if the settings for the memory switch nos. 151 and 152 have been changed, or at some sewing speeds. (Refer to the Service Manual for details of memory switch nos. 151 and 152.)

6-4. Using the lower thread counter

If you use the bobbin thread counter to set the number of articles which can be sewn with the amount of bobbin thread available, you can stop the bobbin thread running out in the middle of sewing a pattern.

<Initial value setting>

1 While pressing the TEST key press the ▼ key.

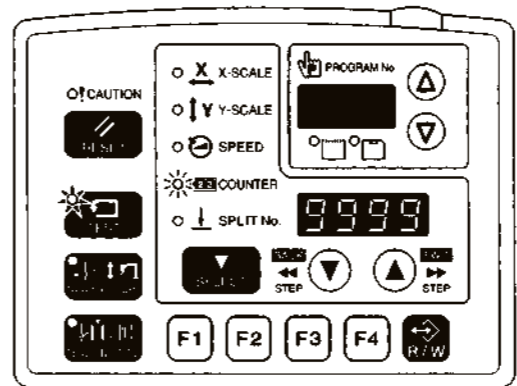

TEST indicator lights, COUNTER indicator flashes

2 Press the ▲ or ▼ key to set the initial value.

- The initial value can be set from 1 ("0001") to 9999 ("9999").
- If the initial value is set to "0000", the lower thread counter will not operate.
- If you press the RESET key during setting mode, the value will become "0000".

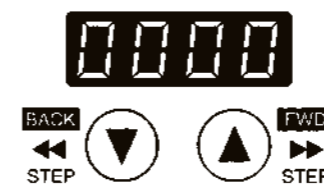

3 Ending setting mode

Press the TEST key.

- The initial value will be memorized.



TEST indicator switches off

<Lower thread counter operation>



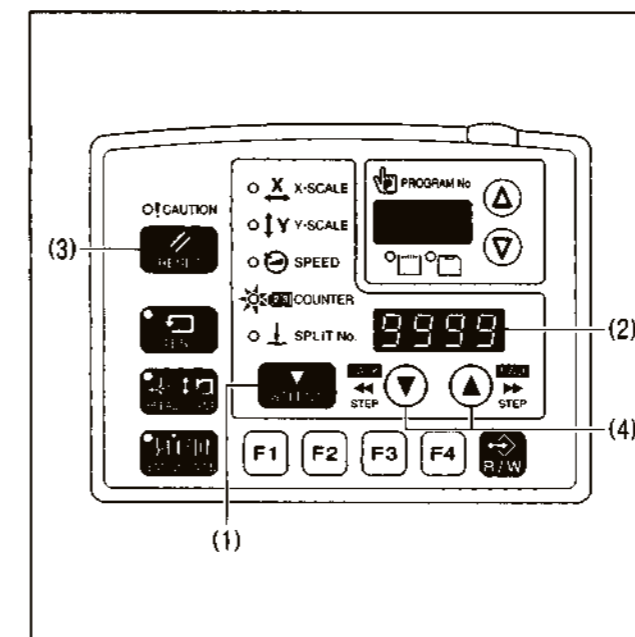

If you press the SELECT key (1) to select the counter display menu when memory switch no. 300 is set to "OFF", the COUNTER indicator will illuminate and the lower thread counter will appear in the menu display (2).

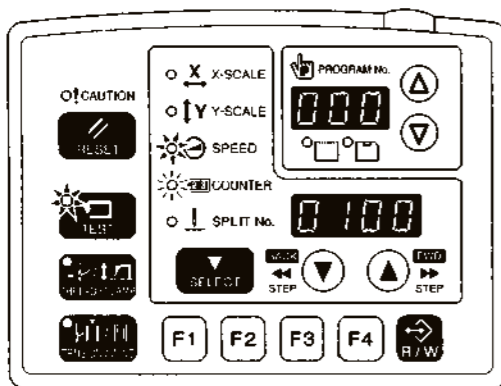

- Each time the sewing of a single article is completed, the value shown in the menu display (2) is reduced by 1.
- When the lower thread counter reaches "0000", the buzzer will sound. The sewing machine will not operate during this time, even if the foot switch is depressed.
- When you press the RESET key (3), the buzzer will stop, the initial value will appear in the menu display (2) and sewing will be possible.
 - If no initial value has been set, the display will be "0000".
- You can press the ▲ or ▼ key (4) to set the lower thread counter to the desired value. However, this value will not be memorized as the initial value.
- If a lower thread counter value is set, the lower thread counter will operate even if the lower thread counter is not being displayed.

6-5. Using the production counter

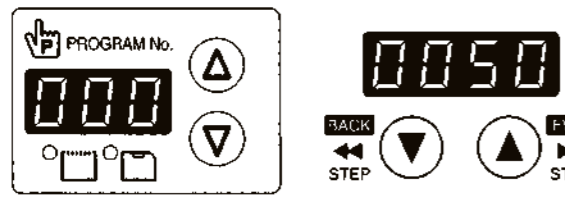
<Setting the counter value>

<p>1</p>  <p>TEST indicator and SPEED indicator light COUNTER indicator flashes</p>	<p>While pressing the TEST key, press the ▲ key.</p>   <ul style="list-style-type: none"> The counter value will appear in the PROGRAM No. display and the menu display as a 7-digit number.
<p>2</p> 	<p>Press the ▲ or ▼ key to set the counter value.</p> <ul style="list-style-type: none"> The counter value can be set from [000][0000] to [999][9999]. If you press the RESET key during setting mode, the value will become [000][0000].
<p>3 Ending setting mode</p>  <p>TEST indicator switches off</p>	<p>Press the TEST key.</p> <ul style="list-style-type: none"> The counter value will be memorized.

<Production counter operation>

If you press the SELECT key (1) to select the counter display menu when memory switch no. 300 is set to "ON", the SPEED and COUNTER indicators will illuminate and the production counter will appear in the menu display (2).

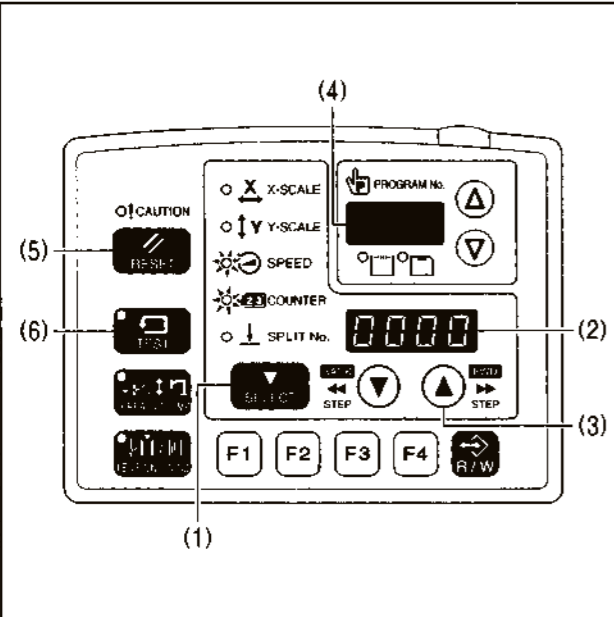

(1) SELECT key
(2) Counter display
(3) ▲ key
(4) PROGRAM No. display
(5) RESET key
(6) TEST key

- Each time the sewing of a single article is completed, the value shown in the menu display (2) is increase by 1.
- The first three digits will appear in the PROGRAM No. display (4) while the ▲ key (3) is being pressed, so that the total number of digits displayed will be 7.
- If you press the RESET key (5) for 2 seconds or more, the counter value will be reset to [0000].

Temporary display function

You can display the production counter temporarily while the lower thread counter is being displayed.

When the SPEED indicator is illuminated, hold down the TEST key (6) and then press the RESET key (5) to display the production counter in the menu display (2).

Press the TEST key (6) or the SELECT key (1) to switch the menu back to the normal menu display.

* Sewing can continue as normal while the temporary display is active.









6-6. Using user programs

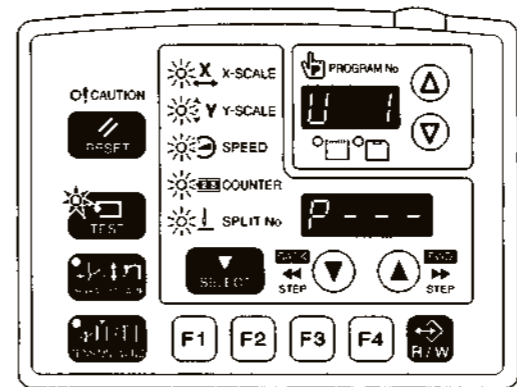

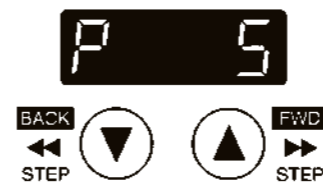
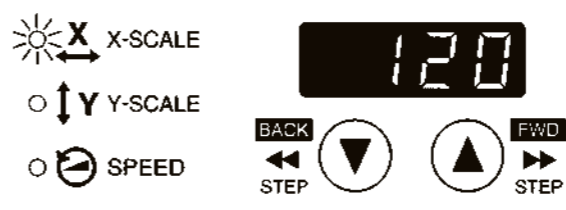

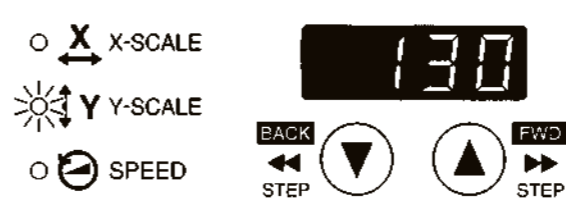

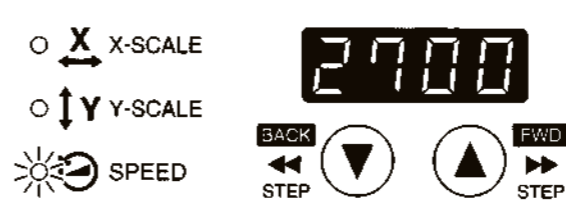

Up to 50 different combinations of settings including program no., X-scale, Y-scale, sewing speed and work clamp height can be memorized as user programs (U1 to U50).

If you are sewing certain patterns over and over again, it is useful to record the settings for these patterns into a user program.

User programs are enabled when memory switch no. 400 is set to "ON".

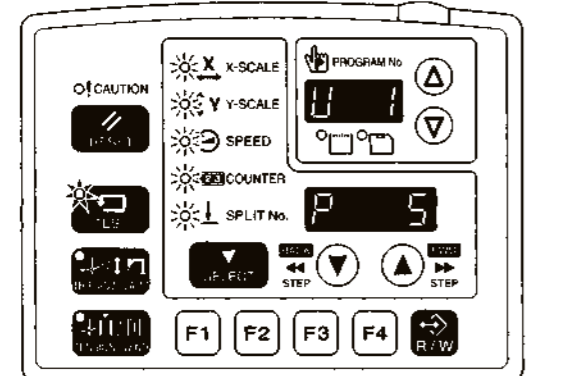
<Recording the user programs>

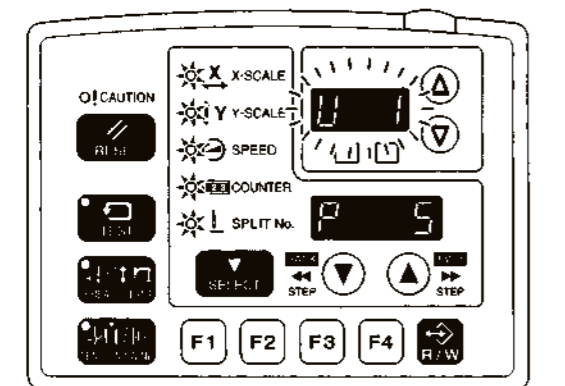
<p>1 Select a user program number.</p>  <p>TEST indicator lights Menu indicators flash</p>	<p>While pressing the TEST key, press the SELECT key.</p>   <ul style="list-style-type: none"> Switch to user program recording mode. Check that the menu indicators are flashing. User program number will appear in the PROGRAM No. display, and "P--" will appear in the menu display. <p>Press the ▲ or ▼ key to select a user program number.</p>
<p>2 First, set the program number.</p> 	<p>Press the ▲ or ▼ key to set the program number that you would like to record.</p>
<p>3 Next, set the X-scale.</p>  <p>X-SCALE indicator flashes</p>	<p>Press the SELECT key.</p>  <p>Press the ▲ or ▼ key to set the X-scale that you would like to record.</p>
<p>4 Next, set the Y-scale.</p>  <p>Y-SCALE indicator flashes</p>	<p>Press the SELECT key.</p>  <p>Press the ▲ or ▼ key to set the Y-scale that you would like to record.</p>
<p>5 Next, set the sewing speed.</p>  <p>SPEED indicator flashes</p>	<p>Press the SELECT key.</p>  <p>Press the ▲ or ▼ key to set the sewing speed that you would like to record.</p>

<p>6</p>	<p>Next, set the work clamp height.</p>  <p>THREAD/CLAMP indicator flashes</p>	<p>Press the SELECT key.</p>  <p>Press the ▲ or ▼ key to set the desired work clamp height.</p>
<p>7</p>	<p>Next, set the intermediate work clamp height (only when memory switch no. 003 is "ON").</p>  <p>THREAD/CLAMP indicator flashes</p>	<p>Press the SELECT key.</p>  <p>Press the ▲ or ▼ key to set the desired intermediate work clamp height.</p>
<p>8</p>	 <p>TEST indicator lights Menu indicators flash</p>	<p>Press the SELECT key.</p>  <ul style="list-style-type: none"> If setting further user programs, select the user program number and then repeat steps 2 to 8.
<p>9</p>	 <p>TEST indicator switches off Menu indicators light</p>	<p>Press the TEST key.</p>  <p>This completes the recording of a user program.</p> <ul style="list-style-type: none"> The user program number will flash in the PROGRAM No. display, and the sewing machine will switch to home position detection standby.



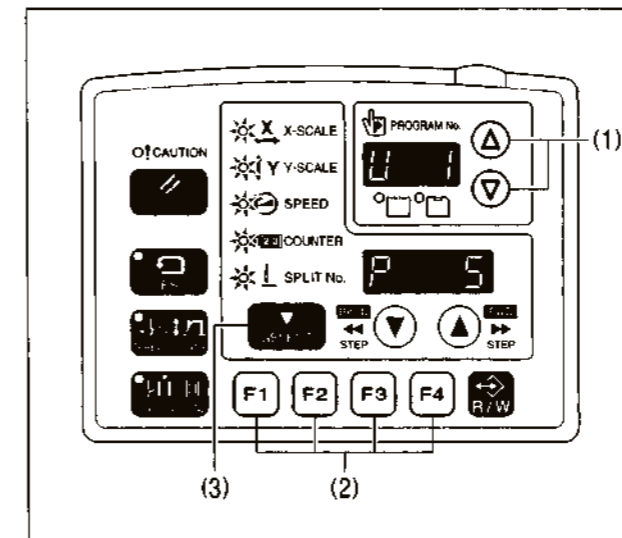

<Using a user program>

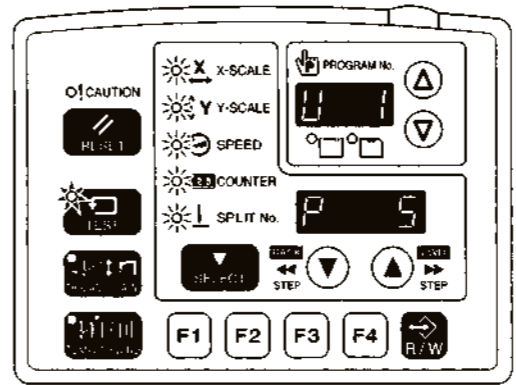

- Press the ▲ or ▼ key (1) to select the user program number that you would like to use.
 - If the user program number is flashing, depress the foot switch to move the feed mechanism to the home position. After this, it is not necessary to detect the home position until the next time the power is turned off and back on, even if you change the user program number.
 - User programs U1 to U10 can be selected directly using function keys F1 to F4 (2). (Refer to "6-8. Direct selection".)
- Check that the needle drop position is correct, and then start sewing. (Refer to "5-5. /5-6. Checking the sewing pattern".)

- If you press the SELECT key (3), you can check the settings for the displayed user program (such as X-scale, Y-scale and sewing speed).





<Clearing a user program>

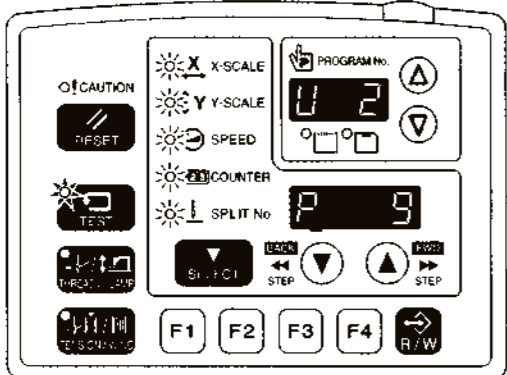

<p>1</p>	 <p>TEST indicator lights Menu indicators flash</p>	<p>While pressing the TEST key, press the SELECT key.</p>   <ul style="list-style-type: none"> Switch to user program recording mode. Check that the menu indicators are flashing. User program number will appear in the PROGRAM No. display, and the program number will appear in the menu display. <p>Press the ▲ or ▼ key to select the user program number which is to be cleared of data.</p>
<p>2</p>	 <p>Clearing all user programs</p>	<p>Press the RESET key.</p> <ul style="list-style-type: none"> The buzzer will sound and the user program with the number selected will be cleared. <p>Note: If a cleared user program has been stored as part of a cycle program, the step that involves that user program will become blank. The cycle program itself will not be cleared.</p> <p>Press and hold the RESET key for 2 seconds or more.</p> <ul style="list-style-type: none"> The buzzer will sound and the all user programs will be cleared. <p>Note: If any cycle programs have been memorized, all of the memorized cycle programs will also be cleared.</p>

6-7. Using cycle programs

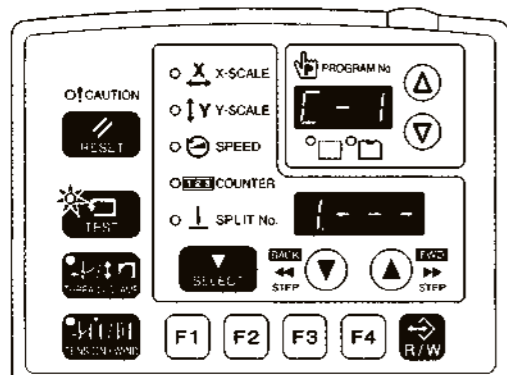
Sewing patterns that have been recorded in user programs can be recorded in up to nine cycle programs (C-1 to C-9). One cycle program can contain up to a maximum of fifteen steps. When sewing the sewing patterns in numerical order, it can be useful to record them in a cycle program beforehand. **Cycle programs are enabled when memory switch nos. 400 and 401 are set to "ON".**

<Recording the cycle programs>

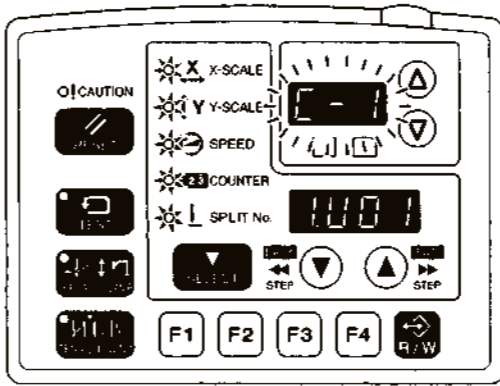
<p>1 Switch to user program recording mode.</p>  <p>TEST indicator lights Menu indicators flash</p>	<p>While pressing the TEST key, press the SELECT key.</p>  <ul style="list-style-type: none"> • Check that the menu indicators are flashing. • User program number will appear in the PROGRAM No. display, and the program number will appear in the menu display. <p>Record the sewing patterns into a user program so that they can be recorded in a cycle program.</p>
<p>2 Switch to cycle program recording mode, and select the cycle program number.</p>  <p>Menu indicators switch off</p>	<p>Press a function key from F1 to F4.</p>  <ul style="list-style-type: none"> • Cycle program number will appear in the PROGRAM No. display, and "1. - - -" will appear in the menu display. <p>Press a function key from F1 to F4, or press the Δ or ∇ key to select a cycle program number.</p>
<p>3 Set the step 1.</p> 	<p>Press the Δ or ∇ key to set the program number that you would like to record.</p> <p>Press the SELECT key.</p>
<p>4 Set the rest of the steps in the same way from step 2 onward. From step 9 onward, "A.---", "b.---", "c.---", "d.---", "E.---" and "F.---" will be displayed.</p> <p>If you would like to return to a previous step during the setting procedure</p> <p><For cycle programs C-1 to C-4></p> <ol style="list-style-type: none"> 1. Press the respective function key from F1 to F4 to return to the display for step 1. 2. Press the SELECT key until the desired step is reached. <p><For cycle programs C-5 to C-9></p> <ol style="list-style-type: none"> 1. Press the Δ or ∇ key to change the cycle program number. 2. Select the desired cycle program number again, and then press the SELECT key until the desired step is reached. 	

<p>5 To record another cycle program, repeat steps 2 to 4.</p>	
<p>6 End cycle program recording mode.</p>  <p>TEST indicator switches off Menu indicators light</p>	<p>Press the TEST key.</p>  <p>This completes the recording of cycle programs.</p> <ul style="list-style-type: none"> • The cycle program number will flash in the PROGRAM No. display, and the sewing machine will switch to home position detection standby.

<Using a cycle program>

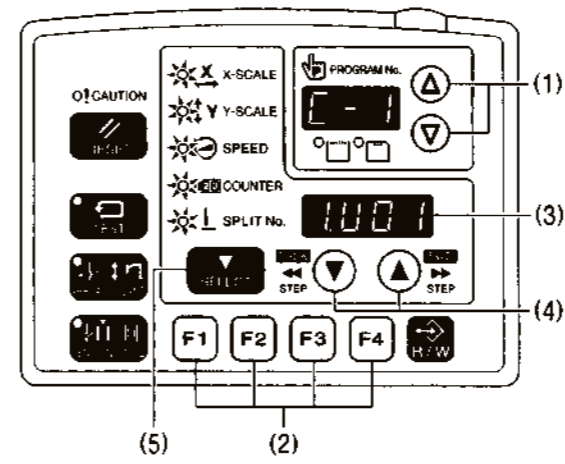
	<ol style="list-style-type: none"> 1. Press the Δ or ∇ key (1) to select the cycle program number that you would like to use. <ul style="list-style-type: none"> • If the cycle program number is flashing, depress the foot switch to move the feed mechanism to the home position. After this, it is not necessary to detect the home position until the next time the power is turned off and back on, even if you change the cycle program number. • The cycle program number can be selected directly by pressing function keys F1 to F4 (2). (Refer to "6-8. Direct selection".) 2. Check that the needle drop position is correct, and then start sewing. (Refer to "5-5./5-6 Checking the sewing pattern".) 3. The recorded user program will be sewn step by step, and when the final step is complete, the menu display (3) will return to showing step 1.
<ul style="list-style-type: none"> • If you press the Δ or ∇ key (4), you can return to the previous step or skip to the next step respectively. (You do not need to carry out home position detection again.) • If you press the SELECT key (5), you can check the details (such as X-scale, Y-scale and sewing speed) of the user program for the displayed step. The setting cannot be changed at this time. <p>Note: If cycle program sewing mode is active (when memory switch no. 401 is "ON") but no cycle programs have been recorded, the user programs will be sewn in numeric order.</p>	

< Clearing a cycle program >

1

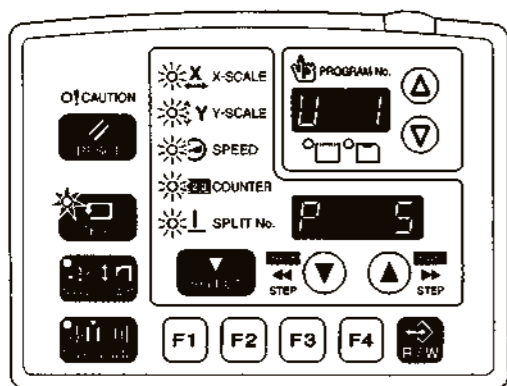

While pressing the TEST key, press the SELECT key.

TEST SELECT

- Switch to user program recording mode. Check that the menu indicators are flashing.

TEST indicator lights
Menu indicators flash

2

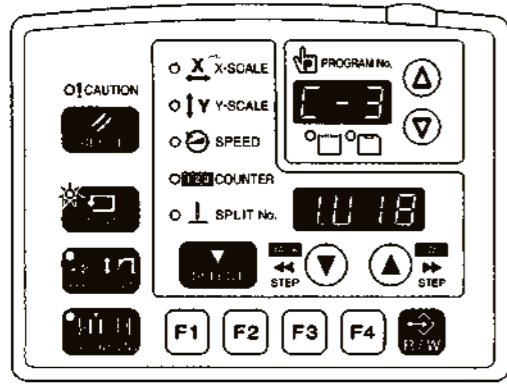

Press a function key from F1 to F4.

F1 F2 F3 F4

- Switch to cycle program recording mode.

Press a function key from F1 to F4, or press the Δ or ∇ key to select the cycle program number to be cleared.

Menu indicators switch off

3



Press the RESET key.

- The buzzer will sound and the cycle program with the number selected will be cleared.

Clearing all cycle programs

Press and hold the RESET key for 2 seconds or more.

- The buzzer will sound and the all cycle programs will be cleared.

Note:
If you clear all user programs after any cycle programs have been recorded, all recorded cycle programs will also be cleared.

6-8. Direct selection

You can use the function keys to directly select user program numbers and cycle program numbers. U1 to U4 and C-1 to C-4 can be selected using function keys F1 to F4. U5 to U10 and C-5 to C-9 can be selected by simultaneously pressing combinations of function keys F1 to F4 (addition).

<Key combination table>

U5 / C-5	U6 / C-6	U7 / C-7
F1 + F4	F2 + F4	F3 + F4
Or	Or	Or
F2 + F3	F1 + F2 + F3	F1 + F2 + F4
U8 / C-8	U9 / C-9	U10
F1 + F3 + F4	F2 + F3 + F4	F1 + F2 + F3 + F4

6-9. Loading additional sewing data

1

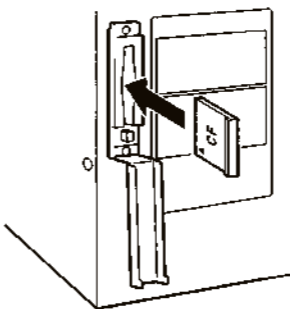

With the power turned off, insert the CF card into the CF slot.

Note:

- Make sure the CF card is facing the correct way.
- The cover should be closed at all times except when the CF card is inserted and removed, otherwise dust may cause trouble.

2

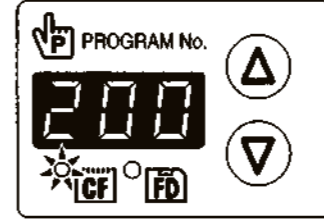

Turn on the power switch.
Press the Δ or ∇ key to select the program number (200 to 999).

CF media indicator lights

3

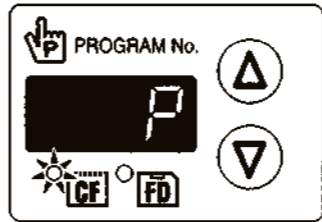

Press the R/W key.

R/W

- The buzzer will sound and the selected sewing data will be loaded from the CF card and copied into the sewing machine's internal memory.

While reading

4 End reading.

- The program No. display will change from " P" to the selected program number.

7. SEWING

CAUTION

- Turn off the power switch at the following times, otherwise the machine may operate if the foot switch is depressed by mistake, which could result in injury.
- When threading the needle
 - When replacing the needle and bobbin
 - When not using the machine and when leaving the machine unattended
- Do not touch any of the moving parts or press any objects against the machine while sewing, as this may result in personal injury or damage to the machine.

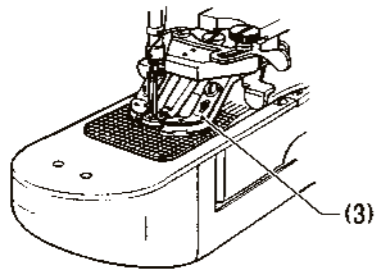
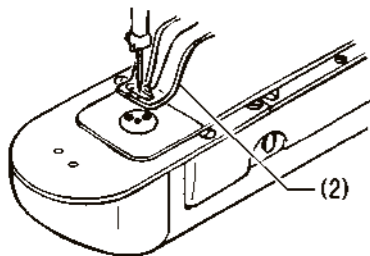
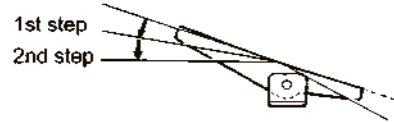
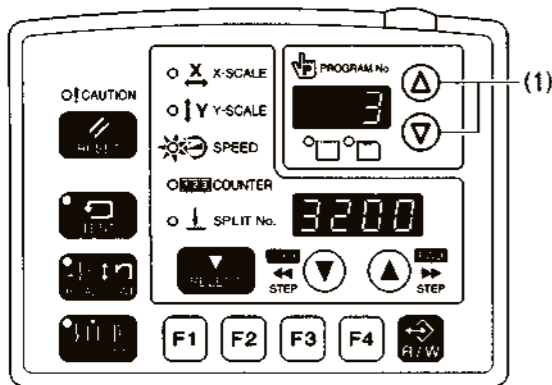

1. Turn on the power switch.
 2. Press the Δ or ∇ key (1) to select the number for the program to be sewn.
 3. Depress the foot switch to the 2nd step.
The feed mechanism will move to the home position.
 4. Set the material under the work clamp (2).
(For the CSM-438D, insert the button and place the material under the button clamp (3). (Refer to "4-7. Inserting the button".))
 5. Depress the foot switch to the 1st step.
The work clamp (2) / button clamp (3) will be lowered.
 6. Depress the foot switch to the 2nd step.
The sewing machine will start sewing.
- * If memory switch no. 003 is set to "ON", the work clamp (2)/button clamp (3) will drop to the intermediate stop position when the foot switch is depressed to the 1st step, and when it is depressed to the 2nd step, the material will be held and sewing will start.
7. Once sewing is completed and the thread has been trimmed, the work clamp (2) / button clamp (3) will rise.

8. MAINTENANCE

CAUTION

- Turn off the power switch before carrying out cleaning, otherwise the machine may operate if the foot switch is pressed by mistake, which could result in injury.
- Be sure to wear protective goggles and gloves when handling the lubricating oil and grease, so that they do not get into your eyes or onto your skin, otherwise inflammation can result. Furthermore, do not drink the oil or eat the grease under any circumstances, as they can cause vomiting and diarrhoea. Keep the oil out of the reach of children.

8-1. Cleaning the rotary hook

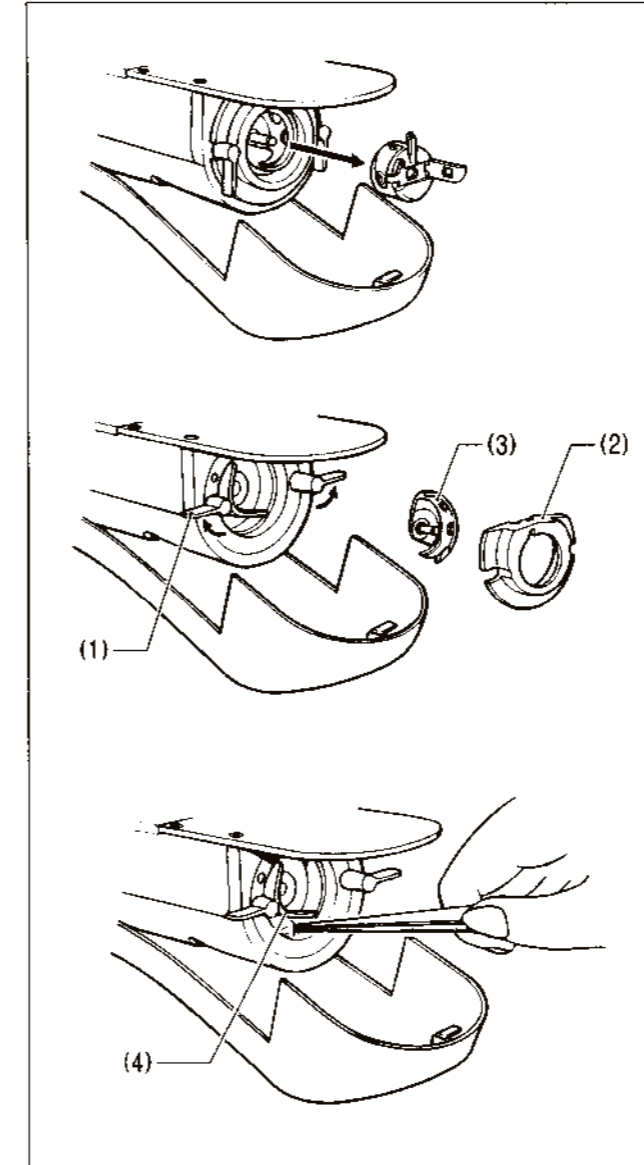

1. Pull the shuttle race cover downward to open it, and then remove the bobbin case.
2. Open the setting claw (1) in the direction indicated by the arrow, and then remove the shuttle race base (2) and the shuttle hook (3).
3. Clean all the dust and thread ends from around the driver (4), the top of the rotary hook thread guide and the shuttle race.

8-2. Cleaning the control box air inlet ports

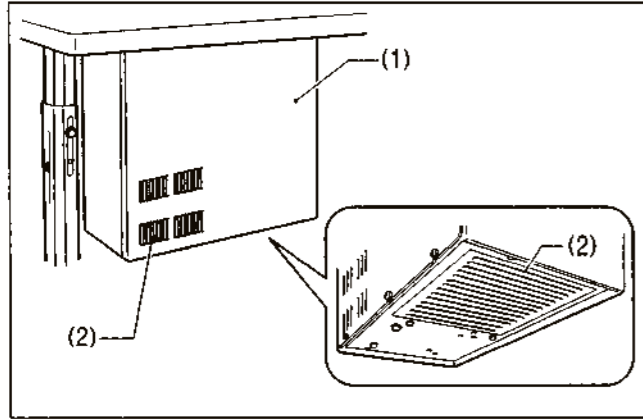

Use a vacuum cleaner to clean the filter in the air inlet ports (2) of the control box (1) at least once a month.

8-3. Draining the oil

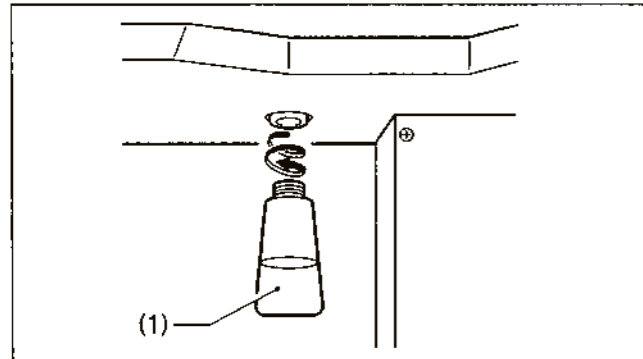

1. Remove and empty the waste oil container (1) whenever it is full.
2. After emptying the waste oil container (1), screw it back into its original position.

8-4. Cleaning the eye guard

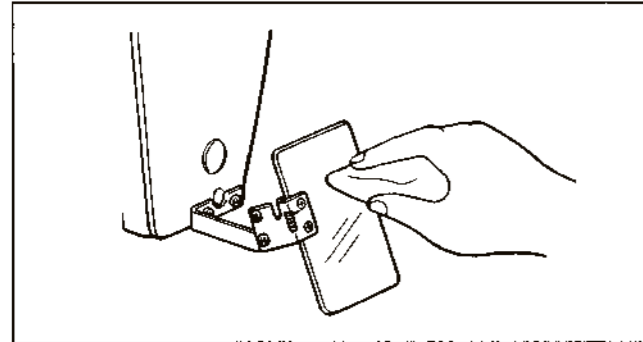

Wipe the eye guard clean with a soft cloth.

Note:

Do not use solvents such as kerosene or thinner to clean the eye guard.

8-5. Checking the needle

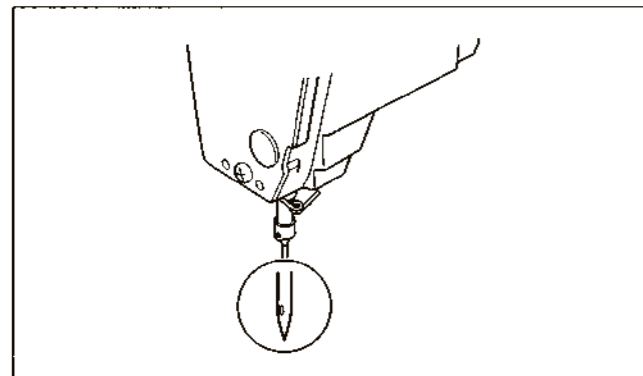

Always check that the tip of the needle is not broken and also the needle is not bent before starting sewing.

8-6. Lubrication

Carry out the lubrication referring to "3-13. Lubrication".

8-7. Applying grease (When "GREASEUP" appears)

If "GrE" and "AS.UP" flash on the PROGRAM No. display (1) and the menu display (2) respectively, and a buzzer sounds when the power switch is turned on, it means that grease needs to be applied. (The sewing machine will not operate at this time, even if the foot switch is depressed.)

Apply grease as required, while referring to the following for details.

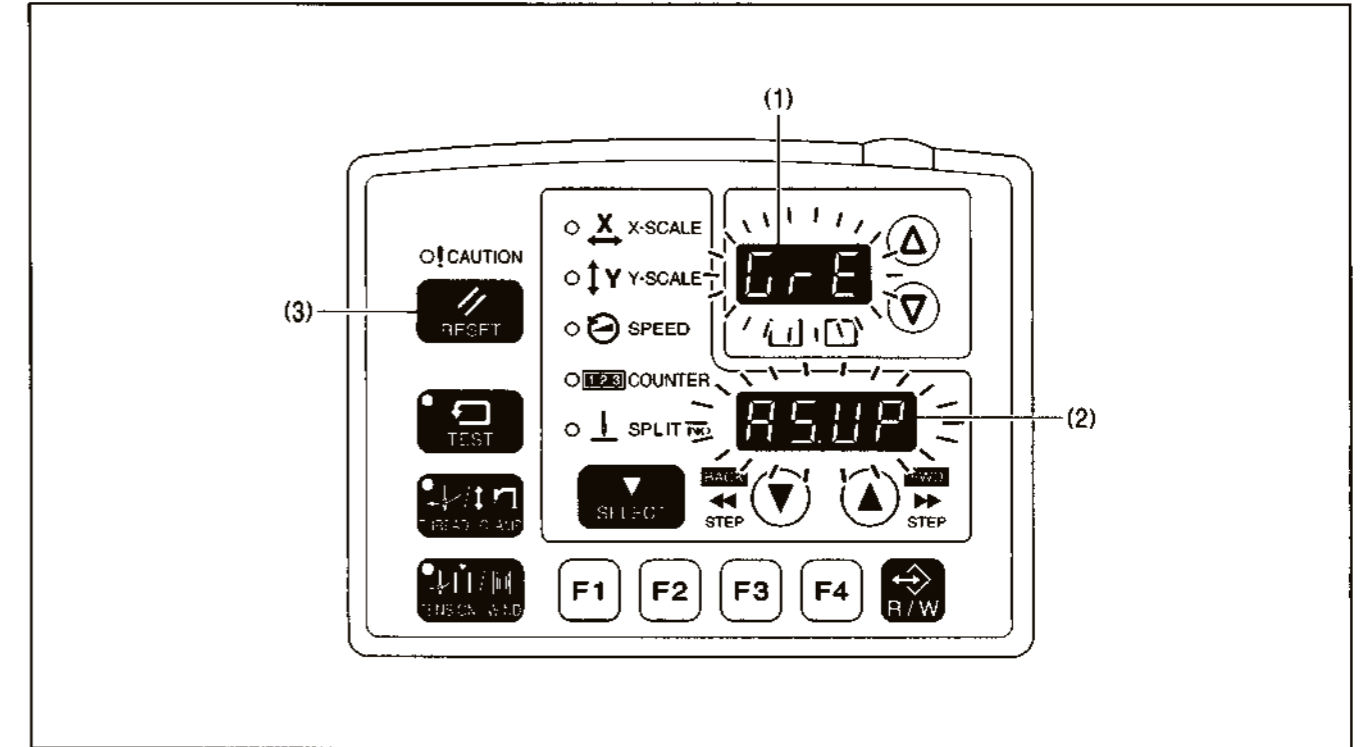

<To continue sewing temporarily without applying grease>

1. Press the RESET key (3).
2. The PROGRAM No. display (1) and the menu display (2) will change to the normal displays, and sewing can be carried out by depressing the foot switch.

Note:

- "GrE" and "AS.UP" will continue to be displayed each time the power is turned on until grease is applied and the notification is reset by carrying out the procedure on the separate page.
- If you continue to use the sewing machine after the "GrE" and "AS.UP" notification appears without applying grease (or without carrying out the reset procedure), "E100" will appear after a certain period of time and the sewing machine will be forcibly prevented from operating for safety reasons. If this happens, apply grease and carry out the reset procedure.

* If you continue to use the sewing machine after carrying out the reset procedure but without applying grease, problems with the sewing machine may result.

<Applying grease>

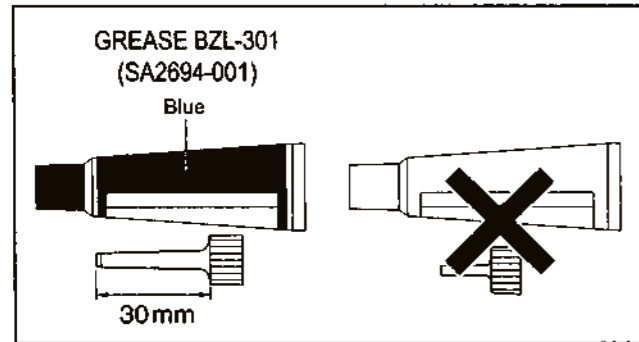

Note:

- Use only the grease <BZL-301 (SA2694-001) in the blue tube> specified by Supreme.
- Do not use the BZL-300 (SA2355-001) grease in the white tube with this sewing machine.
- Do not use the BZL-301 (SA2694-001) grease in the blue tube for any models except for those which are indicated with "Use only the grease <BZL-301 (SA2694-001)> specified by Brother".

Purchase the "grease unit" (SA2693-001) to use for applying grease.

1. Using the tube

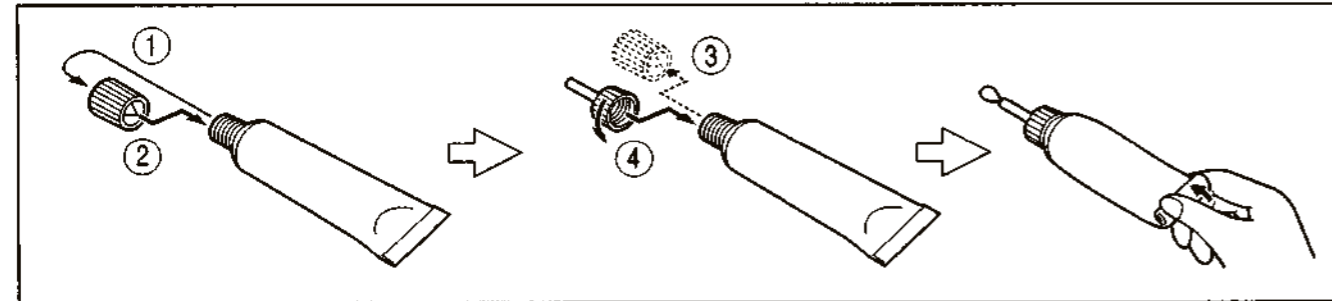

2. Applying grease

Follow the procedure below to apply grease to the places indicated by arrows on the separate page.

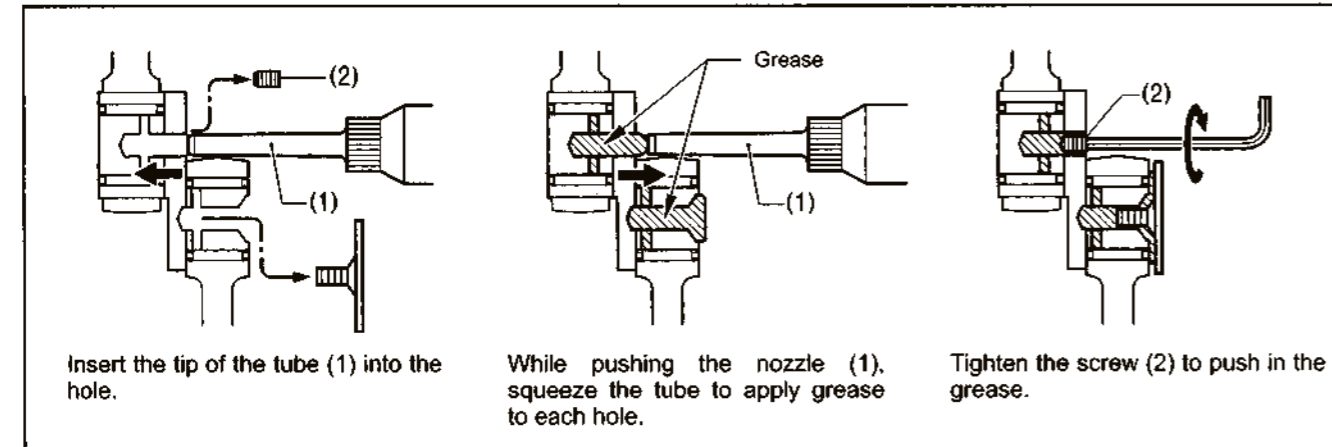

1. Turn off the power switch.
2. Remove the screw (2). (Refer to the separate page for greasing locations.)
3. While turning the machine pulley by hand to move the needle bar up and down, apply grease to each hole until the grease overflows slightly.
4. Tighten the screw (2) to push in the grease.

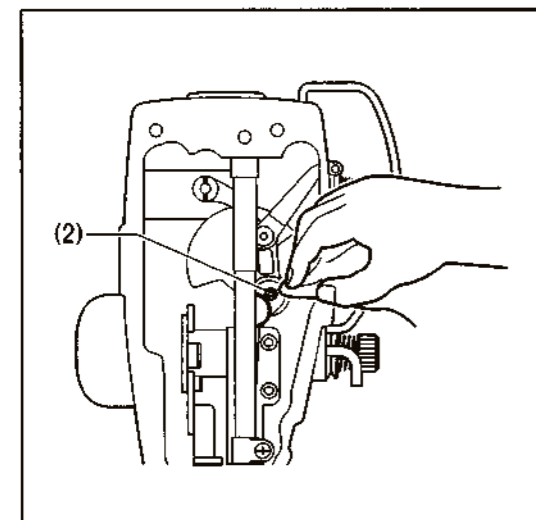

5. Turn the machine pulley by hand to move the needle bar up and down several times in order to disperse the grease.
6. Use a cloth to wipe away any excess grease from around the screw (2).
7. Apply grease to all locations shown on the separate page in the same way.
8. After this, carry out the reset procedure given on the separate page.

Note:

- Once the grease tube has been opened, remove the nozzle from the tube, attach the cap securely and store the tube in a cool dark place.
- The grease should be used as quickly as possible.
- When using the grease again, remove any old grease from inside the nozzle first.

(Store the tube away carefully once the tube has been opened, otherwise the grease remaining inside the tube may deteriorate, and this may affect its lubricating performance.)

9. TABLE OF ERROR CODES

⚠ DANGER



Wait at least 5 minutes after turning off the power switch and disconnecting the power cord from the wall outlet before opening the face plate of the control box. Touching areas where high voltages are present can result in severe injury.

If a malfunction should occur with the sewing machine, a buzzer will sound and an error code will appear in the display window. Follow the remedy procedure to eliminate the cause of the problem.

Switch-related errors

Code	Cause and remedy
E025	Foot switch is depressed to the 2nd step. Turn off the power and check the foot switch.
E035	Foot switch is depressed to the 1st step. Turn off the power and check the foot switch.
E050 E051 E055	Foot switch was pressed or the operation panel was used while the machine head was tilted back, or the machine head was tilted back while it was operating. Turn off the power, and then return the machine head to its original position. Check that connector P8 on the main P.C. board is properly connected.
E065	A switch on the operation panel was being pressed down when the power was turned on, or a switch is faulty. Turn off the power and check the operation panel.

Upper shaft motor-related errors

Code	Cause and remedy
E100	Sewing machine has continued to be used for a certain period after the "GREASEUP" notification appears without the grease being applied (without the reset procedure being carried out). Apply grease and then carry out the reset procedure. (Refer to the service manual for the reset procedure.)
E110	Needle up stop position error. Turn the pulley to align the index mark with the needle up stop position.
E121	Thread trimming was not completed. Turn off the power, and then check if the cutting edges of the fixed knife and movable knife are damaged or worn.
E130	Problem with machine motor stopping, or synchronizer connection error. Turn off the power, and then turn the machine pulley to check if the machine has locked up. Check that connectors P4 and P5 on the power supply motor P.C. board are properly connected.

Feed mechanism-related errors

Code	Cause and remedy
E200	X feed motor home position cannot be detected. Problem with X feed motor or poor X home position sensor connection. Turn off the power, and then check that connector P10 on the PMD P.C. board and connector P2 on the main P.C. board are properly connected.
E201	X feed motor stopped abnormally. Turn off the power and check that there is no problem with the X feed direction.
E202	Problem with X feed motor or Y feed motor home position adjustment data. Re-adjust the home position.
E210	Y feed motor home position cannot be detected. Problem with Y feed motor or poor Y home position sensor connection. Turn off the power, and then check that connector P8 on the PMD P.C. board and connector P3 on the main P.C. board are properly connected.
E211	Y feed motor stopped abnormally. Turn off the power and check that there is no problem with the Y feed direction.

9. TABLE OF ERROR CODES

Work clamp-related errors

Code	Cause and remedy
E300	Work clamp home position cannot be detected. Problem with work clamp motor or poor work clamp home position sensor connection Turn off the power, and then check that connector P3 on the PMD P.C. board and connector P4 on the main P.C. board are properly connected.
E301	Work clamp raised or lowered position cannot be detected. Turn off the power, and check that there is no problem with the vertical work clamp position.

Communication and memory-related errors

Code	Cause and remedy
E450	Model selection has not been loaded from the machine head memory. Turn off the power and check that connector P3 on the power supply motor P.C. board is properly connected.

Data editing-related errors

Code	Cause and remedy
E500	The enlargement ratio setting caused the sewing data to extend outside the sewing area. Set the enlargement ratio again.
E501	Sewing data that exceeds the sewing machine's sewing area was loaded. Check the size of the sewing data.
E502	The enlargement ratio caused the data pitch to exceed the maximum pitch of 12.7 mm. Set the enlargement ratio again.
E530	Changing program number is prohibited.

Device-related errors

Code	Cause and remedy
E690	Thread nipper home position error. Turn off the power, and then clean underneath the needle plate to remove any dust and thread scraps. Check that connector P12 on the main P.C. board is properly connected.
E691	Thread nipper retract position error. Check if the upper thread trailing length is too long. Turn off the power, and then clean underneath the needle plate to remove any dust and thread scraps. Check that connector P12 on the main P.C. board is properly connected.

P.C. board-related errors

Code	Cause and remedy
E700	Abnormal rise in power supply voltage. Turn off the power and check the input voltage.
E705	Abnormal drop in power supply voltage. Turn off the power and check the input voltage.
E740	Cooling fan does not operate. Turn off the power, and then check if the cooling fan is blocked with scraps of thread. Check that connector P18 on the main P.C. board is properly connected.

If an error code that is not listed above appears, contact the place of purchase.

直接驱动式电脑平缝打结机

直接驱动式电脑平缝钉扣机

非常感谢您购买工业缝纫机。在使用缝纫机之前，请仔细阅读<为了您的安全使用>和使用说明书。

工业缝纫机的特性之一，因为要在机针和挑线杆等运动另部件附近进行作业，而这些另部件很容易引起受伤的危险，所以请在受过培训的人或熟练人员的安全操作知识的指导下，正确地使用本缝纫机。

为了您的安全使用

1. 安全使用的标记及其意义

本使用说明书及产品所使用的标记和图案记号是为了您的安全而正确地使用产品，防止您及其他人受到危害和损害。表示方法及含意如下。

说明



危险

如果忽视此标记而进行了错误的操作，必将导致死亡或重伤。



注意

如果忽视此标记而进行了错误的操作，有可能会引起人员受伤及造成设备损坏。

图案和符号



该符号 (△) 表示“应注意事项”。
三角中的图案表示必须要注意的实质内容。
(例如，左边的符号表示“当心受伤”。)











































该符号 (⊘) 表示“禁止”。



该符号 (●) 表示“必须”。
圆圈中的图案表示必须要做的事情的实质内容。
(例如，左边的符号表示“必须接地”。)

2. 安全注意事项

 危险	
<p> 在关闭电源开关并将电源插头从插座上拔下后,至少等待 5 分钟,再打开控制箱盖。触摸带有高电压的区域将会造成人员伤亡。</p>	
 注意	
使用环境	
<p> 应避免在强电气干扰源（如高频焊机）的附近使用本缝纫机。 强电气干扰源可能会影响缝纫机的正确操作。</p> <p> 电源电压的波动应该在额定电压的±10% 以内的环境下使用。 电压大幅度的波动会影响缝纫机的正确操作。</p> <p> 电源容量应大于缝纫机的消耗电量。 电源容量不足会影响缝纫机的正确操作。</p>	<p> 环境温度应在 5℃ ~35℃ 的范围内使用。 低温或高温会影响缝纫机的正确操作。</p> <p> 相对湿度应在 45% ~85% 的范围内,并且设备内不会形成结露的环境下使用。干燥或多湿的环境和结露会影响缝纫机的正确操作。</p> <p> 使用时应避免暴露于直射的阳光下。 直射的阳光下可能会影响正确操作。</p> <p> 万一发生雷电暴风雨时,关闭电源开关,并将电源插头从插座上拔下。 雷电可能会影响缝纫机的正确操作。</p>
安 装	
<p> 请让受过培训的技术人员来安装缝纫机。</p> <p> 请委托购买商店或电气专业人员进行电气配线。</p> <p> 缝纫机重约 56Kg, 安装工作必须由两人以上来完成。</p> <p> 在安装完成前,请不要连接电源,如果误踩脚开关,缝纫机动作会导致受伤。</p> <p> 缝纫机头倒下或竖起时,请用双手进行操作。 另外在头倒下的状态下,在台板处或手轮处不要用力压。缝纫机滑落是造成受伤或缝纫机损坏的原因。</p> <p> 必须接地。接驳地线不牢固,是造成触电或误动作的原因。</p>	<p> 所有电缆应固定在离活动部件至少 25mm 以外处。另外,不要过度弯曲电缆或用卡钉固定得过紧,会引起火灾或触电的危险。</p> <p> 请在机头及马达上安装安全罩壳。</p> <p> 如果使用带小脚轮的工作台,则应该固定小脚轮,使其不能移动。</p> <p> 使用润滑油和黄油时,务必戴好护眼镜和保护手套等,以防润滑油落入眼中或沾在皮肤上,这是引起发炎的原因。 另外,润滑油或黄油不能饮用,否则会引起呕吐和腹泻。 将油放在小孩拿不到的地方。</p>

 注意	
缝 纫	
<p> 本缝纫机仅限于接受过安全操作培训的人员使用。</p> <p> 本缝纫机不能用于除缝纫外的任何其他用途。</p> <p> 使用本缝纫机时必须戴上护眼镜。 如果不戴护眼镜,断针时就会有危险,机针的折断部分可能会弹入眼睛并造成伤害。</p> <p> 发生下列情况时,请切断电源。当误踩脚开关时,缝纫机动作会导致受伤。</p> <ul style="list-style-type: none"> · 机针穿线时 · 更换机针或梭芯时 · 缝纫机不使用,或人离开缝纫机时。 <p> 如果使用带小脚轮的工作台,则应该固定小脚轮,使其不能移动。</p>	<p> 为了安全起见,在使用本缝纫机之前,请安装保护装置。如果未安装这些安全装置就使用缝纫机,会造成人身伤害及缝纫机损坏。</p> <p> 缝纫过程中不要触摸任何活动部件或将物件靠在运动部件上,因为这会导致受伤或缝纫机损坏。</p> <p> 如果缝纫机操作中发生误动作,或者如果听到异常的噪声或闻到异常的气味,应立即切断电源。然后请与购买商店或受过培训的技术人员联系。</p> <p> 如果缝纫机出现故障时,请与购买商店或受过培训的技术人员联系。</p>
清 洁	
<p> 在开始清洁作业前,请切断电源。如果误踩了脚开关,缝纫机动作会导致人员受伤。</p>	<p> 使用润滑油和黄油时,务必戴好护眼镜和保护手套等,以防润滑油落入眼中或沾在皮肤上,这是引起发炎的原因。 另外,润滑油或黄油不能饮用,否则会引起呕吐和腹泻。 将油放在小孩拿不到的地方。</p>
维 护 和 检 查	
<p> 只有经过训练的技术人员才能进行缝纫机的维修、保养和检查。</p> <p> 与电气有关的维修、保养和检查请委托购买商店或电气专业人员进行。</p> <p> 发生下列情况时,请关闭电源,并拔下电源线插座。否则误踩下脚开关时,缝纫机动作会导致受伤。</p> <ul style="list-style-type: none"> · 检查、调整和维修 · 更换旋梭等消耗零部件 	<p> 在必须接上电源开关进行调整时,务必十分小心遵守所有的安全注意事项。</p> <p> 缝纫机头倒下或竖起时,请用双手进行操作。 另外在头倒下的状态下,在台板处或手轮处不要用力压。缝纫机滑落是造成受伤或缝纫机损坏的原因。</p> <p> 请使用本工业公司指定的更换零部件。</p> <p> 取下的安全保护装置,再次安装时,请务必安装在原位上,并检查能否正确地操作。</p> <p> 未经授权而对缝纫机进行改装而引起的缝纫机损坏不在保修范围内。</p>

3. 警告标签

缝纫机上有下列警告标签。

当使用缝纫机时，请遵守标签上的说明。如果标签脱落或模糊不清，请和购买商店联系。

1

	⚠ DANGER	⚠ 危险
	Hazardous voltage will cause injury. Turn off main switch and wait 5 minutes before opening this cover.	触摸高压电部分，会导致受伤。在切断电源5分钟后，再开启盖罩。

2

⚠ 注意
触摸运动部分，易造成受伤。所以在装上安全保护装置后，再进行缝纫操作。在切断电源后，进行穿线、更换梭芯、机针和做清扫、调整工作。
⚠ CAUTION
Moving parts may cause injury. Operate with safety devices. Turn off main switch before threading, changing bobbin and needle, cleaning etc.

3

PE 必须保证接地。如果接地不可靠，很有可能受到严重电击，操作也可能出现问题。

4

表示转动方向

安全保护装置
护眼板，护指器，松线电磁铁盖，挑线杆防护罩，侧盖，后盖

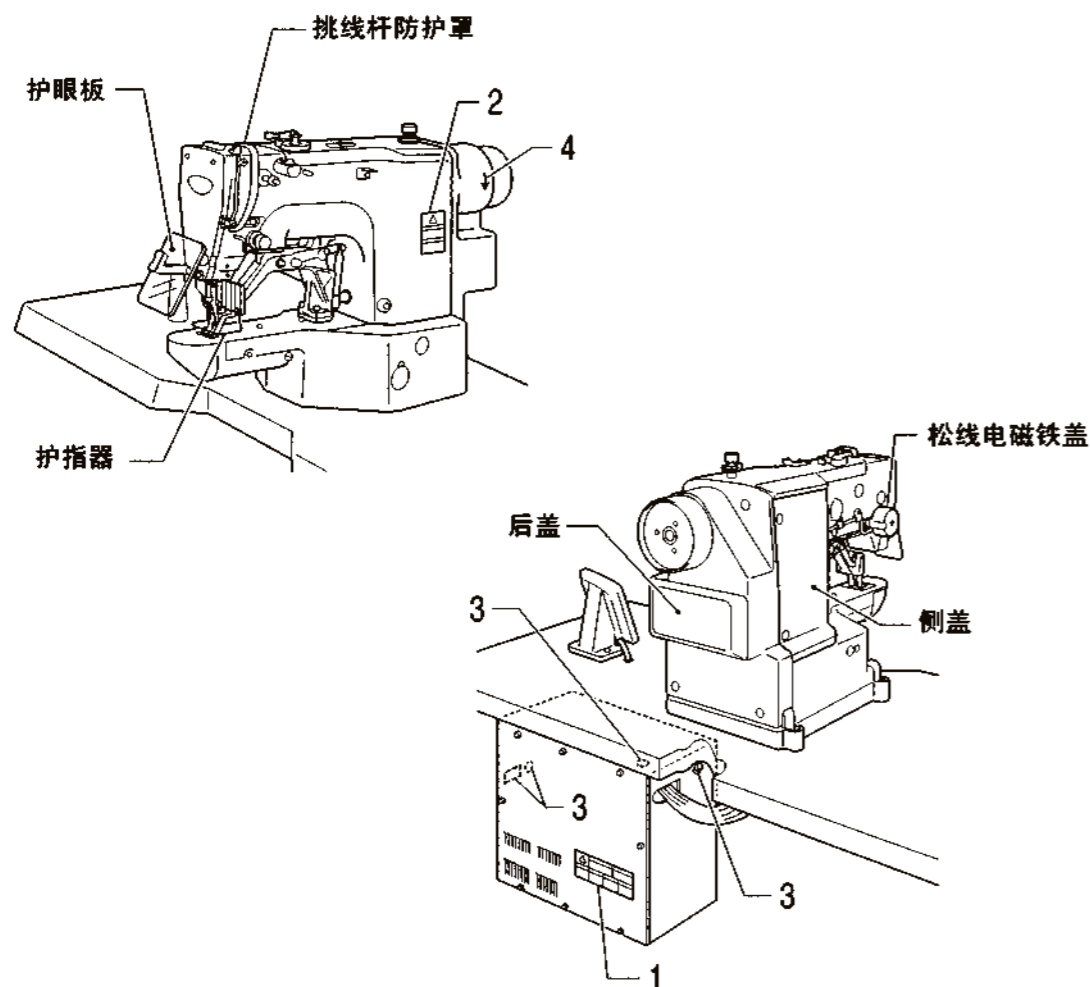

目 录

1. 各部件名称	1	5. 操作盘的使用方法（基本操作）	29
2. 规格	2	5-1. 每个操作盘部件的名称和功能	29
2-1. 缝纫机规格	2	5-2. 程序号的设置方法	31
2-2. 预设图案表 (CSM-430D)	3	5-3. 横向倍率/纵向倍率的设置方法	31
2-3. 预设图案表 (CSM-438D)	8	5-4. 缝纫速度的设置方法	31
3. 安装方法	11	5-5. 缝纫图案的确认 (CSM-430D)	32
3-1. 台板加工图	11	5-6. 缝纫图案的确认 (CSM-438D)	33
3-2. 安装控制箱	12	5-7. 压脚/钮扣夹上升量的设置	34
3-3. 安装油盘	12	6. 操作盘的使用方法（上级操作）	35
3-4. 安装缝纫机头部	13	6-1. 实用功能一览	35
3-5. 安装操作盘	14	6-2. 存储器开关的设置方法	36
3-6. 安装脚踏用复合件	14	6-3. 存储器开关一览表	37
3-7. 安装线架	15	6-4. 底线计数器的使用方法	38
3-8. 安装钮扣盘 (CSM-438D)	15	6-5. 生产量计数器的使用方法	39
3-9. 安装护眼板	15	6-6. 用户程序的使用方法	40
3-10. 连接线缆	16	6-7. 循环程序的使用方法	43
3-11. 地线的连接	18	6-8. 直接选择的方法	46
3-12. 安装后盖	18	6-9. 追加缝纫数据的读取方法	46
3-13. 加油	19	7. 缝纫	47
3-14. 启动	20	8. 保养	48
4. 缝纫前的准备	21	8-1. 旋梭的清洁	48
4-1. 机针的安装方法	21	8-2. 控制箱进气口的清洁	49
4-2. 面线的穿法	21	8-3. 更换润滑油	49
4-3. 底线的绕线方法	23	8-4. 护眼板的清洁	49
4-4. 梭芯套的装取方法	24	8-5. 机针的检查	49
4-5. 夹线器张力	24	8-6. 加油	49
4-5-1. 底线的张力	24	8-7. 添加润滑脂（当出现“GREASEUP”时）	50
4-5-2. 面线的张力	25	9. 误码表	52
4-6. 夹线装置	26		
4-7. 钮扣的插入方法 (CSM-438D)	28		
4-8. 钮扣夹的调节 (CSM-438D)	28		
4-9. 钮扣上浮弹簧（随带）的安装方法 (CSM-438D)	28		

1. 各部件名称

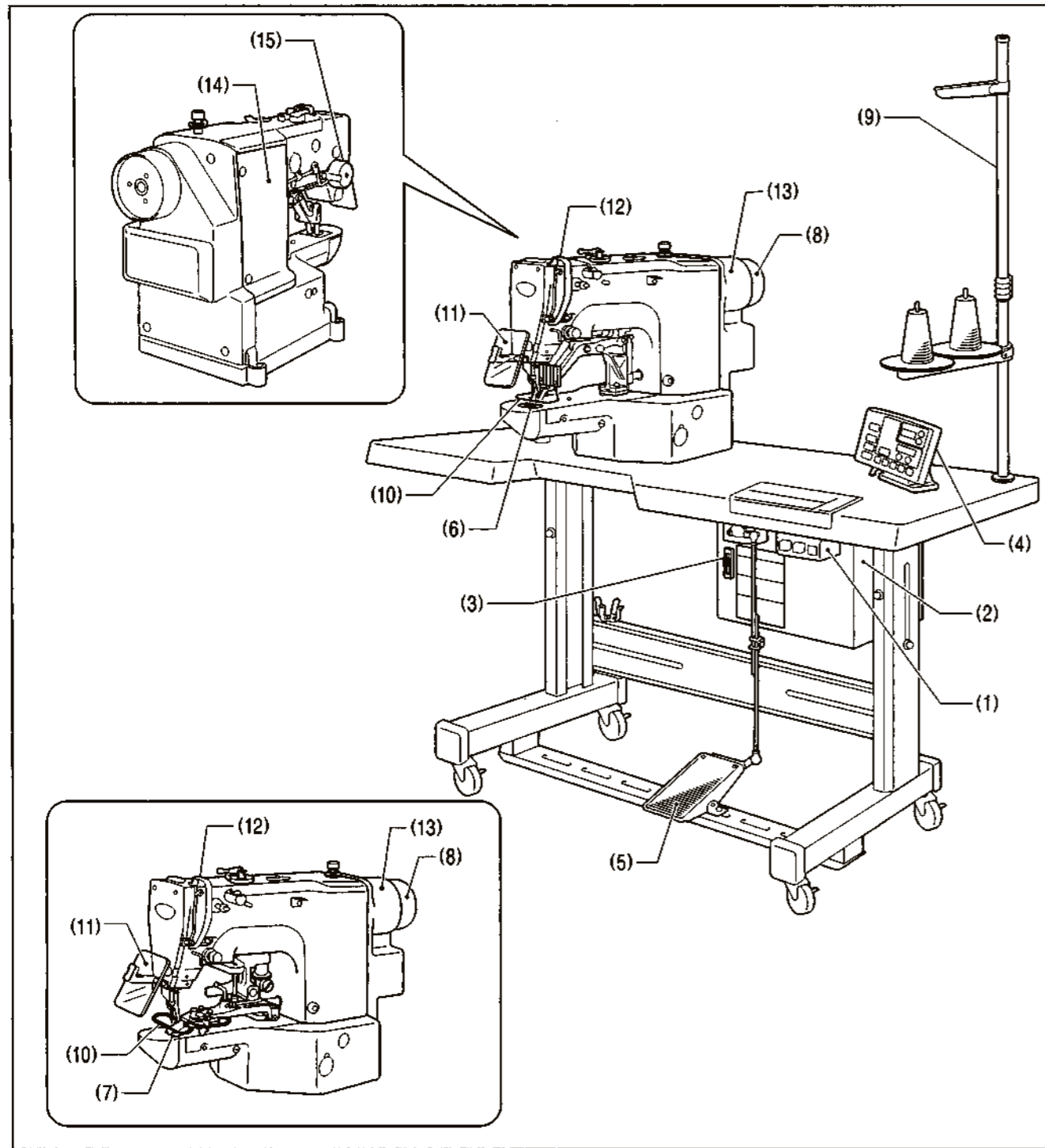

- (1) 电源开关
 (2) 控制箱
 (3) CF 卡插入口
 (4) 操作盘
 (5) 脚踏开关
 (6) 压脚 (CSM-430D)
 (7) 钮夹 (CSM-438D)
 (8) 皮带轮
 (9) 线架

安全保护装置

- (10) 护指器
 (11) 护眼板
 (12) 挑线杆防护罩
 (13) 后盖
 (14) 侧盖
 (15) 松线电磁铁盖

2. 规格

2-1. 缝纫机规格

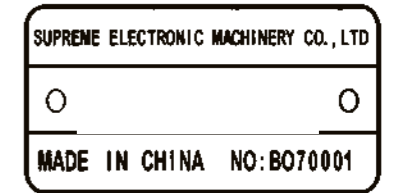
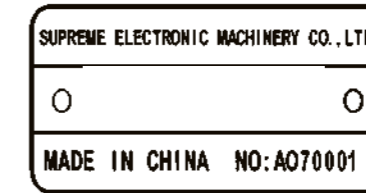
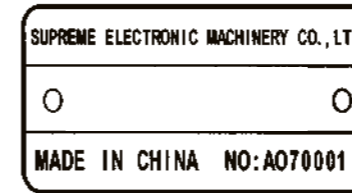

	直接驱动式电脑平缝打结机	直接驱动式电脑平缝钉扣机
线迹形式	单针平缝	
最高缝纫速度	3,200rpm	2,700rpm
尺寸 (X × Y)	最大 40 × 30 mm	最大 6.4 × 6.4 mm
缝纫钮扣的尺寸		钮扣外径 8 ~ 30mm (对于直径为 20-30mm 的使用可选钮扣夹)
送布驱动方式	Y-θ 间歇送布 (脉冲马达驱动)	
针距	0.05 ~ 12.7mm	
针数	可变 (关于已输入的缝纫图案的针数, 请参照“预设图案表”)	
最大针数	210,000 针 (包括可加的 200,000 针)	
抬压脚驱动方式	脉冲马达驱动	
压脚上升量	最大 17mm	最大 13mm
钮扣夹上升量		
使用的旋梭	标准半转旋梭 (双倍旋梭另售)	标准半转旋梭
扫线装置	标准装备	
切线装置	标准装备	
夹线装置	标准装备	
数据存储方式	快擦写存储器 (使用 CF 卡可以追加任意种缝纫图案)	
用户程序数	50	
循环程序数	9	
存储数据数	已设置 89 种缝纫图案	已设置 49 种缝纫图案
	(最多可增加 200 种图案。追加总针数在 200,000 针以内。)	
马达	AC 伺服马达 550W	
重量	头部: 约 56kg, 操作盘: 约 0.6kg 控制箱: 14.2 ~ 16.2kg (根据电压不同而不同)	
电源	单相 100V / 220V, 3 相 200V / 220V / 380V / 400V 400VA	

2-2. 预设图案表

下表所示的程序已预先设置好，可以根据规格予以选择使用。（只要能够确认是在压脚、送布板的工作范围内，就可以选择、使用任一种缝纫图案。）

请使用符合各种缝纫图案要求的压脚和送布板。

缝纫尺寸为 100% 缩放率时的长度。

用于普通布料 (-01)									
号码	缝纫图案	针数	尺寸 (mm)		号码	缝纫图案	针数	尺寸 (mm)	
			长度	宽度				长度	宽度
1		42	16	2	65		43	16	2
4		31	16	2	66		32	16	2
5		29	10	2	67		30	10	2
8		21	7	2	68		22	7	2
13		35	10	2	69		36	10	2
15		42	10	2	70		43	10	2
20		28	7	2	71		29	7	2
21		35	7	2	72		36	7	2
64		30	16	2	89		90	24	3









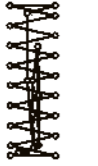

用于劳动布 (-02)									
号码	缝纫图案	针数	尺寸 (mm)		号码	缝纫图案	针数	尺寸 (mm)	
			长度	宽度				长度	宽度
2		42	20	3	18		56	24	3
3		35	20	3	19		64	24	3
6		30	16	3	62		42	20	3
14		35	16	3	63		35	20	3
16		43	16	3	78		43	20	3
17		42	24	3	79		36	20	3



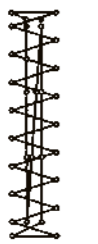

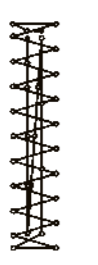

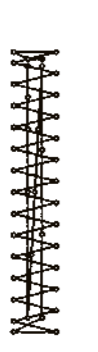
用于劳动布 (-02)									
号码	缝纫图案	针数	尺寸 (mm)		号码	缝纫图案	针数	尺寸 (mm)	
			长度	宽度				长度	宽度
80		31	16	3	83		43	24	3
81		36	16	3	84		57	24	3
82		44	16	3	85		65	24	3

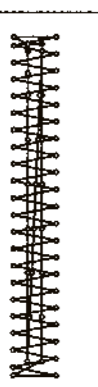

用于女性内衣 (-07)									
号码	缝纫图案	针数	尺寸 (mm)		号码	缝纫图案	针数	尺寸 (mm)	
			长度	宽度				长度	宽度
7		28	8	2	73		29	8	2
9		21	7	2	74		22	7	2
22		14	7	2	75		15	7	2
31*		28	8	2	76*		29	8	2
32*		22	8	2	77*		23	8	2
33*		15	8	2					

* 始针和终结针的位置在图案的中间。

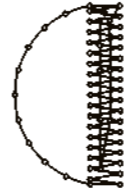
直线结					垂直曲折缝				
号码	缝纫图案	针数	尺寸 (mm)		号码	缝纫图案	针数	尺寸 (mm)	
			长度	宽度				长度	宽度
10		21	10	0.3	44		46	9	15
11		28	10	0.3					
12		28	20	0.3					
23		35	25	0.3					
24		42	25	0.3					
25		45	25	0.3					

垂直结					垂直直线结				
号码	缝纫图案	针数	尺寸 (mm)		号码	缝纫图案	针数	尺寸 (mm)	
			长度	宽度				长度	宽度
26		28	3	10	28		19	0.3	10
27		35	3	10	29		21	0.3	10
40		32	3	16	30		28	0.3	10
41		36	3	16	46		27	0.3	20
42		44	3	20	47		44	0.3	25
43		68	3	24					

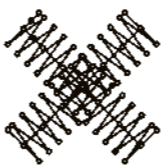
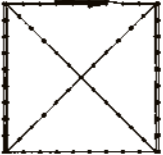
月牙结									
号码	缝纫图案	针数	尺寸 (mm)		号码	缝纫图案	针数	尺寸 (mm)	
			长度	宽度				长度	宽度
34		35	12	7	37		57	7	12
35		58	12	7	38		53	7	10
36		57	7	12	39		53	7	10

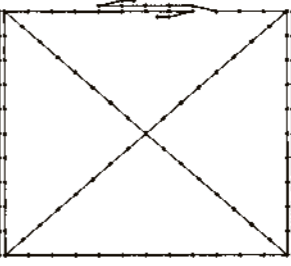
X形结					交叉结				
号码	缝纫图案	针数	尺寸 (mm)		号码	缝纫图案	针数	尺寸 (mm)	
			长度	宽度				长度	宽度
48		70	10	10	50		84	16	16
49		93	9.6	9.6	51		105	30	26

L形结									
号码	缝纫图案	针数	尺寸 (mm)		号码	缝纫图案	□数	尺寸 (mm)	
			长度	宽度				长度	宽度
52		60	11.3	11.2	53		60	11.3	11.2
54		78	15.3	15.2	55		78	15.3	15.2
菊形缝									
号码	缝纫图案	针数	尺寸 (mm)		号码	缝纫图案	针数	尺寸 (mm)	
			长度	宽度				长度	宽度
56		106	9	9	59		104	10	10
57		116	9	9	60		114	10	10
58		127	9	9	61		124	10	10
圆眼钮孔									
号码	缝纫图案	针数	尺寸 (mm)						
			长度	宽度					
86		21	6	2					
87		28	6	2					
88		35	6	2					

如果想缝纫除了标准图案以外的其他图案,可以使用 BAS-PC/300 创造原始图案。详情请咨询当地的销售办事处。

作成追加数据 (程序号 200~999) 时的注意事项

如果反复缝纫 (短循环运转) 运针数 (15 针以下) 短的缝纫数据, 则可能会引起上轴马达过热 [E150] 的现象。

2-3. 预设图案表 (CSM-438D)

下表所示的程序已预先设置好, 只要能够确认机针落在钮孔内, 就可以选择、使用任一种缝纫图案。
对于没有包缝线的程序, 在完成一边缝纫后就进行剪线, 然后再进行另一边的缝纫。

号码	钮孔数	缝纫图案	线数	包缝数	针数	尺寸 (mm)	
						X	Y
1	2		6	—	12	3.4	0
2			8	—	14		
3			10	—	16		
4			12	—	18		
5 ※1			16	—	22		
6 ※1			20	—	26		
7 ※2	2		6	—	12	0	3.4
23 ※2			10	—	16		
8 ※2			12	—	18		
9 ※2	3		5-5-5	—	21	2.6	2.4
24 ※2			7-7-7	—	27		
25 ※2			5-5-5	—	21		
26 ※2			7-7-7	—	27		
10	4		6-6	1	19	3.4	3.4
11			8-8	1	23		
12			8-8	3	25		
13			10-10	1	27		
27			12-12	1	31		

※1 使用程序前检查钮孔直径为 2mm 或更大。

※2 不可使用钮扣抬起弹簧。

号码	钮孔数	缝纫图案	线数	包缝数	针数	尺寸 (mm)		
						X	Y	
14 ※3	4		6-6	0	24	3.4	3.4	
36 ※4			6-6	0	24			
28 ※3			8-8	0	28			
37 ※4			8-8	0	28			
15 ※3			10-10	0	32			
38 ※4			10-10	0	32			
29 ※3			12-12	0	36			
39 ※4			12-12	0	36			
16				6-5	1			18
17				8-7	1			22
30		10-9		1	26			
18		6-6		1	19			
19			8-8	1	23			
31			10-10	1	27			
45			12-12	1	31			
20 ※3				6-6	0			24
40 ※4		6-6		0	24			
32 ※3		8-8		0	28			
41 ※4		8-8		0	28			
33 ※3		10-10		0	32			
42 ※4	10-10	0		32				

※3 在完成一边缝纫后，钮扣夹就上升并进行拔线动作。为了将缝纫进行到底，在另一边的缝纫开始之前，请继续踩下脚踏开关；或在完成一边缝纫后，请再次踩下脚踏开关。

※4 在完成一边缝纫后，钮扣夹不上升而只进行拔线动作，并继续进行另一边的缝纫。

号码	钮孔数	缝纫图案	线数	包缝数	针数	尺寸 (mm)	
						X	Y
21 ※2	4		6-6	1	19	2.4	3.4
34 ※2			10-10	1	27		
22 ※2※3			6-6	0	24		
43 ※2※4			6-6	0	24		
35 ※2※3			10-10	0	32		
44 ※2※4			10-10	0	32		
46			6-6	1	19	3.4	3.4
47			8-8	1	23		
48			10-10	1	27		
49			12-12	1	31		

※2 不可使用钮扣抬起弹簧。

※3 在完成一边缝纫后，钮扣夹就上升并进行拔线动作。为了将缝纫进行到底，在另一边的缝纫开始之前，请继续踩下脚踏开关；或在完成一边缝纫后，请再次踩下脚踏开关。

※4 在完成一边缝纫后，钮扣夹不上升而只进行拔线动作，并继续进行另一边的缝纫。

作成追加数据 (程序号 200~999) 时的注意事项

如果反复缝纫 (短循环运转) 运针数 (15 针以下) 短的缝纫数据，则可能会引起上轴马达过热 [E150] 的现象。

3. 安装方法

注意

- ⊘ 请让受过培训的技术人员来安装缝纫机。
- ⚠ 请委托购买商店或电气专业人员进行电气配线。
- ⚠ 缝纫机重约 56Kg, 安装工作必须由两人以上来完成。
- ⊘ 在安装完成前, 请不要连接电源, 如果误踩脚开关, 缝纫机动作会导致受伤。
- ⚠ 缝纫机头倒下或竖起时, 请用双手进行操作。另外在头倒下的状态下, 在台板处或手轮处不要用力压。缝纫机滑落是造成受伤或缝纫机损坏的原因。
- ⚠ 所有电缆应固定在离活动部件至少 25mm 以外处。另外, 不要过度弯曲电缆或用卡钉固定得过紧, 会引起火灾或触电的危险。
- ⊘ 必须接地。接驳地线不牢固, 是造成触电或误动作的原因。
- ⚠ 请在机头及马达上安装安全罩壳。

3-1. 台板加工图

- 台板的厚度应达 40mm, 能够承受缝纫机的重量, 并经受起缝纫机的震动。
- 如果机脚的内侧尺寸 A 小于 740mm, 请将控制箱的安装位置 (B=254mm) 移向左侧进行加工。
- 请确认控制箱应离开机脚 10mm 以上。如果控制箱过于靠近机脚, 则可能会引起缝纫机的误动作。

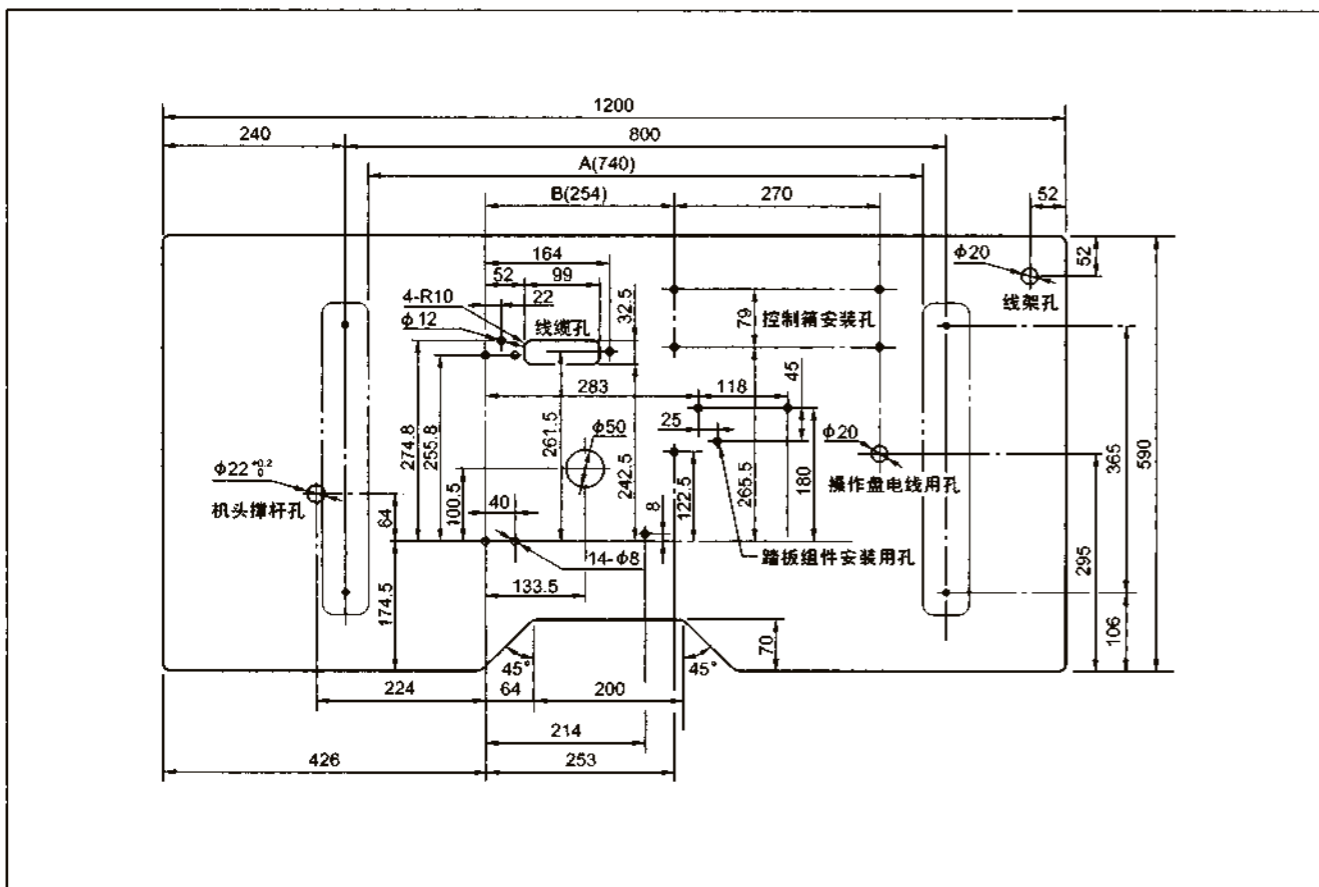

3-2. 安装控制箱

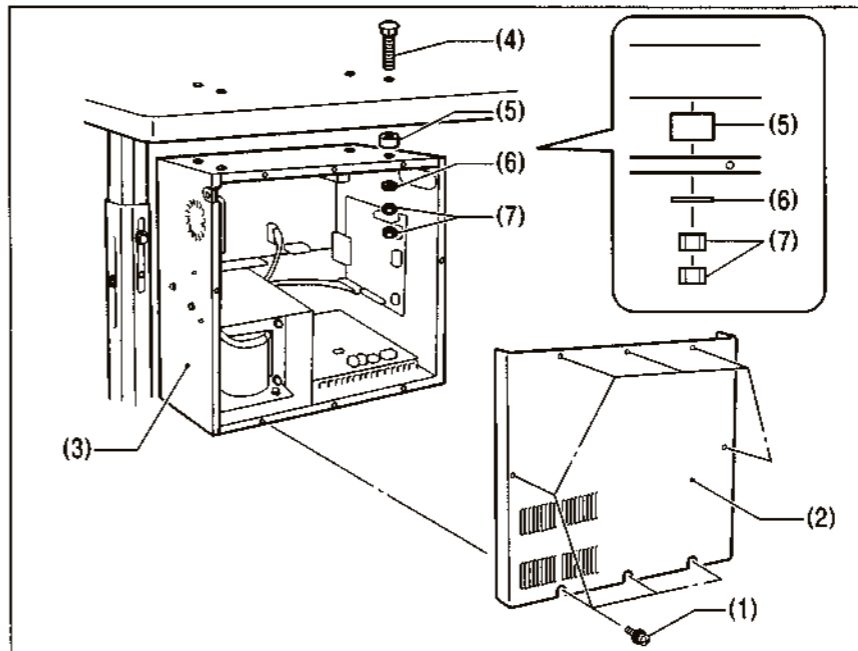

拧下固定螺钉 (1) [8 个], 拆下控制箱的盖子 (2)。

- (3) 控制箱
- (4) 螺栓 [4 个]
- (5) 垫片 [4 个]
- (6) 垫圈 [4 片]
- (7) 螺母 [8 个]

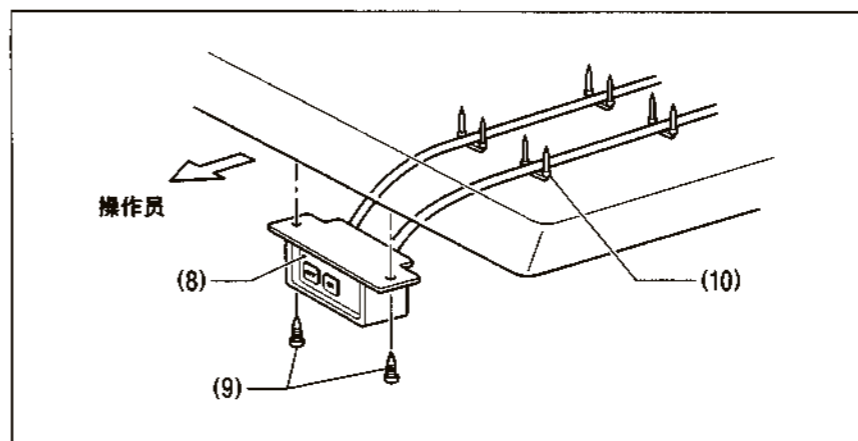

- (8) 电源开关
- (9) 螺钉 [2 个]
- (10) U 形卡钉 [4 个]

3-3. 安装油盘

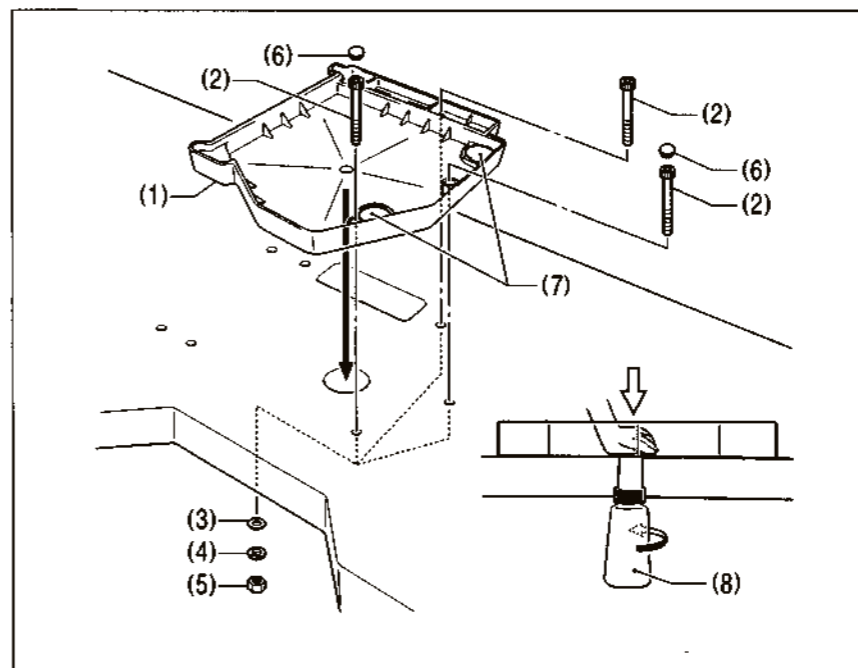

- (1) 油盘
- (2) 螺栓 [3 个]
- (3) 垫圈 [3 片]
- (4) 弹簧垫圈 [3 片]
- (5) 螺母 [3 个]
- (6) 橡皮塞 [2 个]
- (7) 防震橡皮 [2 个]
- (8) 注油器瓶

3-4. 安装缝纫机头部

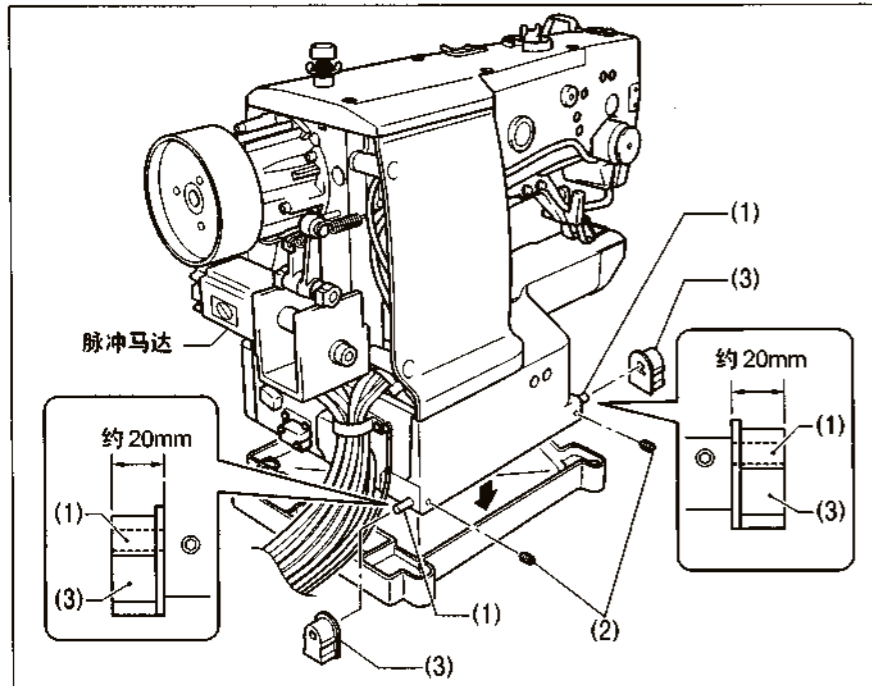

- (1) 机头支撑销 [2个]
- (2) 螺钉 [2个]
- (3) 机头铰链橡皮组 [2个]

将机头轻轻地放在油盘、防震橡皮上。

注意:

- 请注意不要让电线夹在机头和油盘之间。
- 在拿机头时, 请不要握住脉冲马达。否则可能会引起脉冲马达的故障。

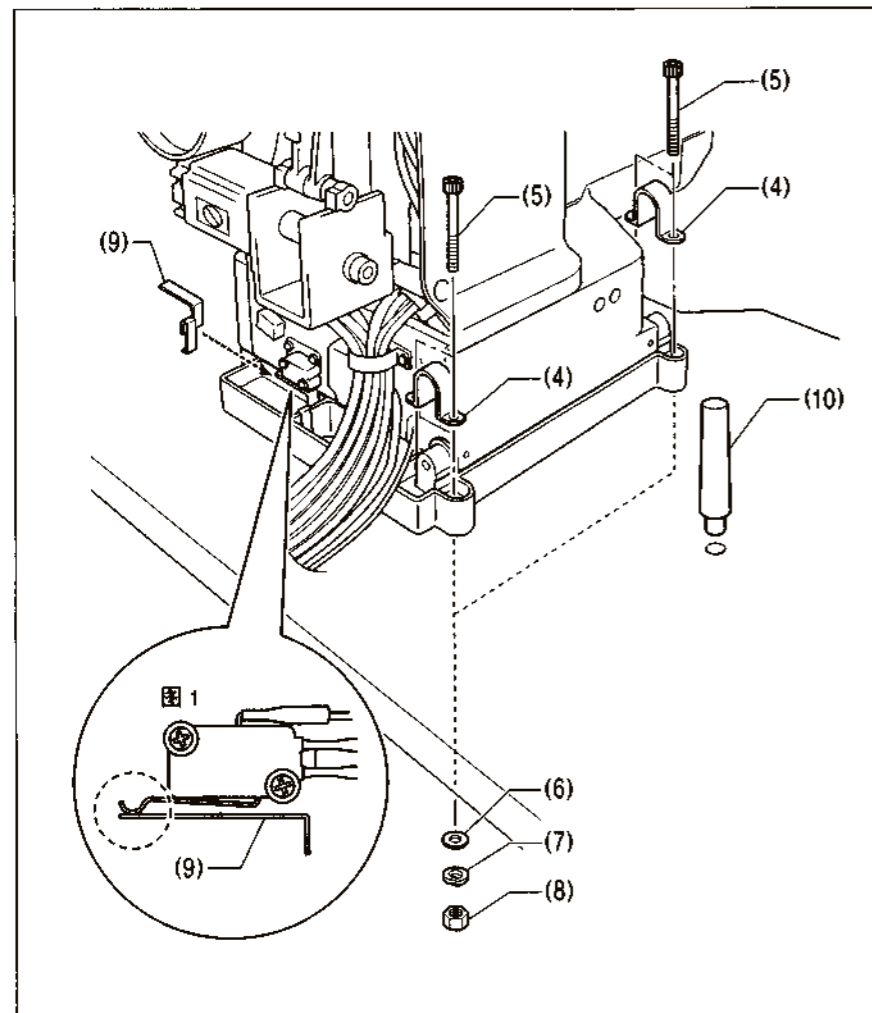

- (4) 机头铰链套 [2个]
- (5) 螺栓 [4个]
- (6) 垫圈 [4片]
- (7) 弹簧垫圈 [4片]
- (8) 螺母 [4个]
- (9) 机头开关弹簧
- (10) 机头撑杆

注意:

- 请确认机头开关已装上, 如图 1 所示。
- 将机头撑杆 (10) 安全、稳定地插入台板开孔。

3-5. 安装操作盘

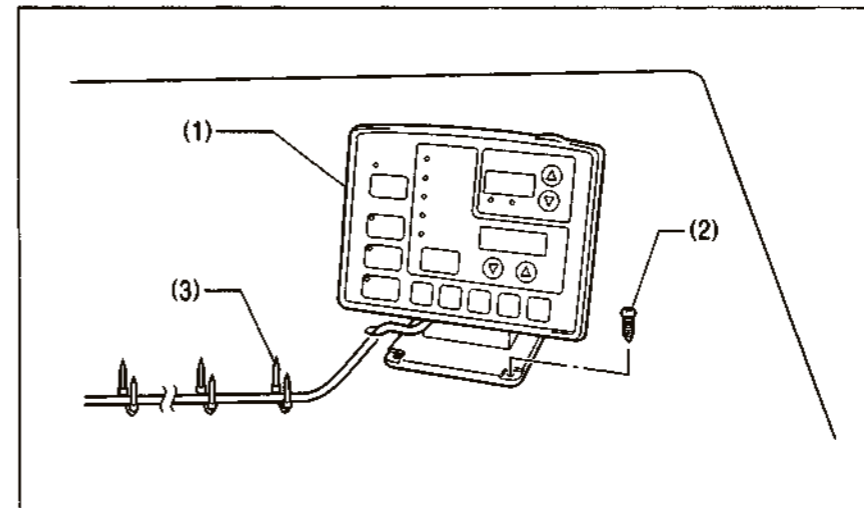

- (1) 操作盘
- (2) 螺钉 [4个]
- 将操作盘的电线穿过台板上的孔, 然后从控制箱侧面的孔引入控制箱内。
- (3) U形卡钉 [3个]

3-6. 安装踏脚用复合件

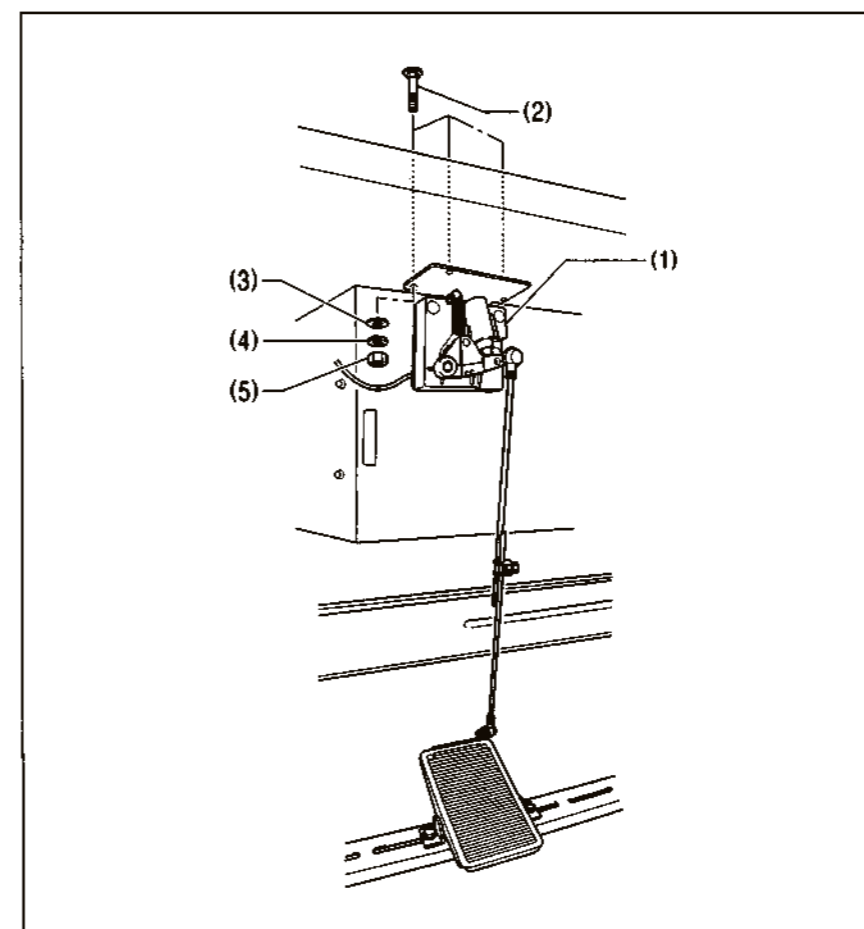

- (1) 踏脚用复合件
- (2) 螺栓 [3个]
- (3) 垫圈 [3片]
- (4) 弹簧垫圈 [3片]
- (5) 螺母 [3个]

※ 脚踏开关和连杆请使用市售商品。

3-7. 安装线架

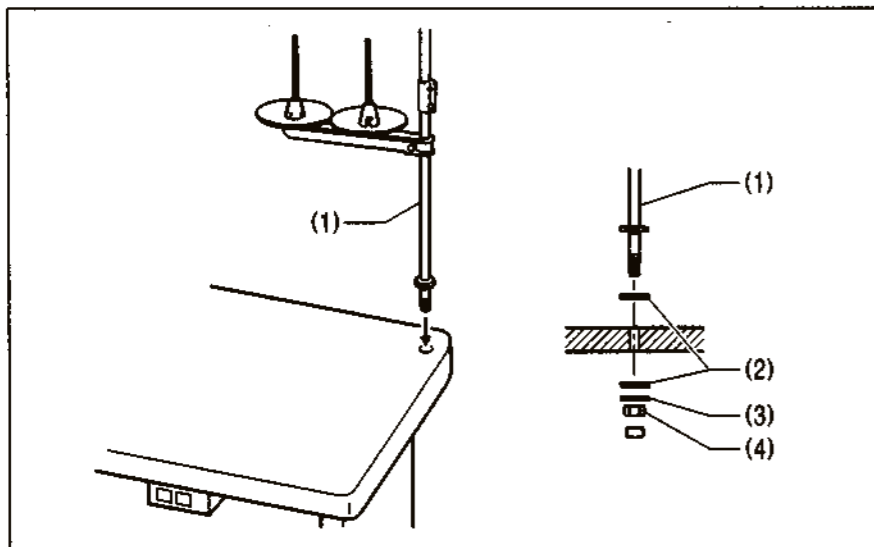

(1) 线架

注意:

将螺母(4)拧紧以便将两个机壳铰链套(2)和垫圈(3)夹紧,使线架(1)不会移动。

3-8. 安装钮扣盘 (CSM-438D)

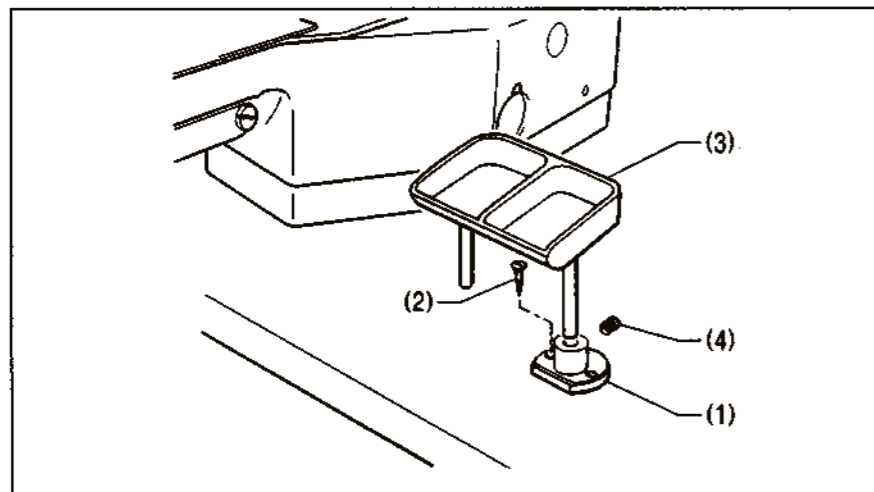

请安装在便于操作的位置。

- (1) 钮扣盘座
- (2) 螺钉 [2个]
- (3) 钮扣盘
- (4) 螺钉

3-9. 安装护眼板

注意

为了安全起见, 在使用本缝纫机之前, 请安装保护装置。
如果未安装这些安全装置就使用缝纫机, 会造成人身伤害及缝纫机损坏。

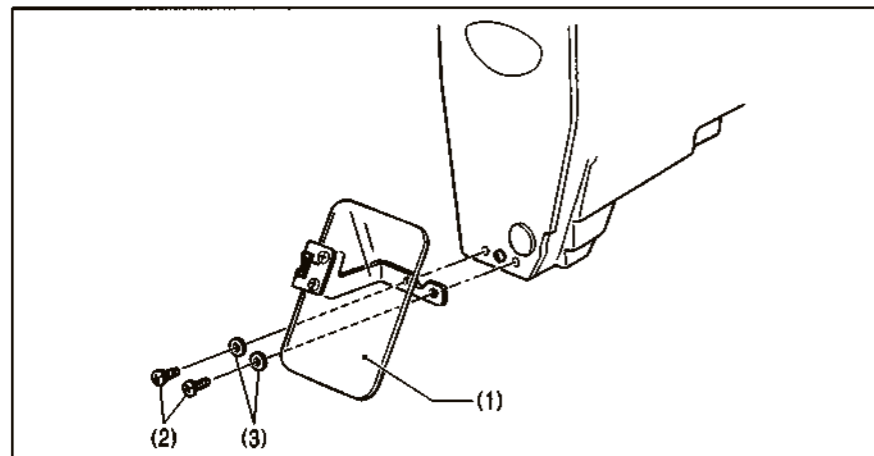

- (1) 护眼板组件
- (2) 螺钉 [2个]
- (3) 垫圈 [2片]

3-10. 连接线缆

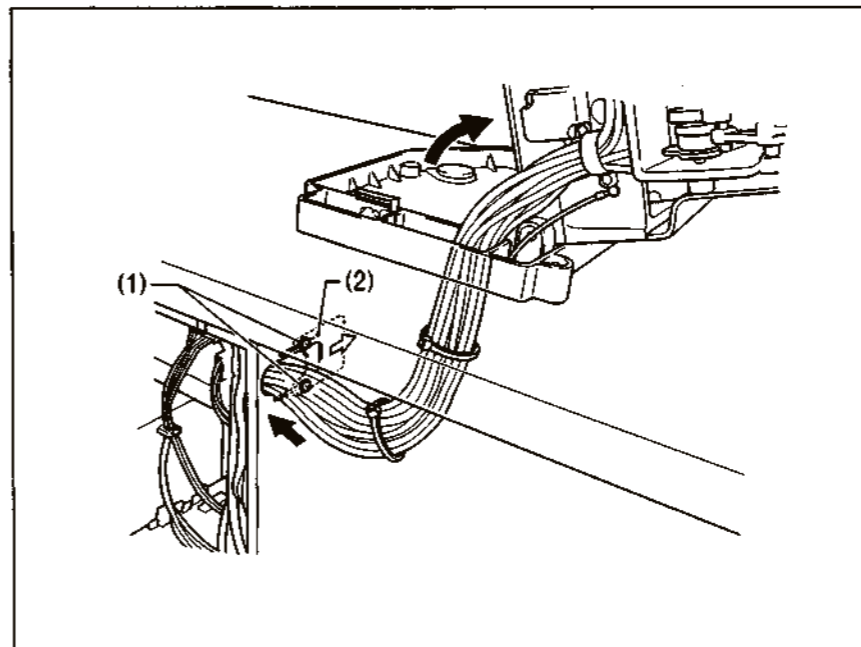

1. 慢慢地将缝纫机头部倒下。
2. 将电线束穿过台板上的孔。
3. 拧松固定螺钉(1) [2个], 使电线压板(2)朝→方向打开, 然后把电线束穿过台板上的孔。
4. 按照下表所示将插头插入。

注意:

- 请注意插头的插入方向, 要一直插到确实锁定为止。
- 用捆线箍带、线夹固定电线, 在固定时应注意不要拉伸插头。

<主基板>

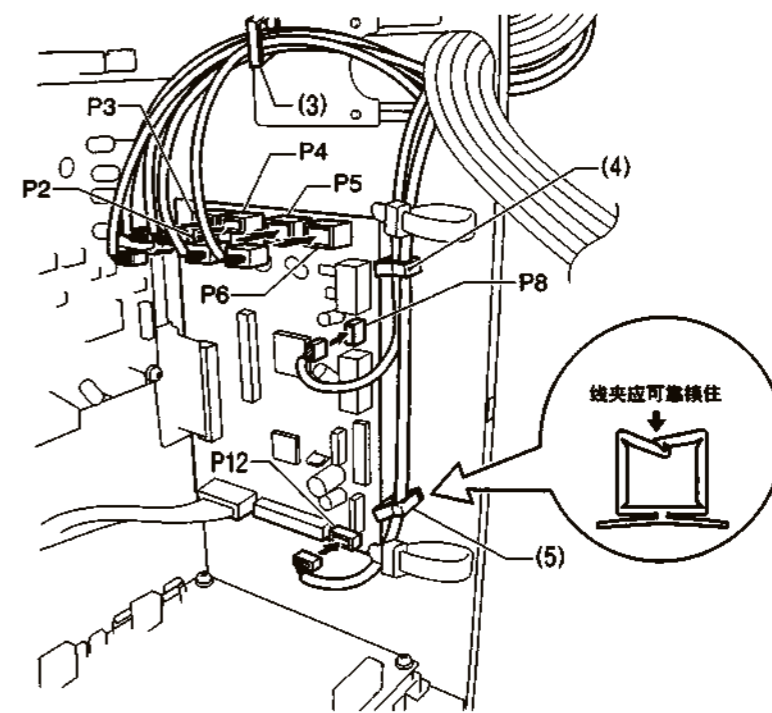

插头	主基板上的表示	线夹
X 脉冲马达编码器 5 插脚 白	P2 (X-ENC)	(3)
Y 脉冲马达编码器 5 插脚 蓝	P3 (Y-ENC)	(3)
压脚编码器 5 插脚	P4 (P-ENC)	(3)
脚踩开关 10 插脚	P5 (FOOT)	(3)
操作盘 8 插脚	P6 (PANEL)	(3)
机头开关 3 插脚	P8 (HEAD-SW)	(4)
夹线感应器 6 插脚	P12 (TPK-SEN)	(4), (5)

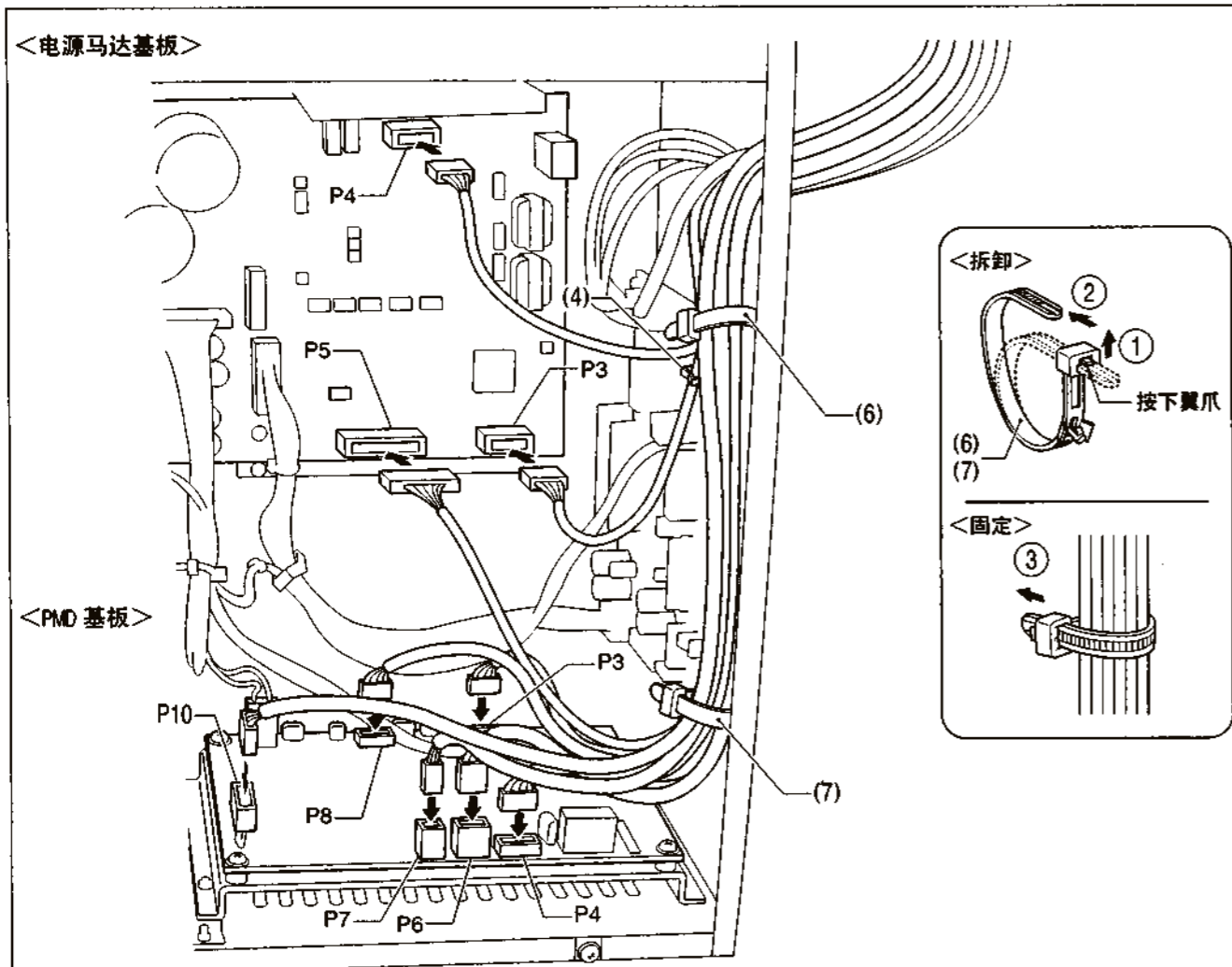

插头	电源马达基板上的显示	线夹
机头存储器 7 插脚	P3 (HEAD-M)	(4)
上轴马达 3 插脚	P4 (UVW)	(6)
同步器 14 插脚	P5 (SYNC)	(6)、(7)
插头	PMD 基板上的显示	线夹
压脚脉冲马达 4 插脚	P3 (PPM)	(6)、(7)
夹线脉冲马达 6 插脚	P4 (BT-PICK)	(6)、(7)
切线电磁铁 6 插脚	P6 (SOL1)	(6)、(7)
松线电磁铁 4 插脚	P7 (SOL2)	(6)、(7)
Y 脉冲马达 蓝	P8 (YPM)	(6)、(7)
X 脉冲马达 4 插脚 白	P10 (XPM)	(6)、(7)

注意：在布排 X、Y、压脚脉冲马达的线束时，不要触碰到 PMD 基板。

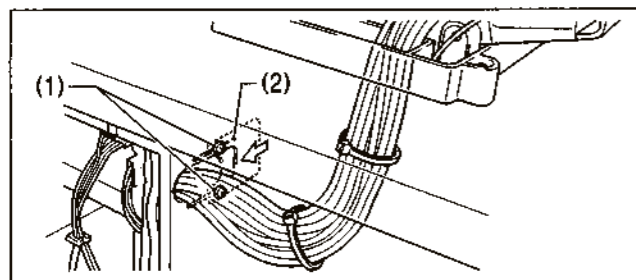

- 朝←方向关闭电线压板 (2)，然后拧紧固定螺钉 (1) [2 个]。
- 确认电线应没有被拉伸，然后慢慢地将机头返回到原位。

3-11. 地线的连接



必须接地。
接驳地线不牢固，是造成触电或误动作的原因。

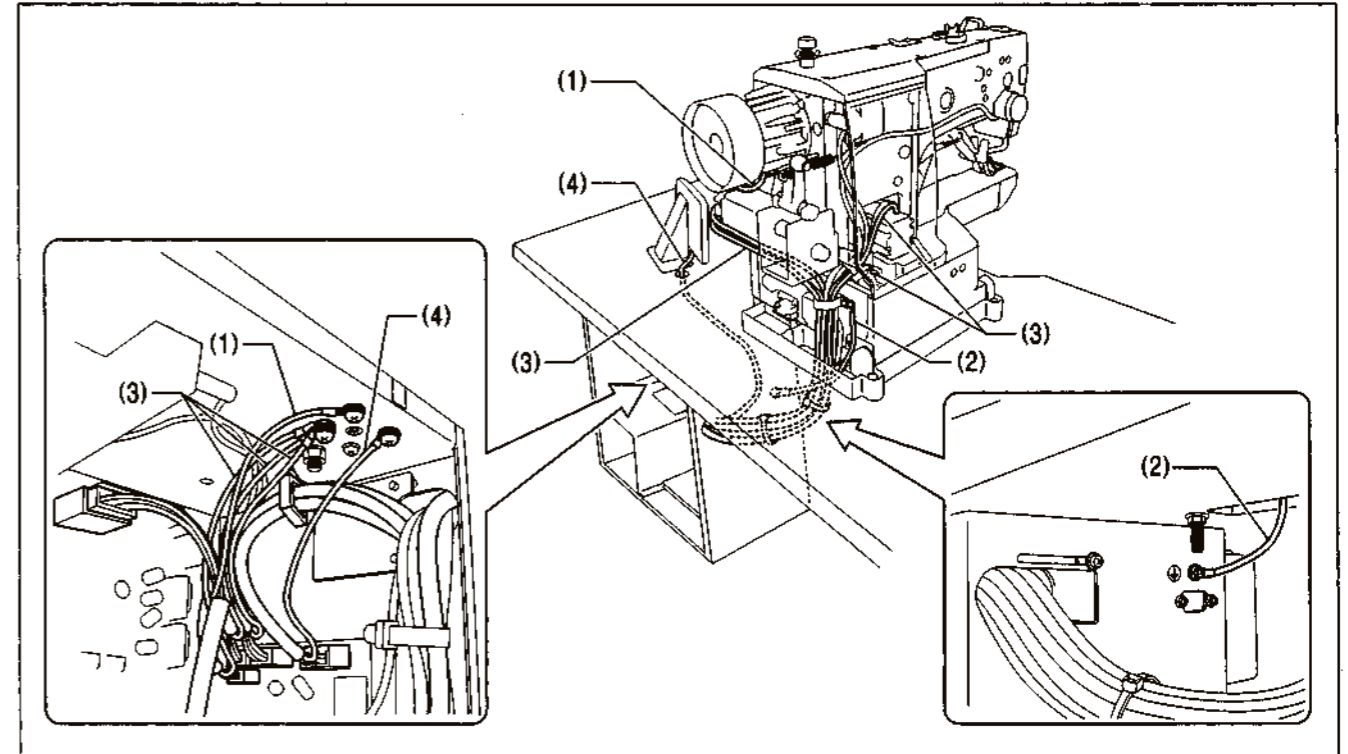

- (1) 上轴马达线束中的接地线
- (2) 来自缝纫机机头的接地线
- (3) X、Y、压脚编码器线束中的接地线 [3 根]
- (4) 操作盘线束中的接地线

· 用固定螺钉 [8 个] 拧紧控制箱的盖子。此时请确认电线等应没有被盖子夹住。

注意：为了确保安全，请可靠地进行接地。

3-12. 安装后盖

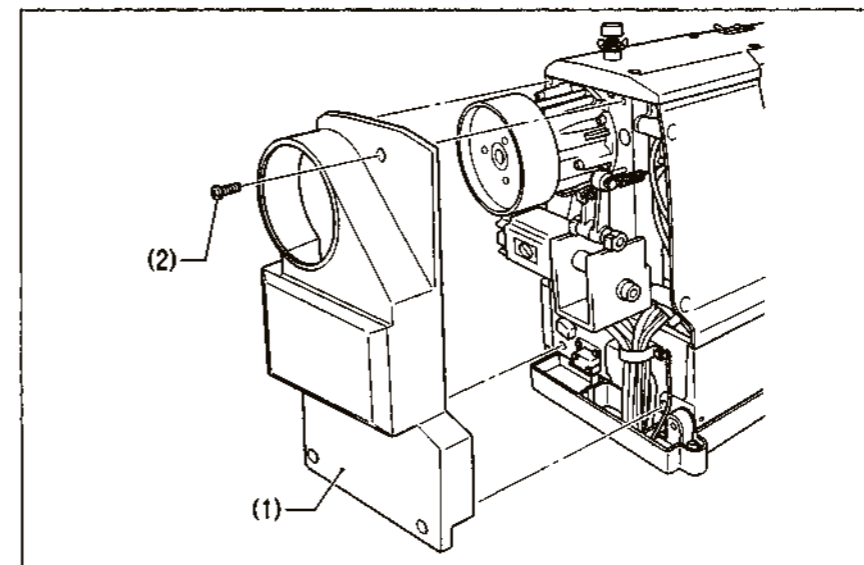



- (1) 后盖
- (2) 螺钉 [4 个]

注意：
在安装后盖 (1) 时，请注意不要夹住电线等。

3-13. 加油

注意

-  在加油未完成前，请勿插上电源。
如果误踩脚开关，缝纫机动作会导致受伤。
-  使用润滑油和黄油时，务必戴好保护眼镜和保护手套等，以防润滑油落入眼中或沾在皮肤上，这是引起发炎的原因。
另外，润滑油或黄油不能饮用，否则会引起呕吐和腹泻。
将油放在小孩拿不到的地方。

必须经常润滑缝纫机，第一次使用缝纫机或长时间未使用缝纫机时，要补充机油。
请使用指定的缝纫机润滑油（日石三菱缝纫机润滑油 10N: VG10）。

* 如果难于买到，作为推荐机油请使用（Exxon Mobil 公司的 ESSOTEX SM10: VG10）。

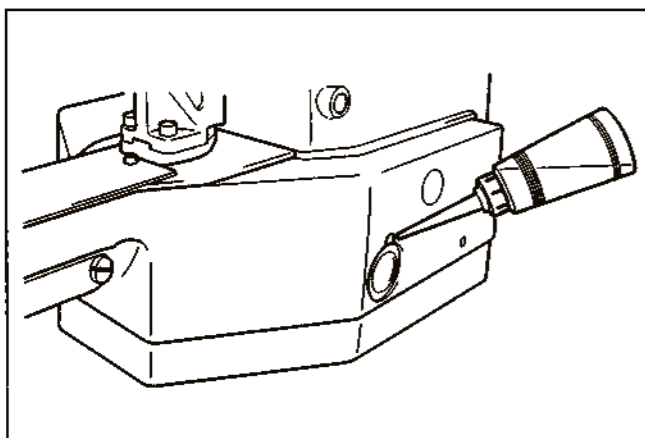

1. 给油箱注入机油。

注意:

当油面下降到油面指示窗的 1/3 左右时，请务必加注机油。如果油面下降到油面指示窗的 1/3 以下，则可能会因机器烧伤等而导致故障。

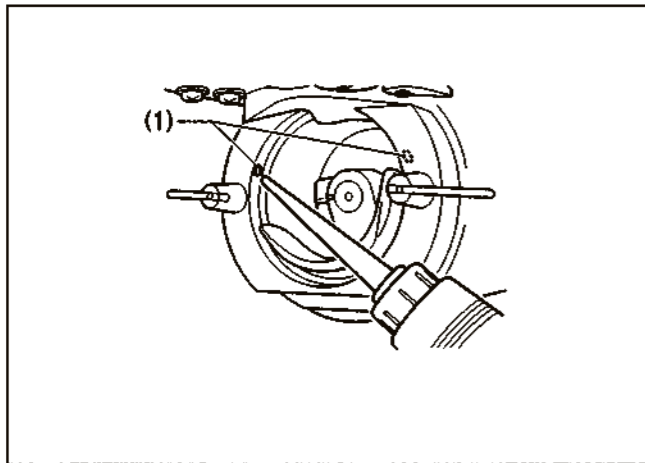

2. 给大旋梭本体组件的 2 个孔 (1) 注入机油，使毛毡上含有微量的机油。

注意:

如果大旋梭本体组件的毛毡上没有机油，则可能会引起缝纫故障。

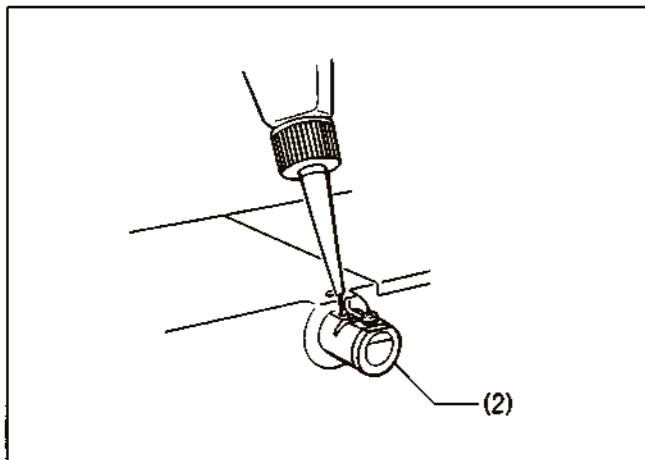

3. 如果使用冷却液箱 (2)，则请注入硅油 (100mm²/s)。

3-14. 启动

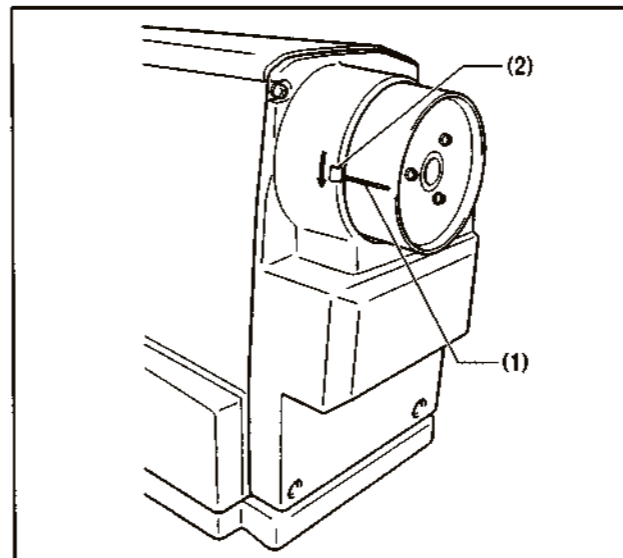

在开始原点设定前，请确认机针是否处于针上停止位置。
转动手轮，使手轮上的钢印 (1) 位于后盖上配合钢印 (2) 的范围内。

注意:

如果钢印 (1) 不在这个范围内，则在启动时就会显示错误码 [E110]。(此时，如果转动手轮将机针置于针上停止位置，则可解除错误码。)

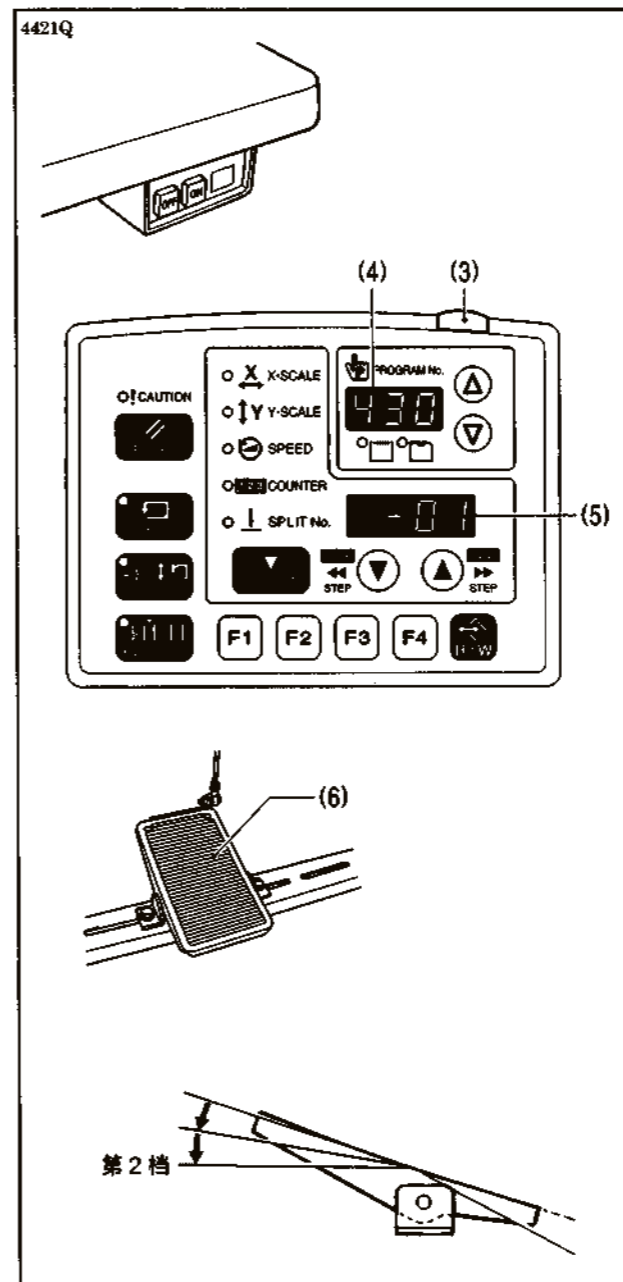

1. 打开电源。
电源指示灯 (3) 点亮，程序号 (No.) 表示 (4) 将显示机型名称，菜单表示 (5) 将显示出其规格。

规格	
普通布料	[-01]
劳动布	[-02]
女性内衣	[-07]

然后，程序号 (No.) 表示 (4) 所显示的程序号闪烁。

2. 将脚踩开关 (6) 踩到第 2 档位置。
进行原点检测，压脚/钮扣夹上升。

4. 缝纫前的准备

4-1. 机针的安装方法

注意

▲ 安装机针时，请切断电源。
当误踩下脚开关时，缝纫机会导致人员受伤。

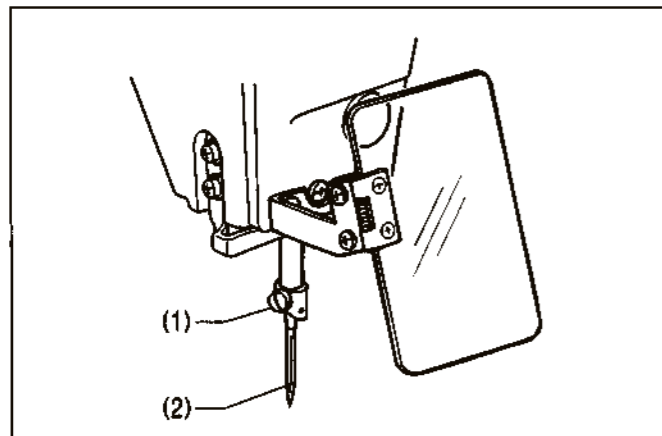

1. 松开螺钉 (1)。
2. 正面朝着机针 (2) 的长槽，笔直插到底并用力拧紧止动螺钉 (1)。

4-2. 面线的穿法

请按照下图所示正确地穿面线。

※ 如果在穿线模式下进行穿线，夹线盘 (1) 将变成打开状态，机线就更加便于穿过。(参照下一页)

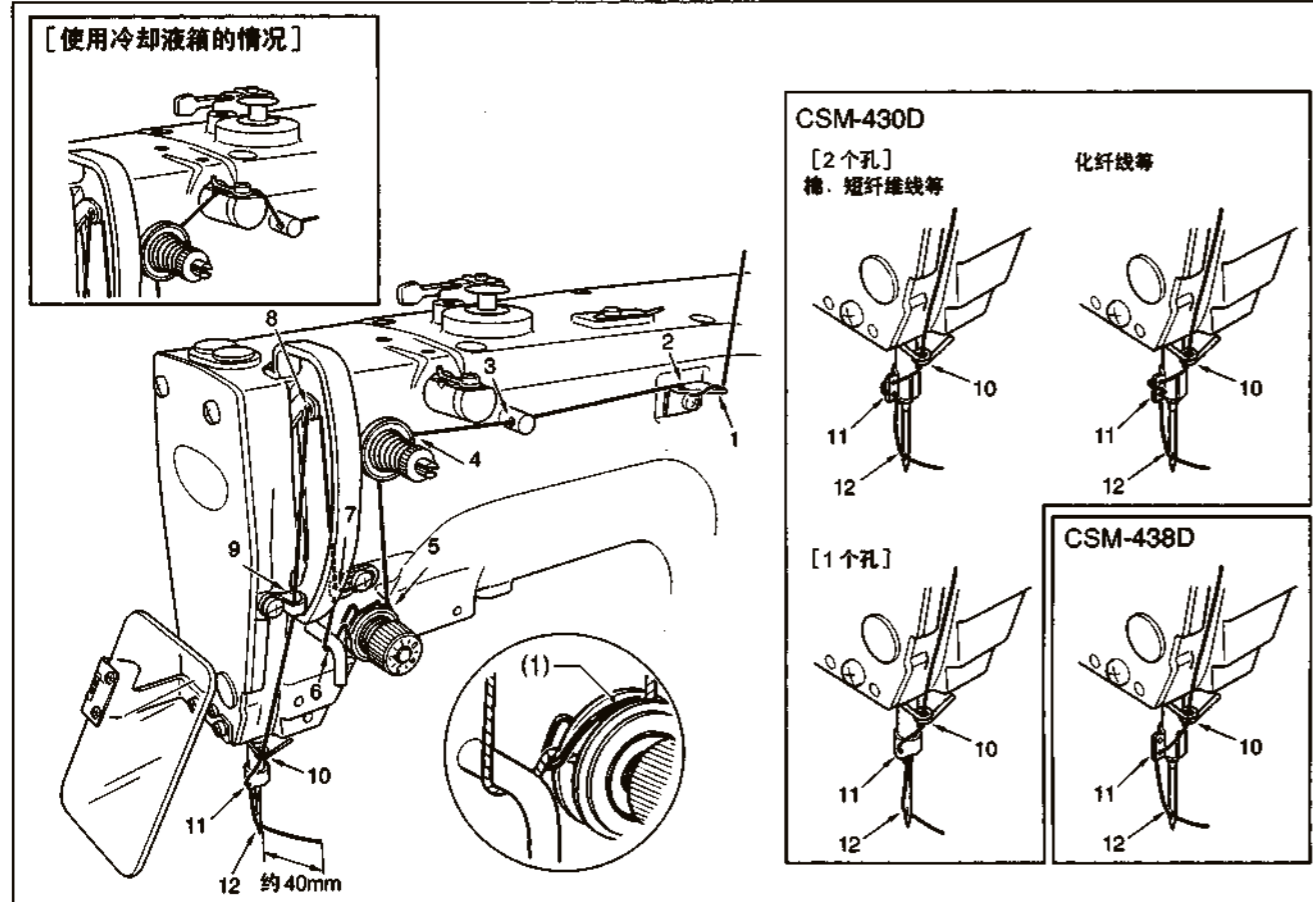

<穿线模式>

在穿线模式下，即使踩下脚踩开关，缝纫机也不会启动，所以非常安全。

1		打开电源。
2		<p>按 THREAD/CLAMP 键。</p> <ul style="list-style-type: none"> • 压脚 / 钮扣夹下降。 • 夹线盘变成打开状态。 <p>全部熄灭</p> <p>THREAD/CLAMP 灯点亮 菜单灯熄灭</p>
3	<p>进行穿线。</p> <ul style="list-style-type: none"> • 过 5 分钟后警告音鸣响，夹线盘关闭。 	
4		<p>按 THREAD/CLAMP 键。</p> <ul style="list-style-type: none"> • 压脚 / 钮扣夹返回到进入穿线模式前的状态。 <p>THREAD/CLAMP 灯熄灭</p>

4-3. 底线的绕线方法

注意

注意 在卷线过程中，不要触摸任何运动部件或将物件靠在运动部件上，因为这会导致人员受伤或缝纫机损坏。

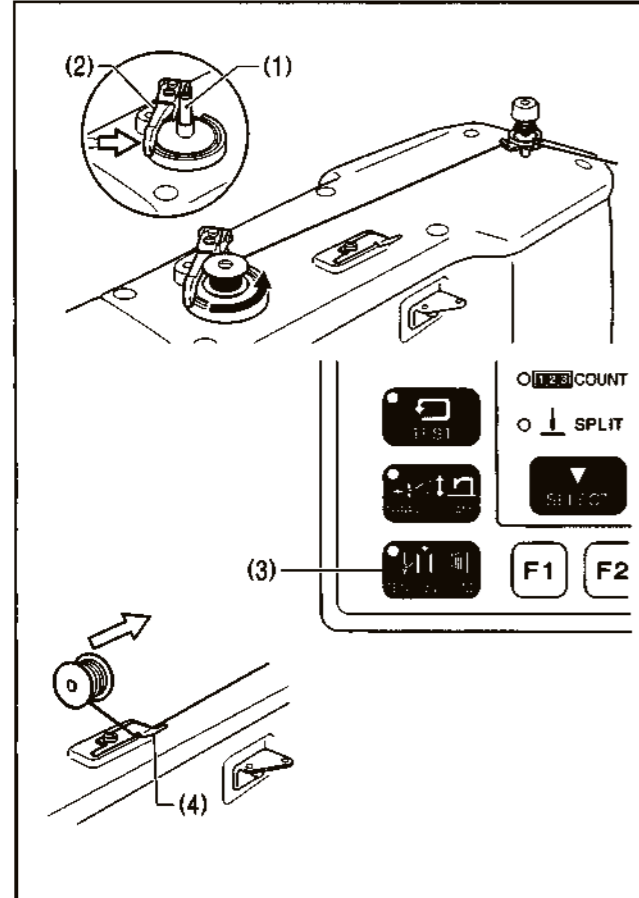

1. 将梭芯置于梭芯卷线轴(1)上。
2. 按照图示那样穿线，将线在梭芯内绕几圈，然后推梭芯压臂柄(2)。
3. 打开电源。
4. 将脚踩开关踩到第2档位置。进行原点检测。
5. 确认机针应不会碰到压脚/钮扣夹，然后一边按 TENSION/WIND 键(3)一边将脚踩开关踩到第2档位置。
6. 缝纫机开始运转后放开 TENSION/WIND 键(3)，并继续踩着脚踩开关直到绕线结束。(如果在中途放开了脚踩开关，则请再次一边按 TENSION/WIND 键(3)一边踩下脚踩开关，这样就会重新开始绕线。)
7. 当绕线量达到规定的数量(梭芯外径的80~90%)时应停止绕线，梭芯压臂柄(2)将自动返回。
8. 拆下梭芯，将线钩在切刀(4)上，朝箭头方向拉梭芯将线切断。

调节梭芯绕线量

拧松螺钉(5)，调节梭芯压杆(6)。

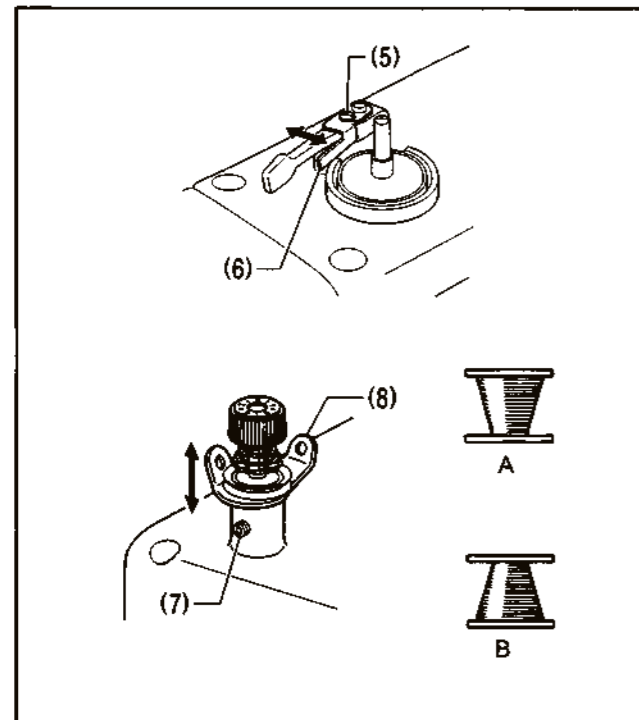
**如果梭芯上的线不均匀**

拧松止动螺钉(7)，上下移动卷线用夹线器(8)进行调节。

- ※在 A 的情况下，将卷线用夹线器(8)向下移动；
- 在 B 的情况下，将卷线用夹线器(8)向上移动。

4-4. 梭芯套的装取方法

注意

注意 在安装梭芯套时，请切断电源。
当误踩下脚开关时，缝纫机动作会导致人员受伤。

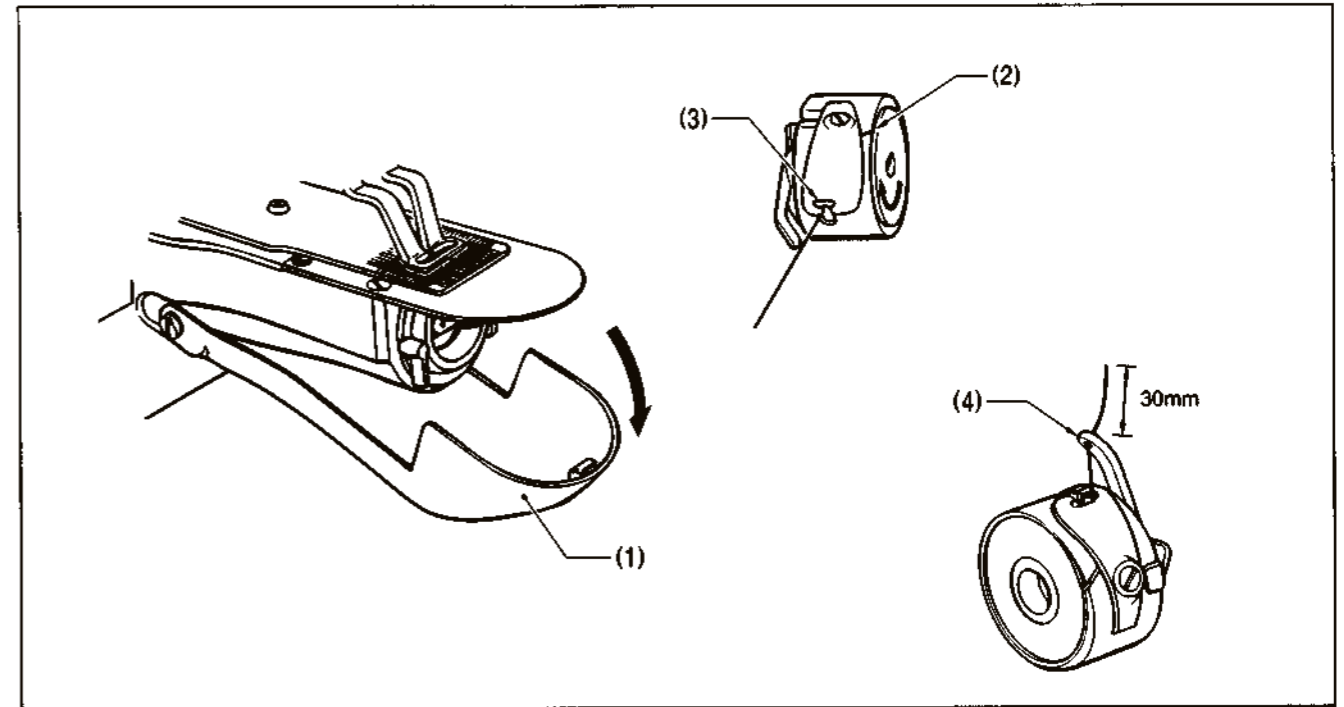

1. 向下拉大旋梭盖(1)将其打开。
2. 握住梭芯以便向右卷绕底线，将梭芯插入梭芯套。
3. 将底线穿过线槽(2)，然后从导线器(3)中拉出。
4. 当拉出底线时，检查梭芯是否按顺时针方向转动。
5. 将线穿过套柄上的线孔(4)，使线端伸出约30mm。
6. 将插销装在梭芯套上，再将梭芯套插入旋梭。

4-5. 夹线器张力

4-5-1. 底线的张力

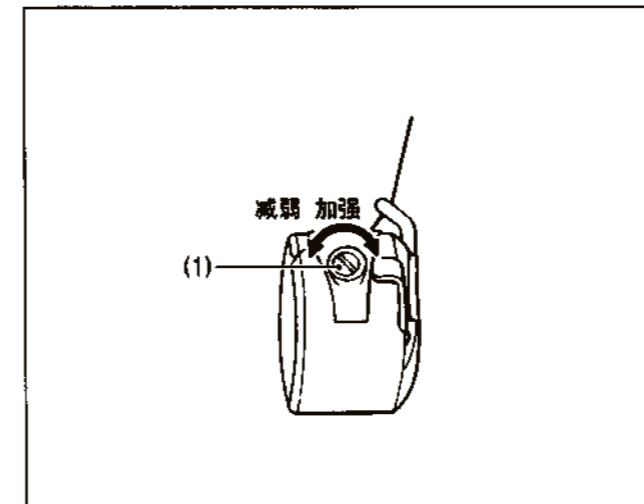

转动调节螺钉(1)来调节底线的张力，将张力调节到当用手握住线端时梭芯套靠它的自重不会滑落的程度，应尽可能减弱张力。

4-5-2. 面线的张力

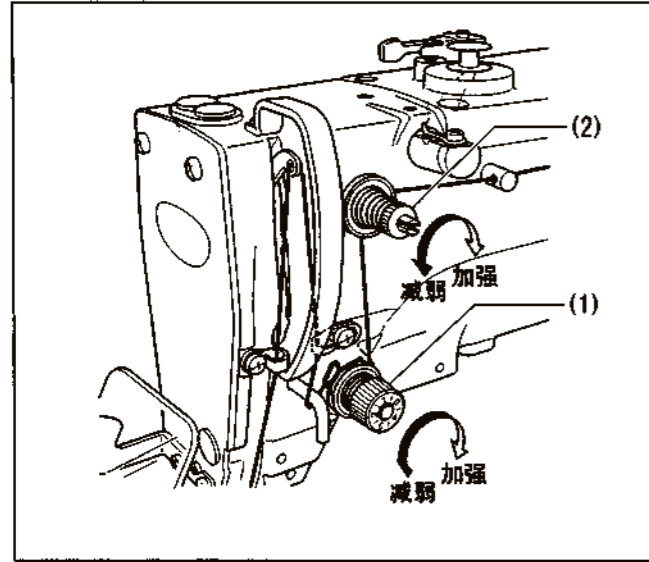

转动夹线螺母 (1)，根据缝制品进行夹线的调节 (主夹线)。

此外，还要用夹线螺母 (2) 进行调节，使面线残留量在 35~40mm 的范围内 (副夹线)。

[参考夹线]

用途	普通布料 (-01)			女性内衣 (-07)	劳动布 (-02)	
	普通布料 (-01)	女性内衣 (-07)	劳动布 (-02)			
面线	相当 50 号	相当 60 号	相当 30 号			相当 60 号
底线	相当 60 号	相当 80 号	相当 50 号			相当 60 号
面线的张力 (N)	0.8~1.2			1.6~2.0		1.0~1.8
底线的张力 (N)	0.2~0.3					0.2~0.4
预张力 (N)	0.05~0.3					0.1~0.4
针	DP×5#14	DP×5#9	DP×17NY#19			DP×17NY#12

[CSM-430D 的大致最高转速]

用途	最高缝纫速度 (rpm)	
	标准梭	双倍旋梭
粗斜纹布 8 片	3,200	2,500
粗斜纹布 12 片	2,700	
普通布料	2,700	2,500
女性内衣	2,500	

注意:

根据缝纫条件的不同，可能会发生高温断线的情况。在此情况下，请降低转速或使用冷却液箱。

4-6. 夹线装置

此装置用于缝纫开始时容易脱线、跳线等的缝纫条件。

当将存储器开关 No. 500 置于 ON 时，夹线装置将工作。(但是，有条件限制。详情请参照“6-3. 存储器开关一览表”。)

※出厂时被设置在 OFF 状态。

[使用注意事项]

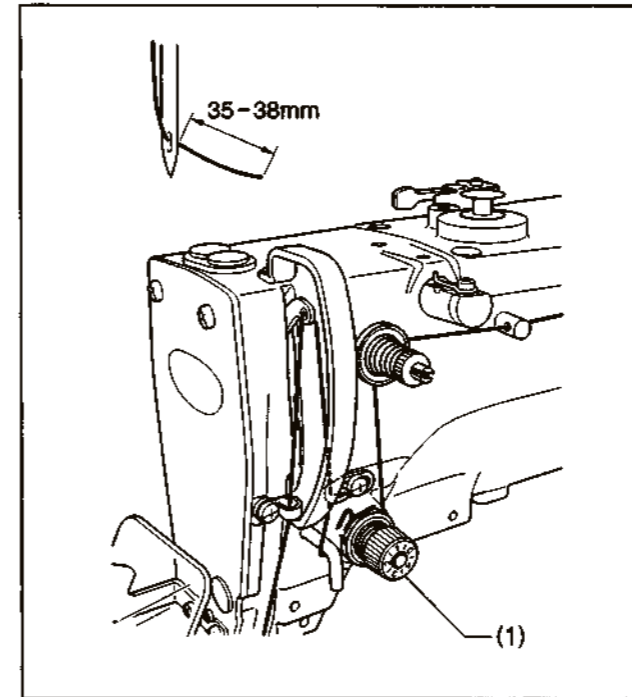

1. 当使用夹线装置时，请用夹线螺母 (1) 将面线残留量调节到 35~38mm (副夹线)。

※在更换了面线等后，也要将面线残留量控制在 40mm 以下。

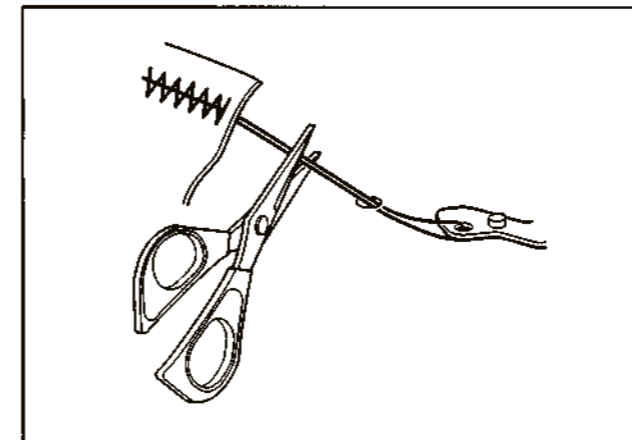

2. 当面线残留量为 40mm 以上时，或当面线张力弱而使第 1 针的面线集圈不良时，夹线装置所夹住的线端可能会被卷入线迹。

此外，如果使用 30 号以上的粗线及面线残留量过长，则可能会发生错误代码 [E691] 的情况。

在这些情况下，请用剪刀等将线剪断而不要硬将线拉断。

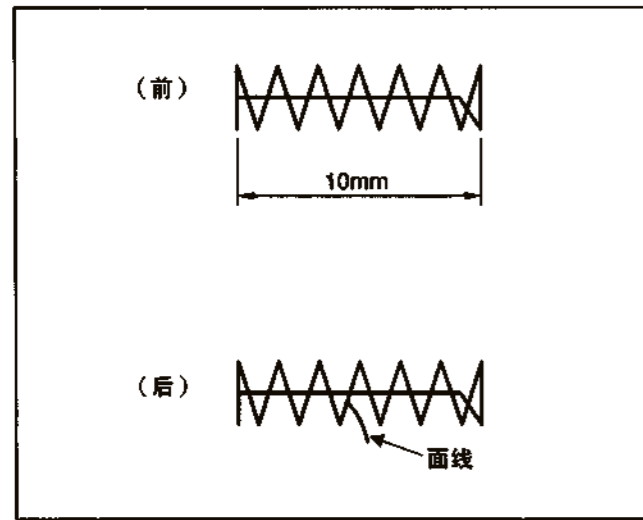

- 对于套结长度短的缝纫图案 (10mm 以下), 夹线装置所夹住的线端可能会在布料背面从线迹露出的情况。因此, 对于这样的缝纫图案, 建议将夹线装置设置在 OFF 状态。
- 当频繁发生错误代码 [E690]、[E691] 时, 请拆下针板并清除针板背面的棉屑。

- 在 CSM-430D 的情况下, 根据布料和机线的不同, 可能会发生第 2 针的底线从布料表面露出的情况。在这种情况下, 建议您使用夹线装置用的缝纫图案。关于缝纫图案的具体说明, 请参阅“2-2 预设图案表 (CSM-430D)”。

<程序号对照表>

规格	标准程序号	夹线装置用程序号
用于普通布料 (-01)	1	65
	4	66
	5	67
	8	68
	13	69
	15	70
	20	71
用于劳动布 (-02)	21	72
	2	78
	3	79
	6	80
	14	81
	16	82
	17	83
女性内衣 (-07)	18	84
	19	85
	7	73
	9	74
	22	75
	31	76
	32	77

4-7. 钮扣的插入方法

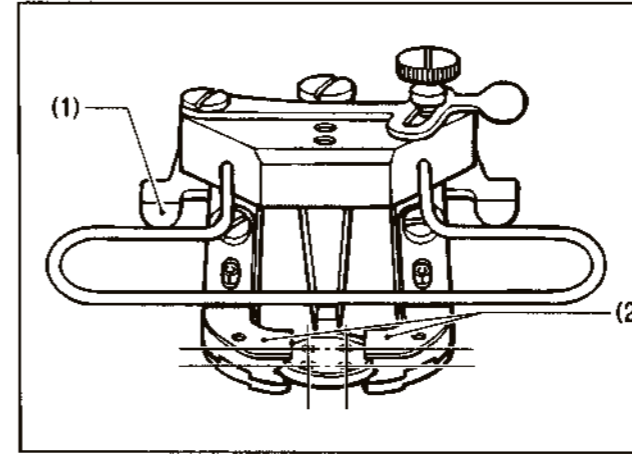

- 按下钮夹板凸轮 (1) 则钮扣夹 (2) 打开。
- 如图所示将钮扣以正确的方向插入, 放开钮夹板凸轮 (1)。

4-8. 钮扣夹的调节

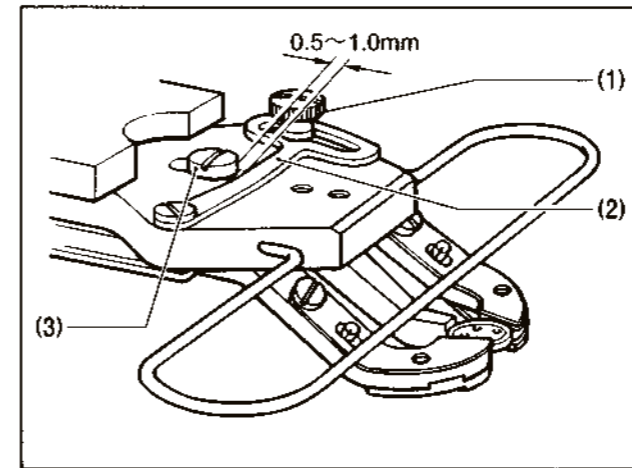

- 将钮扣插入钮扣夹, 确认钮扣是否确实被夹住。
- 在装着钮扣的状态下拧松段螺钉 (1), 移动调节板 (2), 使调节板 (2) 与固定螺钉 (3) 之间的间隙在 0.5~1.0mm 范围内, 然后拧紧段螺钉 (1)。

4-9. 钮扣上浮弹簧 (随带) 的安装方法

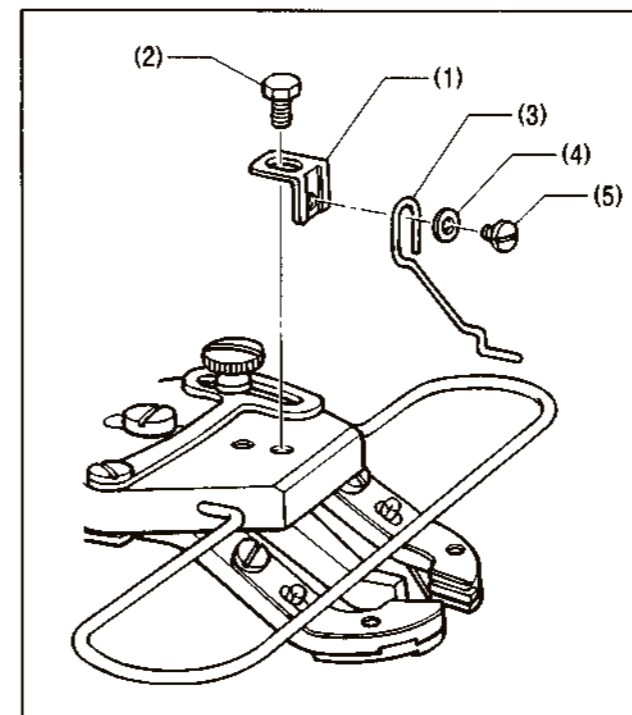

如果要将钮扣缝制得更加上浮时, 请安装此随带的钮扣上浮弹簧。

- 用螺栓 (2) 安装钮扣上浮弹簧支架 (1)。
- 用垫圈 (4) 和固定螺钉 (5) 安装钮扣上浮弹簧 (3)。

5. 操作盘的使用方法 (基本操作)

5-1. 每个操作盘部件的名称和功能

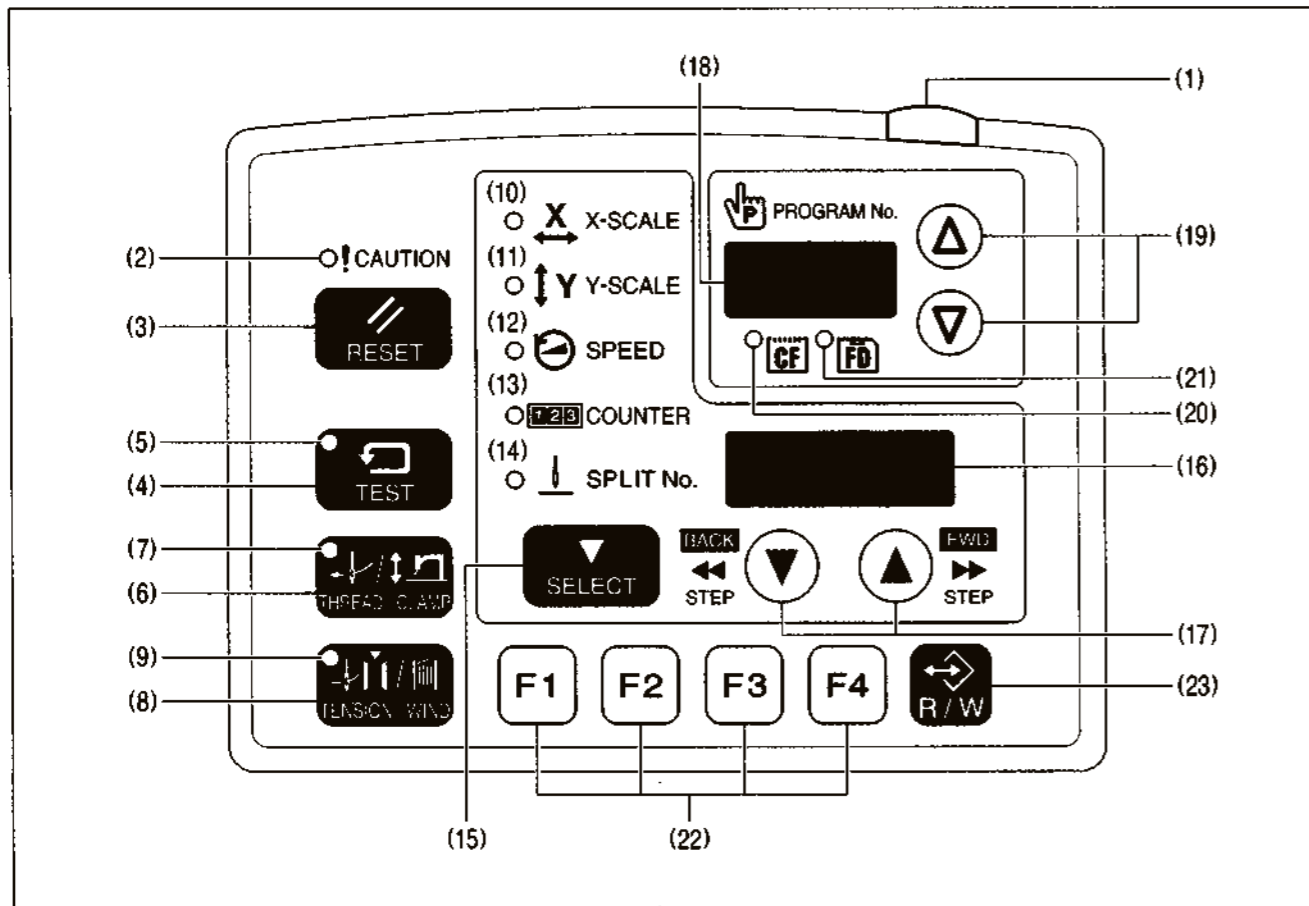

- (1) 电源指示灯
当打开电源时点亮。
- (2) CAUTION 灯
当发生错误时，此灯点亮。
- (3) RESET 键
用于解除错误。
- (4) TEST 键
要进入试验模式时，使用此键。
- (5) TEST 灯
如果按 TEST 键 (4) 则此灯点亮。
- (6) THREAD/CLAMP 键
要进入穿线模式或压脚高度设置模式时，使用此键。
- (7) THREAD/CLAMP 灯
如果按 THREAD/CLAMP 键 (6) 则此灯点亮。
- (8) TENSION/WIND 键
要卷绕底线时，使用此键。
- (9) TENSION/WIND 灯
未使用

- (10) X-SCALE 灯
当用 SELECT 键 (15) 切换到横向倍率时，此灯点亮。
- (11) Y-SCALE 灯
当用 SELECT 键 (15) 切换到纵向倍率时，此灯点亮。
- (12) SPEED 灯
当用 SELECT 键 (15) 切换到缝纫速度时，此灯点亮。
- (13) COUNTER 灯
当用 SELECT 键 (15) 切换到底线计数器/生产量计数器时，此灯点亮。
- (14) SPLIT No. 灯
当存在分割数据 (用于在程序执行中途指令暂停执行的数据) 时，如果用 SELECT 键 (15) 切换到分割状态，则此灯点亮。
- (15) SELECT 键
用于切换菜单 (横向、纵向倍率，缝纫速度，计数器)。
- (16) 菜单表示
用于显示菜单的设置值、存储器开关的内容和错误代码等。
- (17) 设置键▲▼
要变更菜单表示 (16) 所显示的数值时，使用此键。
- (18) 程序号(No.)表示
显示程序号等。
- (19) 设置键▲▽
要变更程序号(No.) 表示 (18) 所显示的数值时，使用此键。
- (20) CF 显示灯
当插入了 CF 卡 (外部媒体) 时，此灯点亮。
- (21) FD 显示灯
未使用
- (22) 功能键 [F1、F2、F3、F4]
用于用户程序的选择、循环程序的设置和选择。
- (23) R/W 键
要读写外部媒体时使用此键。

5-2. 程序号的设置方法

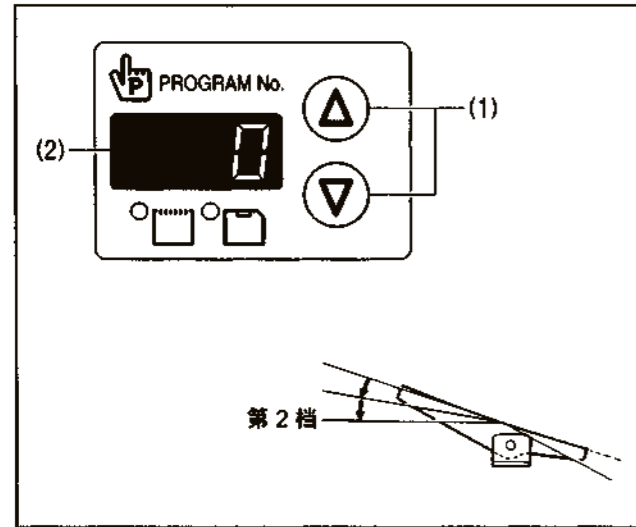

- 出厂时被设置在程序号 0 (用于确认送布原点)。
- 按▲键或▼键(1)来选择程序号。
 - 程序号(No.)表示(2)所显示的程序号将闪烁。
 - 将脚踏开关踩到第 2 档位置。
 - 进行原点检测, 确定程序号。
 - 程序号从闪烁变成点亮。

注意:
设置结束后, 请务必进行“5-5./5-6. 缝纫图案的确认”, 并确认落针位置是否正确。

5-3. 横向倍率/纵向倍率的设置方法

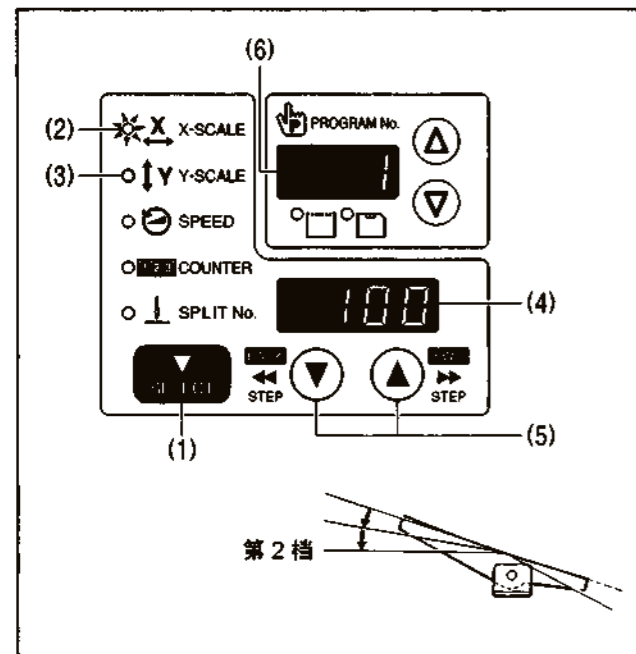

- 出厂时倍率被设置在 100%。
- 按 SELECT 键(1), 使横向倍率的 X-SCALE 指示灯(2)、纵向倍率的 Y-SCALE 指示灯(3)点亮。
 - 菜单表示(4)将显示设置值(%)。
 - ※ 当存储器开关 No. 402 位于 ON 时, 数值以 mm 表示。
 - 按▲键或▼键(5)来设置倍率(20~200)。
 - 程序号(No.)表示(6)所显示的程序号将闪烁。
 - 将脚踏开关踩到第 2 档位置。
 - 进行原点检测, 确定倍率。
 - 程序号从闪烁变成点亮。

注意:
设置结束后, 请务必进行“5-5./5-6. 缝纫图案的确认”, 并确认落针位置是否正确。



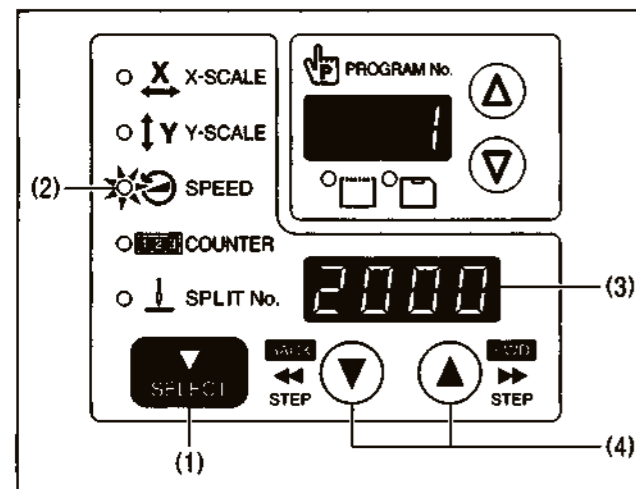

5-4. 缝纫速度的设置方法



- 出厂时缝纫速度被设置在 2000 (rpm)。
- 按 SELECT 键(1), 使 SPEED 指示灯(2)点亮。
 - 菜单表示(3)将显示设置值(rpm)。
 - 按▲键或▼键(4)来设置缝纫速度。
(缝纫速度设置值 CSM-430D : 400 ~ 3200 , CSM-438D : 400~2700)

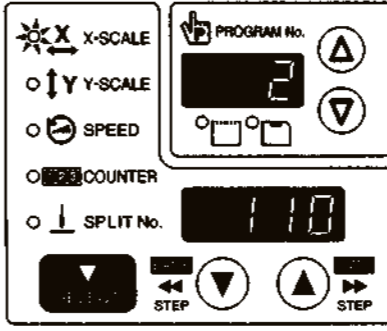
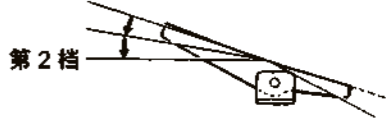
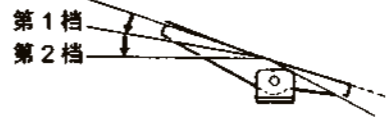





5-5. 缝纫图案的确认

利用试送布模式, 仅使布料移动来确认运针情况。
请确认针孔应不超出压脚的范围。

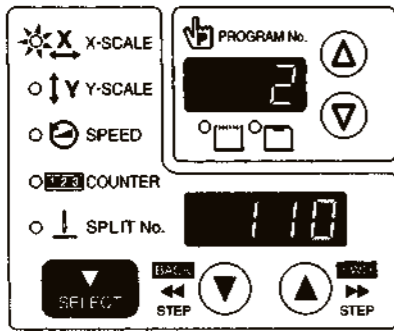
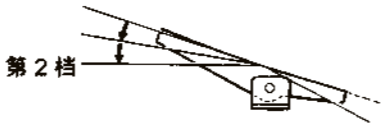
1	 <p>TEST 灯点亮</p>	<p>按 TEST 键。</p>
2	 <p>程序号闪烁→点亮。</p>	<p>选择想确认的程序号, 设置横向倍率、纵向倍率。</p> <ul style="list-style-type: none"> · 程序号闪烁。 <p>将脚踏开关踩到第 2 档位置。</p> <ul style="list-style-type: none"> · 进行原点检测, 程序号从闪烁变成点亮。 
3	<p>连续试送布模式开始</p>  <div data-bbox="1753 1046 2887 1574" style="border: 1px solid black; padding: 5px;"> <p>[中途缝纫等待模式] 4441Q</p>  <p>TEST 灯点亮</p> <p>TEST 灯熄灭</p>  <p>· 如果在这个模式下按▲键, 送布应前进 1 针; 如果按▼键, 送布就后退 1 针。(如果连续按着不放, 就快速送布。)</p> <p>· 要再开始试送布时, 请按 TEST 键。</p> </div>	<p>将脚踏开关踩到第 2 档位置后放开。</p> <ul style="list-style-type: none"> · 送布 1 针接 1 针开始连续移动。 <p>[快送布试验模式]</p> <p>如果在布料移动时将脚踏开关踩到第 1 档位置, 则在踩着期间可以加快送布速度。</p> <p>要从试送布中途开始缝纫时, 请按 TEST 键使 TEST 灯熄灭。如果将脚踏开关踩到第 2 档位置, 就开始缝纫。</p>
4	 <p>TEST 灯点亮</p>	<p>试送布进行到最后一针时就停止送布。</p> <p>按 TEST 键。</p>
5		<p>TEST 灯熄灭</p> <p>将脚踏开关踩到第 1 档位置。 压脚上升后, 缝纫准备完毕。</p>

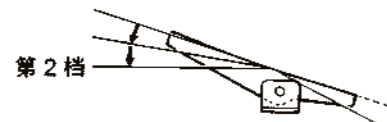

5-6. 缝纫图案的确认

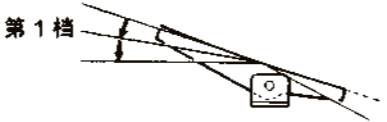
利用试送布模式, 仅使布料移动来确认运针情况。

1	 <p>按 TEST 键。</p> <p>TEST 灯点亮</p>
2	 <p>选择想确认的程序号, 设置横向倍率, 纵向倍率。</p> <ul style="list-style-type: none"> 程序号闪烁。 <p>将脚踏开关踩到第 2 档位置。</p> <ul style="list-style-type: none"> 进行原点检测, 程序号从闪烁变成点亮。  <p>第 2 档</p> <p>程序号闪烁→点亮。</p>
3	<p>装上钮扣 (参照“4-7. 钮扣的插入方法”)</p>
4	<p>开始进行 1 针试送布模式</p> <p>将脚踏开关踩到第 2 档位置后放开。</p> <ul style="list-style-type: none"> 送布只移动 1 针。  <p>第 1 档 第 2 档</p> <p>然后每次将脚踏开关踩到第 1 档位置, 送布就逐针移动。当每移动 1 针时用手转动手轮, 确认机针应在不接触钮扣的情况下进入钮扣孔中。(此时, 如果朝缝纫机旋转方向转动手轮 1 转, 则在起针位置附近送布就移动 1 针。)</p> <p>此外, 如果再次将脚踏开关踩到第 2 档位置, 送布就 1 针接 1 针开始连续移动。</p> <div data-bbox="196 1160 1315 1688" style="border: 1px solid black; padding: 5px;"> <p>[中途缝纫等待模式]</p> <p>要从试送布中途开始缝纫时, 请按 TEST 键使 TEST 灯熄灭。如果将脚踏开关踩到第 2 档位置, 就开始缝纫。</p>  <p>TEST 灯熄灭</p>  <p>第 2 档</p>  <p>BACK STEP FWD STEP</p> <ul style="list-style-type: none"> 如果在这个模式下按▲键, 送布应前进 1 针; 如果按▼键, 送布就后退 1 针。(如果连续按着不放, 就快速送布。) 要再开始 1 针试送布时, 请按 TEST 键。  <p>TEST 灯点亮</p> </div>
5	<p>试送布结束。</p> <p>按 TEST 键。</p>  <p>TEST 灯熄灭</p>
6	<p>将脚踏开关踩到第 1 档位置。</p> <p>压脚上升后, 缝纫准备完毕。</p>  <p>第 1 档</p>

5-7. 压脚/钮扣夹上升量的设置

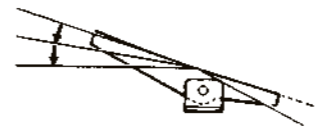
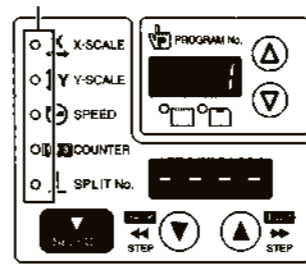
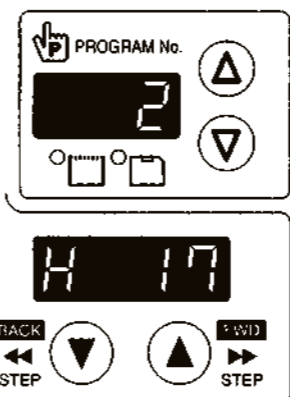
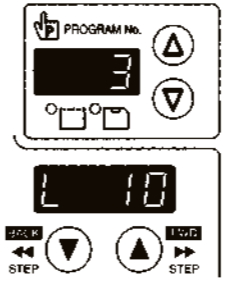
可以在操作盘变更压脚/钮扣夹上升量的设置值。



1	 <p>进行原点检测。</p>
2	<p>全部熄灭</p>  <p>按 THREAD/CLAMP 键。</p> <p>进入穿线模式。</p> <ul style="list-style-type: none"> 程序号 (No.) 表示将显示 [1], 压脚/钮扣夹下降。 <p>THREAD/CLAMP 灯点亮 菜单灯熄灭</p>
3	<p>按▲键。</p> <p>进入压脚高度设置模式。</p> <ul style="list-style-type: none"> 程序号 (No.) 表示将显示 [2], 压脚/钮扣夹一直上升到菜单表示所显示的设置值。 (压脚高度设置值 CSM-430D: 10~17, CSM-438D: 6~13) <p>注意:</p> <p>在 原点检测前的状态下, 即使按▲键也不会进入压脚高度设置模式。(蜂鸣器鸣响。) 按 THREAD/CLAMP 键结束设置模式, 请重新从项目 1, 开始进行。</p> <p>按▲键或▼键来设置压脚的高度。</p> <ul style="list-style-type: none"> 压脚/钮扣夹将根据设置的高度上升、下降。 
	<p>存储器开关 No.003 在 ON 位置时</p>  <p>按▲键。</p> <p>进入中间压脚高度设置模式。</p> <ul style="list-style-type: none"> 程序号 (No.) 表示将显示 [3], 压脚/钮扣夹一直移动到菜单表示所显示的设置值。 (中间压脚高度设置值 CSM-430D: 1~17, CSM-438D: 1~13) <p>按▲键或▼键来设置中间压脚高度。</p> <ul style="list-style-type: none"> 压脚/钮扣夹将根据设置的高度上升、下降。
	<p><模式的变换></p> <p>[2] 压脚高度设置模式</p> <p>↓ ↑</p> <p>([3] 中间压脚高度设置模式)</p> <p>↓ ↑</p> <p>[1] 穿线模式</p>
4	<p>设置模式结束</p>  <p>按 THREAD/CLAMP 键。</p> <ul style="list-style-type: none"> 记忆设置值。 压脚/钮扣夹回复到进入设置模式前的状态。 <p>THREAD/CLAMP 灯熄灭</p>

6. 操作盘的使用方法 (上级操作)

6-1. 实用功能一览

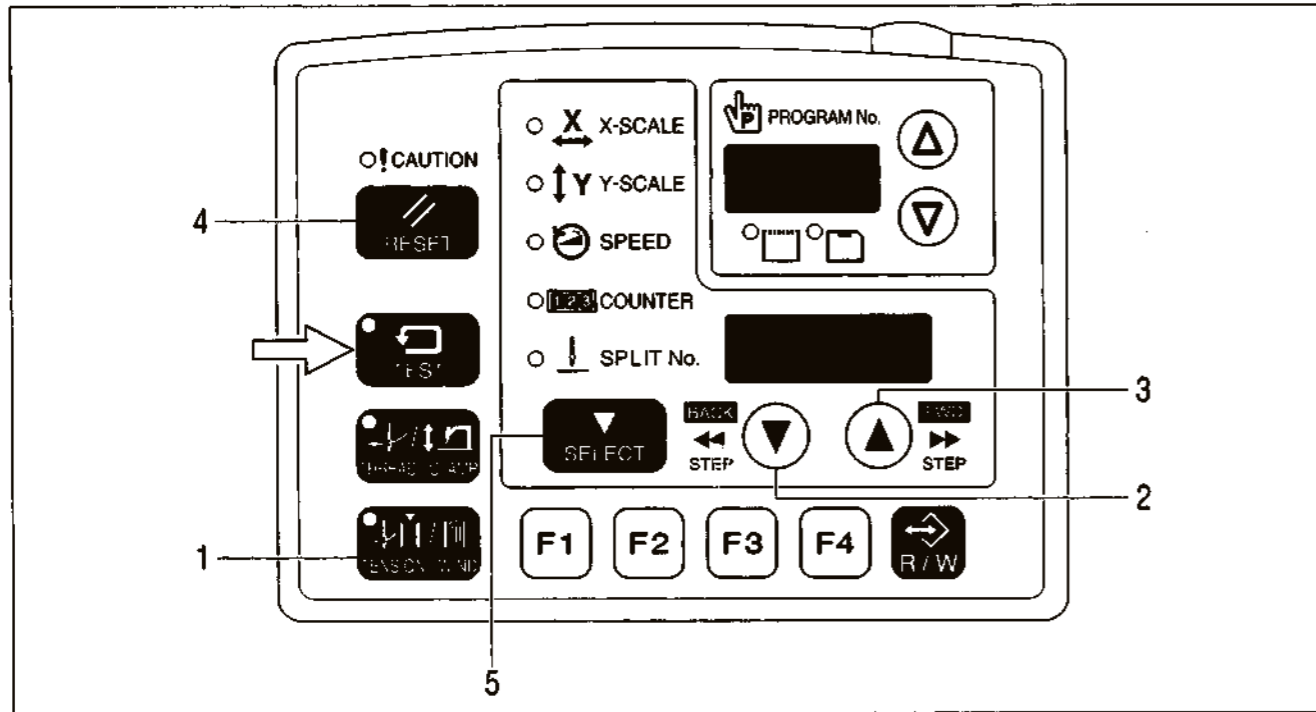
在按 TEST 键的同时, 按各相互组合的键。



1	 + 	存储器开关设置模式 (参照“6-2. 存储器开关的设置方法”)
2	 + 	底线计数器设置模式 (参照“6-4. 底线计数器的使用方法”)
3	 + 	生产量计数器设置模式 (参照“6-5. 生产量计数器的使用方法”)
4	SPEED 灯点亮时  + 	生产量计数器一时显示功能 (参照“6-5. 生产量计数器的使用方法”)
5	 + 	用户程序设置模式 (参照“6-6. 用户程序的使用方法”)

6-2. 存储器开关的设置方法

1

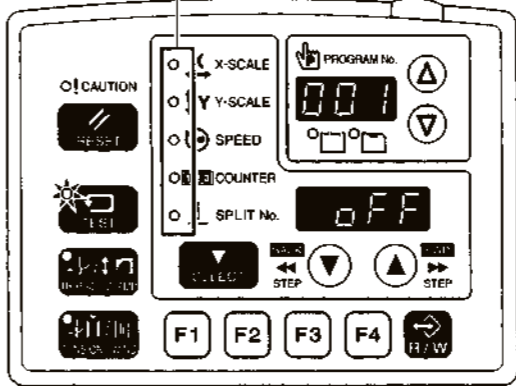

全部熄灭

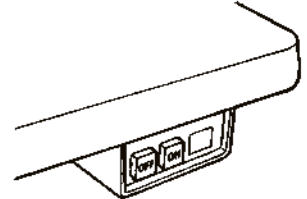

当按下 SELECT 键时, 打开电源开关。
※ 在显示机型名称后, 请按下 SELECT 键直至蜂鸣器发出“啵”的响声。

或者
在电源接通的状态下, 同时按 TEST 键和 TENSION/WIND 键。

· 程序号 (No.) 表示将显示存储器开关号码, 菜单表示将显示该号码的设置值。

菜单灯熄灭、TEST 灯点亮

2

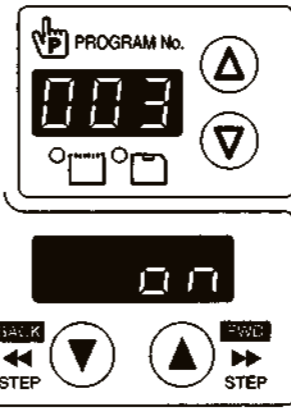

按▲键或▼键来选择存储器开关号码。

按▲键或▼键来变更设置值。

要想只显示从初始值起所变更的存储器开关号码时

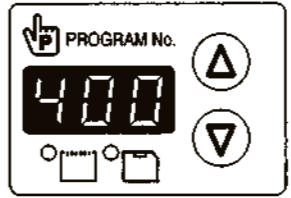
在按 SELECT 键的同时按▲键或▼键。

- 依次显示从初始值起所变更的存储器开关号码。
- 如果没有从初始值起所变更的存储器开关号码, 显示就不变化并且蜂鸣器发出“啵—啵—”的鸣响声。

3 设置模式结束



按 TEST 键。

- 变更内容被存储, 成为等待原点检测的状态。

TEST 灯熄灭



- 想要将一个存储器开关的设置值作为初始值时, 请在显示该存储器开关号码的状态下按 RESET 键。
- 想要将所有存储器开关的设置值作为初始值时, 请按下 RESET 键保持 2 秒钟以上直到蜂鸣器发出“啵—”的鸣响声。

6-3. 存储器开关一览表

号码	设置范围	设置项	初始值
001	缝纫结束后的压脚/钮扣夹上升时间		OFF
	OFF	在最后一针的位置上升	
	ON	在移动到缝纫开始后上升	
003	2 档压脚		OFF
	OFF	无效	
	ON	在踏板第 1 档的中间停止, 踩到第 2 档时下降后起动的。	
100	起始速度		※1
	OFF	缝纫开始时 1~5 针的速度将根据存储器开关 No. 151~155 的设置状况而定。 (关于存储器开关 No. 151~155, 请参照调整说明书。)	
	ON	CSM-430D: 第 1 针为 400rpm, 第 2 针为 800rpm。 CSM-438D: 第 1 针和第 2 针以为 400rpm。	
200	1 针试送布		※1
	OFF	试送布随着踩下脚踩开关而开始, 并自动前进到最后一针。	
	ON	试送布随着踩下脚踩开关而逐针前进。 而且, 当试验灯点亮时, 通过用手转动缝纫机手轮则试送布将逐针前进。	
300	生产量计数器显示		OFF
	OFF	底线计数器显示	
	ON	生产量计数器显示	
400	用户程序		OFF
	OFF	无效	
	ON	用户程序模式变为有效	
401	循环程序		OFF
	OFF	无效	
	ON	在以用户程序缝纫时, 将按照已设置的程序依次进行缝纫。	
402	放大缩小率的 mm 表示 (※2)		OFF
	OFF	以 % 表示	
	ON	以 mm 表示	
500	夹线装置		OFF
	OFF	无效	
	ON	使夹线装置工作 (※3)	

※1 CSM-430D 为 OFF, CSM-438D 为 ON。





※2 显示尺寸 (mm) 可能与实际的缝纫尺寸有所差异。

※3 当更改了存储器开关 No. 151 和 152 的设定时, 或者因缝纫速度而可能发生不工作的情况。(关于存储器开关 No. 151 和 152, 请参照调整说明书。)

6-4. 底线计数器的使用方法

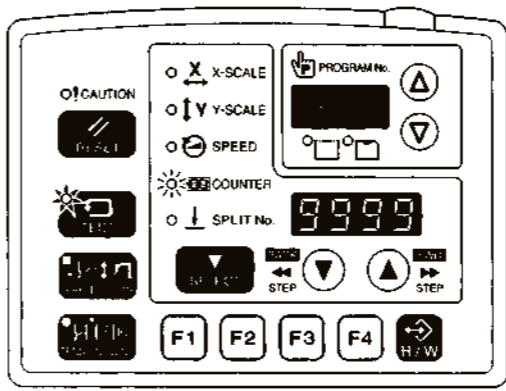
如果根据梭芯内的缝线量预先将能够缝制的片数设置于底线计数器, 这样就能防止在缝制中途底线用完的情况。

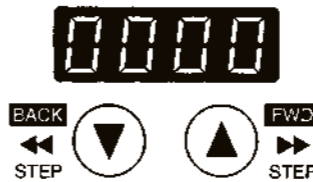
<初始值的设定>

1	 <p>在按 TEST 键的同时按▼键。</p> <p>TEST 灯点亮、COUNTER 灯闪烁</p>	 <p>菜单表示将显示以前所设置的初始值。</p>
2	 <p>按▲键或▼键来设置初始值。</p> <p>TEST 灯熄灭</p>	<p>按▲键或▼键来设置初始值。</p> <ul style="list-style-type: none"> 初始值可设置在 1 片 [0001] ~ 9999 片 [9999] 的范围内。 如果将数值设为“0000”, 底线计数器将不能工作。 如果在设置模式中按 RESET 键, 数值就变成 [0000]。
3	 <p>设置模式结束</p>	<p>按 TEST 键。</p> <ul style="list-style-type: none"> 初始值被存储。

<底线计数器操作>

当存储器开关 No. 300 在 OFF 时, 如果按 SELECT 键 (1) 以选择计数器显示菜单, COUNTER 灯就点亮, 菜单表示 (2) 将显示底线计数器。

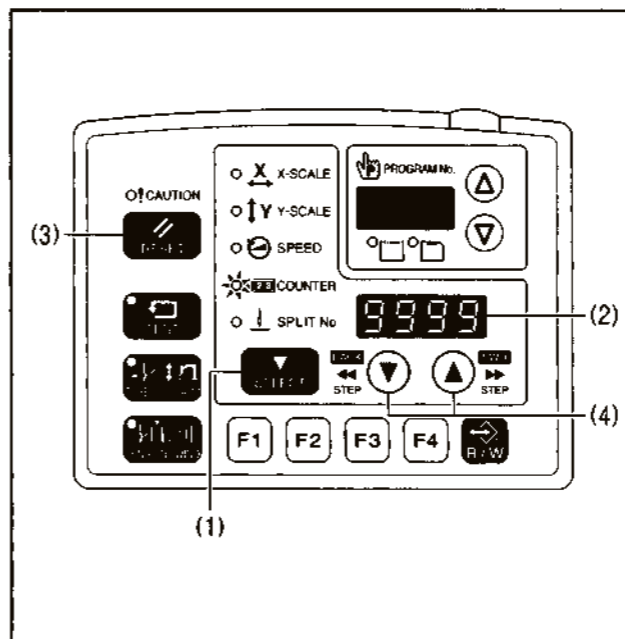





- 每结束一次缝纫, 菜单表示 (2) 所显示的数值就减小 1。
- 当底线计数器变成 [0000] 时, 电子蜂鸣器就连续鸣响。这时, 即使踩下脚踩开关缝纫机也不工作。
- 如果按 RESET 键 (3), 电子蜂鸣器就停止鸣响, 菜单表示 (2) 将显示底线计数器的初始值, 变成可缝纫的状态。
 - 当没有设置初始值时, 则显示 [0000]。

※ 按▲键或▼键 (4), 可任意设置底线计数器值。但是, 这个数值不能作为初始值被存储。

※ 如果设置了底线计数器, 即使不在底线计数器显示状态, 计数器也照常进行计数动作。

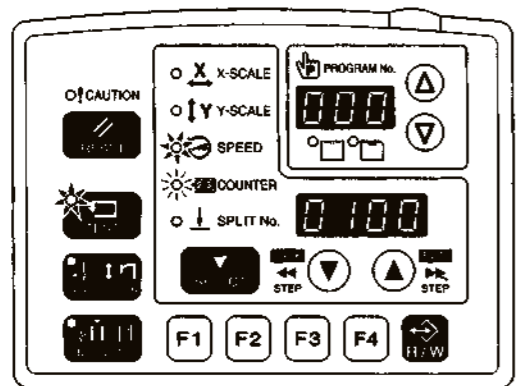
6-5. 生产量计数器的使用方法

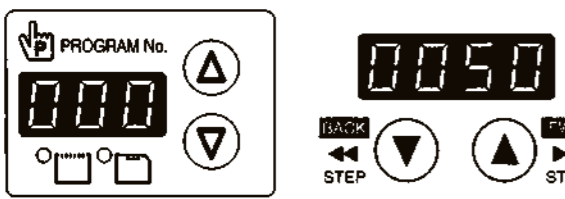
<计数值的设置>

<p>1</p>  <p>TEST 和 SPEED 灯点亮 COUNTER 灯闪烁</p>	<p>在按 TEST 键的同时按▲键。</p>  <ul style="list-style-type: none"> • 程序号 (No.) 表示和菜单表示以 7 位数显示以前设置的计数值。
<p>2</p> 	<p>按▲键或▼键来设置计数值。</p> <ul style="list-style-type: none"> • 计数值可设置在 [000] [0000] ~ [999] [9999] 的范围内。 • 如果在设置模式中按 RESET 键, 数值就变成成为 [000] [0000]。
<p>3 设置模式结束</p>  <p>TEST 灯熄灭</p>	<p>按 TEST 键。</p> <ul style="list-style-type: none"> • 计数值被存储。

<生产量计数器操作>

存储器开关 No. 300 为 ON 时, 如果按 SELECT 键 (1) 以选择计数器显示菜单, 则 SPEED 和 COUNTER 灯点亮, 菜单表示 (2) 将显示生产量计数器。

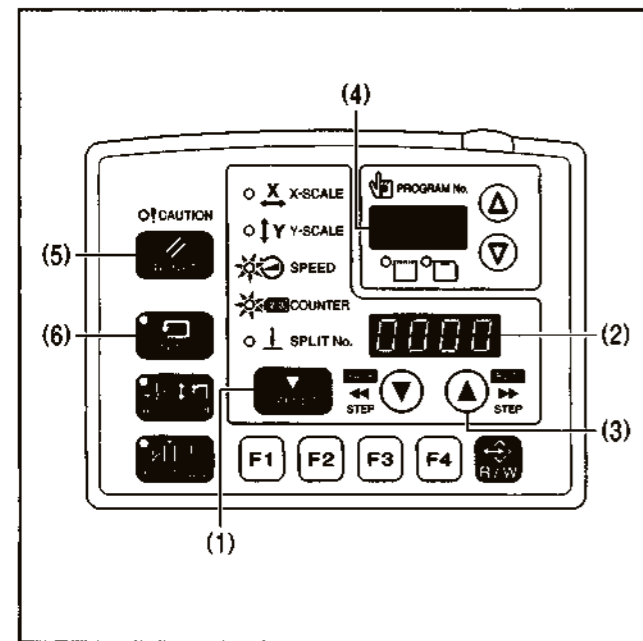

1. 每结束一次缝纫, 菜单表示 (2) 所显示的数值就增大 1。
2. 在按着▲键 (3) 期间, 程序号 (No.) 表示 (4) 将显示 3 位的数值, 显示位合计为 7 位数。
3. 如果按着 RESET 键 (5) 保持 2 秒钟以上, 计数器的值就复位到 [0000]。









一时显示功能

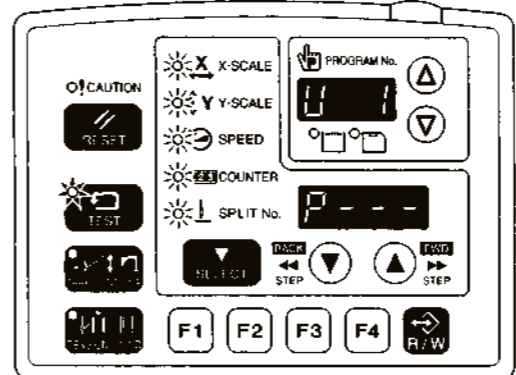

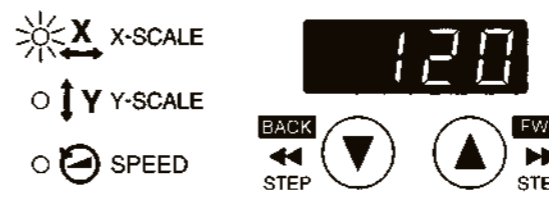
在底线计数器显示中, 可以一时显示生产量计数器。当 SPEED 指示灯点亮时, 如果在按 TEST 键 (6) 的同时按 RESET 键 (5), 则菜单表示 (2) 将显示生产量计数器。通过按 TEST 键 (6) 或用 SELECT 键 (1) 切换菜单, 可以恢复原来的菜单表示。
※ 在一时显示的状态下, 也可以进入缝纫操作。

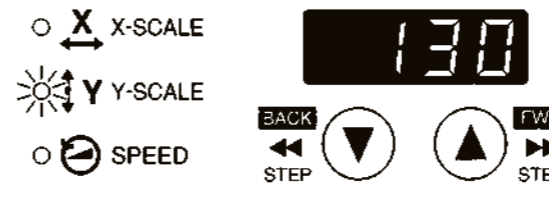
6-6. 用户程序的使用方法

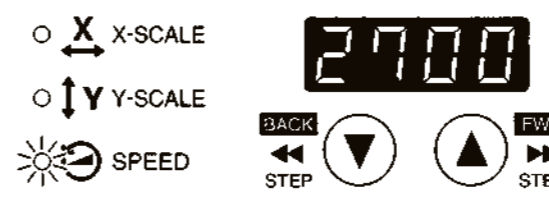
可以登录程序号、横向倍率、纵向倍率、缝纫速度、压脚高度等最多 50 种 (U1~U50) 参数。要切换所决定的缝纫图案加以使用时, 如果预先登录到用户程序则更为方便。用户程序在存储器开关 No.400 为 ON 时有效。

<登录方法>

<p>1 选择用户程序号</p>  <p>TEST 灯点亮, 菜单灯闪烁</p>	<p>在按 TEST 键的同时按 SELECT 键。</p>  <ul style="list-style-type: none"> • 进入用户程序登录模式。请确认菜单灯应闪烁。 • 程序号 (No.) 表示将显示用户程序号, 菜单表示将显示 [P---]。 <p>按▲键或▼键来选择用户程序号。</p>
<p>2 首先设置程序号</p> 	<p>按▲键或▼键, 设置要登录的程序号。</p>
<p>3 接着设置横向倍率</p>  <p>X-SCALE 灯闪烁</p>	<p>按 SELECT 键。</p>  <p>按▲键或▼键, 设置要登录的横向倍率。</p>
<p>4 然后设置纵向倍率</p>  <p>Y-SCALE 灯闪烁</p>	<p>按 SELECT 键。</p>  <p>按▲键或▼键, 设置要登录的纵向倍率。</p>
<p>5 然后设置缝纫速度</p>  <p>SPEED 灯闪烁</p>	<p>按 SELECT 键。</p>  <p>按▲键或▼键, 设置要登录的缝纫速度。</p>

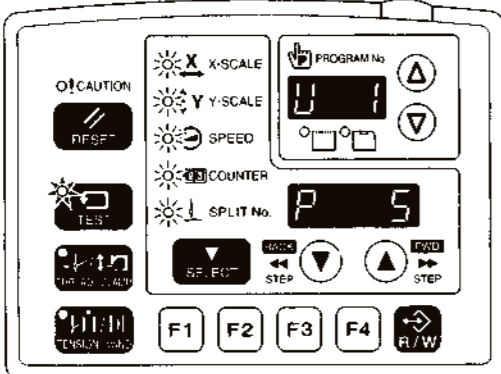
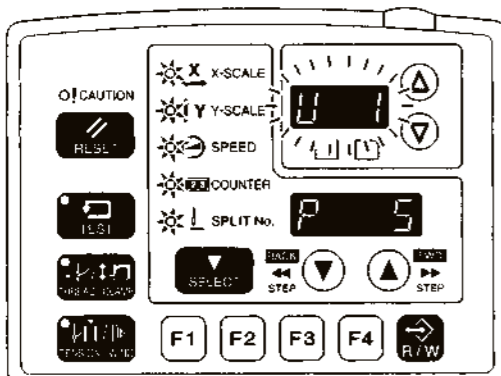
6	<p>然后设置压脚高度</p>  <p>按 SELECT 键。</p> <p>按▲键或▼键，设置要登录的压脚高度。</p> <p>THREAD/CLAMP 灯闪烁</p>	
7	<p>最后设置中间压脚高度 (仅当菜单开关 No.003 为 ON 时)</p>  <p>按 SELECT 键。</p> <p>按▲键或▼键，设置要登录的中间压脚高度。</p> <p>THREAD/CLAMP 灯闪烁</p>	
8	 <p>按 SELECT 键。</p> <ul style="list-style-type: none"> 要继续设置其他的用户程序时，请选择用户程序号并重复进行操作步骤 2-8。 <p>TEST 灯点亮，菜单灯闪烁</p>	
9	 <p>按 SELECT 键。</p> <p>到此，用户程序已被登录。</p> <ul style="list-style-type: none"> 程序号 (No.) 表示所显示的用户程序号闪烁，成为等待原点检测状态。 <p>TEST 灯熄灭，菜单灯点亮</p>	

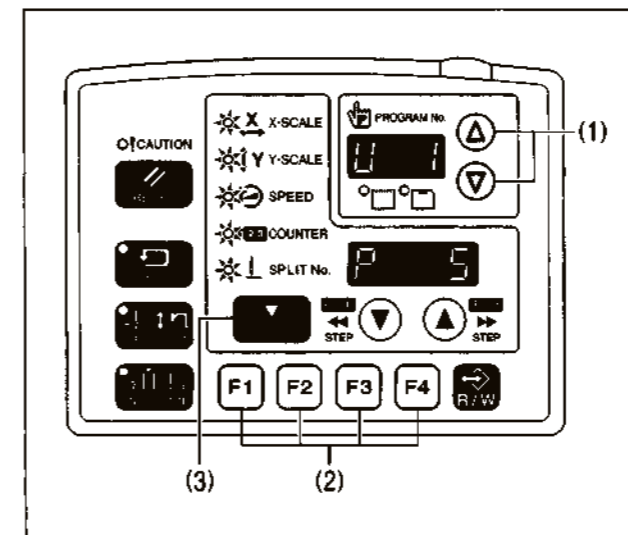

<使用方法>



- 按▲键或▼键 (1)，选择要缝制的用户程序号。
 - 当用户程序号闪烁时，如果踩下脚踏开关就进行原点检测。此后，即使改变用户程序号，只要不关闭电源开关就不必再进行原点检测。
 - 可以用功能键 F1~F4 (2) 直接选择用户程序 U1~U10。(参照“6-8. 直接选择的方法”)
- 确认落针位置是否正确，然后进行缝纫。(参照“5-5./5-6. 缝纫图案的确认”)

· 如果按 SELECT 键 (3)，就可以确认所显示的用户程序内容 (X 标尺、Y 标尺、缝纫速度等)。

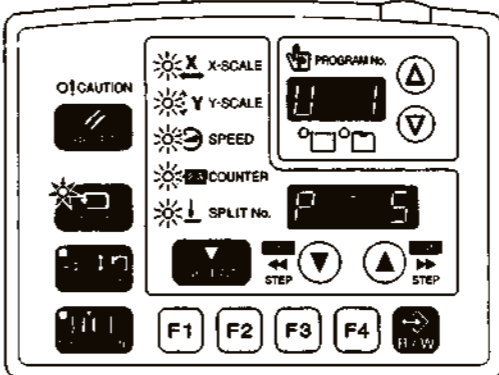
<删除方法>

1	 <p>在按 TEST 键的同时按 SELECT 键。</p>  <ul style="list-style-type: none"> 进入用户程序登录模式。请确认菜单灯应闪烁。 程序号 (No.) 表示将显示用户程序号，菜单表示将显示程序号。 <p>按▲键或▼键，选择要删除的用户程序号。</p> <p>TEST 灯点亮，菜单灯闪烁</p>	
2	 <p>按 RESET 键。</p> <ul style="list-style-type: none"> 蜂鸣器鸣响，所选择的用户程序被删除。 <p>注意： 被删除的用户程序如果已登录在循环程序中，则该用户程序所登录的程序步将成为空置状态。所以，不能删除循环程序。</p> <p>按住 RESET 键 2 秒钟或更长的时间。</p> <ul style="list-style-type: none"> 蜂鸣器鸣响，所有的用户程序都被删除。 <p>注意： 如果已登录了循环程序，则循环程序也被全部删除。</p> <p>用户程序全部删除</p>	

6-7. 循环程序的使用方法





可以将已登录在用户程序中的缝纫图案登录在最多为9种 (C-1~C-9) 的循环程序中。

1个循环程序最多可以设置15个程序步。

要依次缝纫已决定的缝纫图案时, 如果预先登录在循环程序中则更为方便。

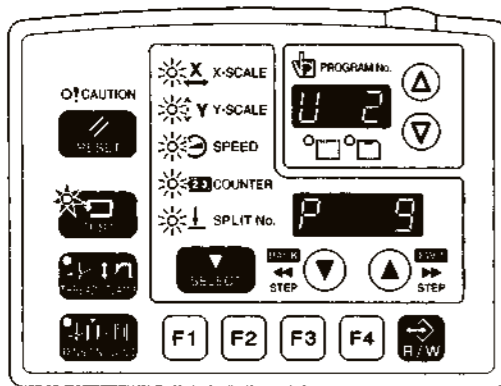
循环程序在存储器开关 No.400 和 No.401 为 ON 时有效。

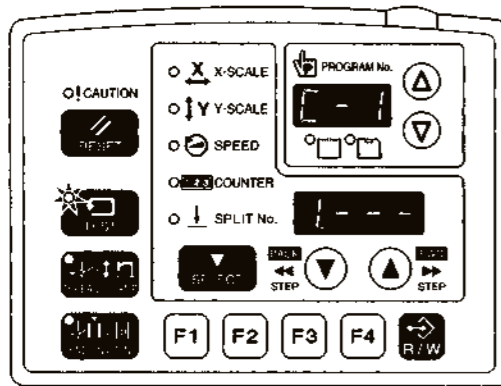
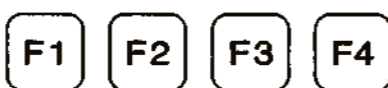
<登录方法>

<p>1 进入用户程序登录模式</p>  <p>TEST 灯点亮, 菜单灯闪烁</p>	<p>在按 TEST 键的同时按 SELECT 键。</p>  <ul style="list-style-type: none"> · 请确认菜单灯应闪烁。 · 程序号 (No.) 表示将显示用户程序号, 菜单表示将显示程序号。 <p>把要登录在循环程序中的缝纫图案登录在用户程序中。</p>
<p>2 进入循环程序登录模式, 选择循环程序号</p>  <p>菜单灯熄灭</p>	<p>按功能键 F1~F4 中的某一个键。</p>  <ul style="list-style-type: none"> · 程序号 (No.) 表示将显示循环程序号 C-1~C-4, 菜单表示将显示 [1. ---]。 <p>按功能键 F1~F4 或按△▽键来选择循环程序号。</p>
<p>3 设置程序步 1</p> 	<p>按▲键或▼键, 设置要登录的用户程序号。 按 SELECT 键。</p> 
<p>4 程序步 2 以后也同样进行设置。 程序步 9 以后将以 [A. ---] [b. ---] [c. ---] [d. ---] [E. ---] [F. ---] 的顺序显示。</p> <p>要在设置中返回到前一程序步时 <循环程序 C-1~C-4 的情况></p> <ol style="list-style-type: none"> 1. 如果分别按功能键 F1~F4, 就返回到程序步 1 的显示。 2. 按 SELECT 键直至达到所需的程序步。 <p><循环程序 C-5~C-9 的情况></p> <ol style="list-style-type: none"> 1. 按▲键或▼键来切换循环程序号。 2. 再次选择所需的循环程序号, 按 SELECT 键直至达到所需的程序步。 	

5 要继续登录其他的循环程序时, 请重复进行操作步骤 2~4。

6 结束循环程序登录模式

按 TEST 键。

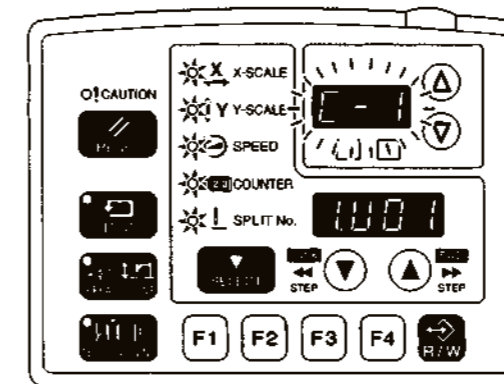

TEST 灯熄灭, 菜单灯点亮

到此, 循环程序已被登录。

- 程序号 (No.) 表示所显示的循环程序号闪烁, 成为等待原点检测状态。

<使用方法>

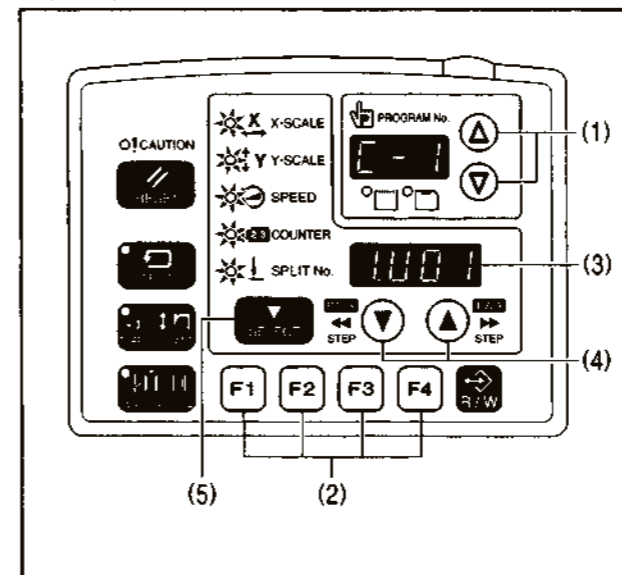

1. 按▲键或▼键 (1), 选择要使用的循环程序号。

- 当循环程序号闪烁时, 如果踩下脚踏开关就进行原点检测。此后, 即使改变循环程序号, 只要不关闭电源开关就不必再进行原点检测。
- 可以用功能键 F1~F4 (2) 直接选择循环程序号。(参照“6-8. 直接选择的方法”)

2. 确认落针位置是否正确, 然后进行缝纫。(参照“5-5./5-6. 缝纫图案的确认”)

3. 所登录的用户程序将按照程序步依次执行, 当最后的程序步结束时, 菜单表示 (3) 就返回到程序步 1 的显示。

- 如果按▲键或▼键 (4), 就可以返回到前一个程序步或跳到下一个程序步。(不必重新进行原点检测。)
- 如果按 SELECT 键 (5), 就可以确认所显示程序步的用户程序内容 (X 标尺、Y 标尺、缝纫速度等)。但是, 不能进行更改。

注意:

在循环程序缝纫模式 (存储器开关 No. 401 为 ON) 时, 如果没有被登录的循环程序, 就以用户程序的号码依次进行缝纫。

<删除方法>

1 在按 TEST 键的同时按 SELECT 键。

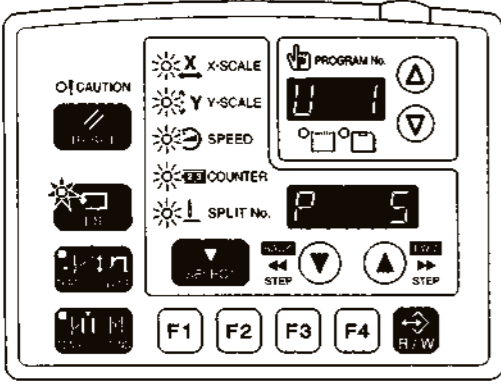

TEST SELECT

- 进入用户程序登录模式。请确认菜单灯应闪烁。

TEST 灯点亮，菜单灯闪烁

2 按功能键 F1~F4 中的某一个键。

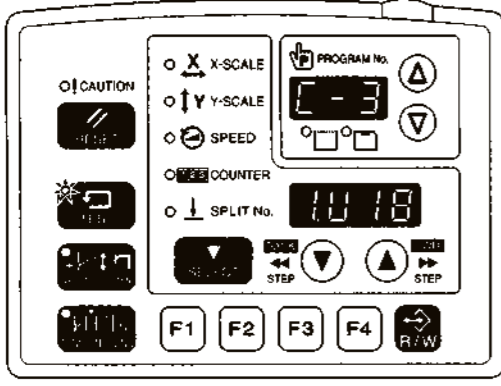

F1 F2 F3 F4

- 进入循环程序登录模式。

按功能键 F1~F4 或 Δ/∇ 键，选择要删除的循环程序号。

菜单灯熄灭

3 按 RESET 键。



- 蜂鸣器鸣响，所选择的循环程序被删除。

循环程序全部删除

按住 RESET 键 2 秒钟或更长的时间。

- 蜂鸣器鸣响，所有的循环程序都被删除。

注意：
如果在循环程序登录后执行用户程序的全部删除，则所登录的循环程序也被全部删除。

6-8. 直接选择的方法

使用功能键可以直接选择用户程序号或循环程序号。

使用功能键 F1~F4 可以选择 U1~U4、C-1~C-4。

同时按几个组合的功能键 F1~F4 (加法组合) 可以选择 U5~U10、C-5~C-9。

<组合表>

U5 / C-5	U6 / C-6	U7 / C-7
F1 + F4	F2 + F4	F3 + F4
或者	或者	或者
F2 + F3	F1 + F2 + F3	F1 + F2 + F4
U8 / C-8	U9 / C-9	U10
F1 + F3 + F4	F2 + F3 + F4	F1 + F2 + F3 + F4

6-9. 追加缝纫数据的读取方法

1 在电源开关关闭的状态下，将 CF 卡插入 CF 插入口。

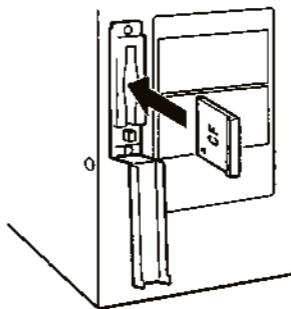

注意：
· 请注意 CF 卡的插入方向。
· 除了在插入或拔出 CF 卡以外，请一定将盖子盖上。因灰尘等的进入是造成故障的原因。

2 打开电源。
按 Δ 键或 ∇ 键来选择程序号 (200~999)。

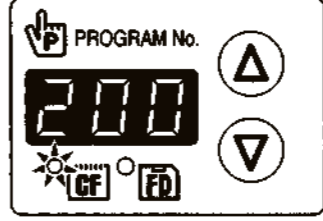

CF 显示灯点亮

- 不显示 CF 卡上不存在的缝纫数据的程序号。

3 按 R/W 键。



- 蜂鸣器鸣响，从 CF 卡向内部存储器读取并复制所选择的缝纫数据。

在读取中

4 读取结束

- 程序号 (No.) 表示将从 [P] 变为所选择的程序号。

7. 缝纫

⚠ 注意

- 发生下列情况时, 请切断电源。
当误踩脚开关时, 缝纫机动作会导致受伤。
- 机针穿线时
 - 更换机针或梭芯时
 - 缝纫机不使用, 或人离开缝纫机时。

缝纫过程中不要触摸任何活动部件或将物件靠在运动部件上, 因为这会导致受伤或缝纫机损坏。

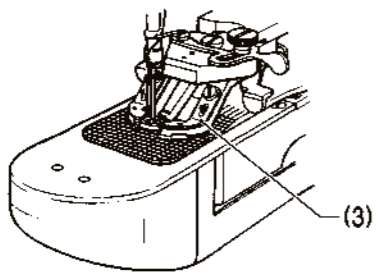
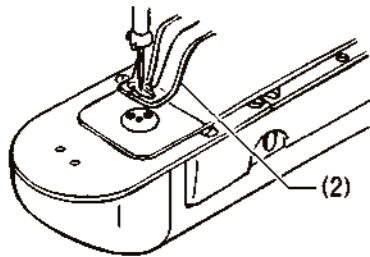
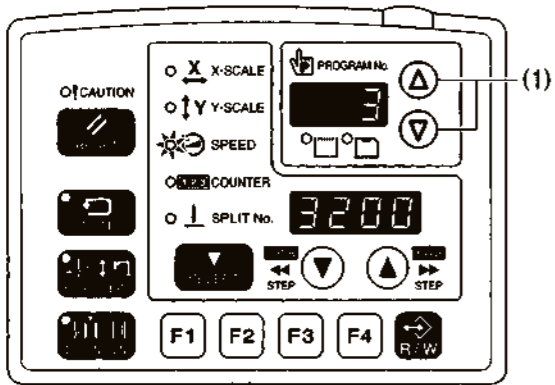

1. 打开电源。
2. 按△键或▽键 (1), 选择要缝纫的程序号。

3. 将脚踩开关踩到第2档位置。
进行原点检测。

4. 将布料放在压脚 (2) 下面
(如果是 CSM-438D, 则应插入钮扣, 将布料放在钮扣夹 (3) 的下面。请参照“4-7. 钮扣的插入方法”)
5. 将脚踩开关踩到第1档。
压脚 (2) / 钮扣夹 (3) 下降。
6. 将脚踩开关踩到第2档位置。缝纫机起动。

※ 如果存储器开关 No.003 为 ON, 则当踩到第1档时, 压脚 (2) / 钮扣夹 (3) 将下降到中间停止位置; 而踩到第2档时就压住布料, 与此同时缝纫机起动。

7. 缝纫一结束就剪线, 然后压脚 (2) / 钮扣夹 (3) 上升。

8. 保养

⚠ 注意

- 在开始清洁作业前, 请切断电源。
如果误踩了脚开关, 缝纫机动作会导致人员受伤。
- 使用润滑油和黄油时, 务必戴好保护眼镜和保护手套等, 以防润滑油落入眼中或沾在皮肤上, 这是引起发炎的原因。
另外, 润滑油或黄油不能饮用, 否则会引起呕吐和腹泻。
将油放在小孩拿不到的地方。

8-1. 旋梭的清洁

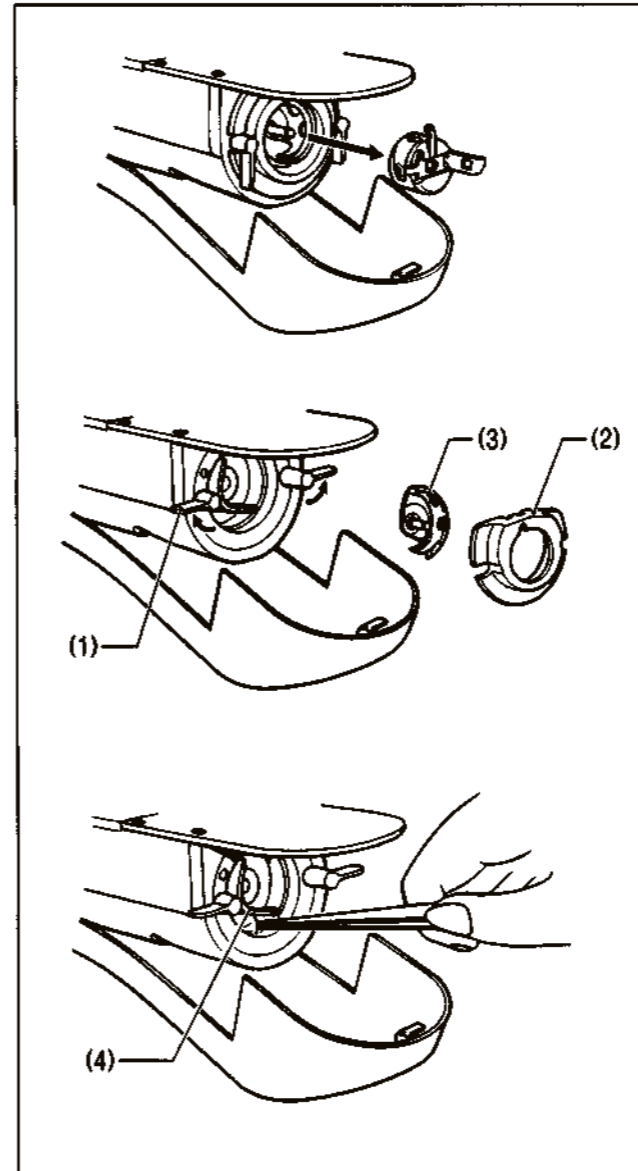

1. 将大旋梭盖向下拉开, 取出梭芯盒。

2. 将大旋梭固定柄 (1) 朝箭头方向打开, 取出大旋梭 (2) 和中旋梭 (3)。

3. 将梭托 (4) 四周、旋梭线导向上部及旋梭边缘的棉尘和线屑等擦干净。

8-2. 控制箱进气口的清洁

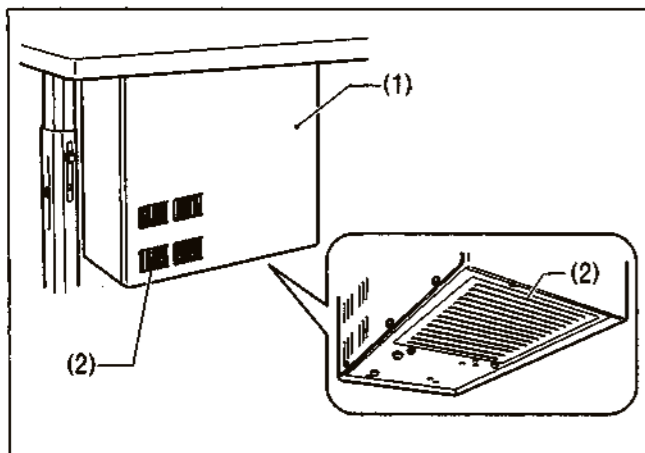

请每月一次左右用吸尘器清洁控制箱 (1) 进气口 (2) 处的滤网。

8-3. 更换润滑油

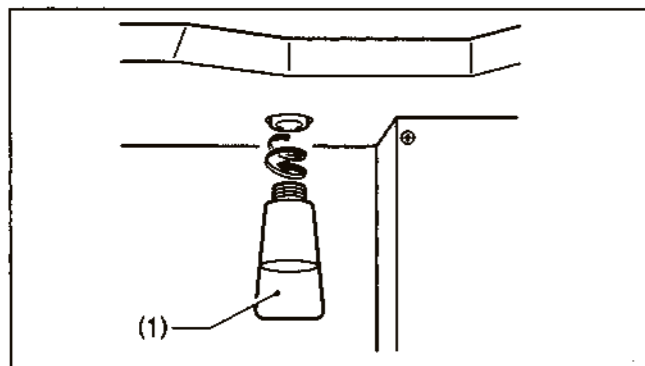

1. 如果注油器瓶 (1) 内积满了油, 则请拆下瓶将油倒掉。
2. 油倒掉后, 再将注油器瓶 (1) 拧入到原来位置。

8-4. 护眼板的清洁

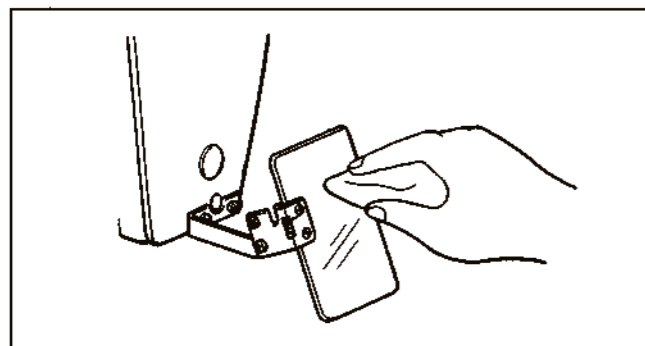

护眼器污秽时, 请用软布将其擦拭干净。

注意:

请勿使用有机溶液如汽油或稀释剂清洁护眼器。

8-5. 机针的检查

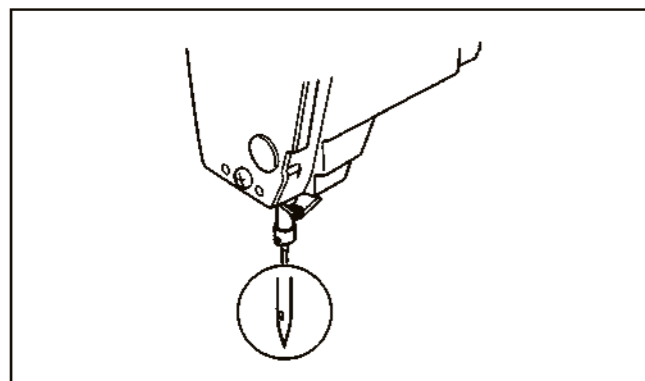

缝纫开始前先确认针头有否断裂, 机针有否弯曲。

8-6. 加油

参照“3-13. 加油”所述, 添加机油。

8-7. 添加润滑脂 (当出现“GREASEUP”时)

当电源开关打开时, 如果程序号 (No.) 表示 (1) 和菜单表示 (2) 所显示的“GrE”、“AS.UP”闪烁, 且蜂鸣器鸣响, 则意味着需要添加润滑脂。(此时, 即使踩下脚踏开关, 缝纫机也不工作。) 按需要添加润滑脂, 详情见下面。

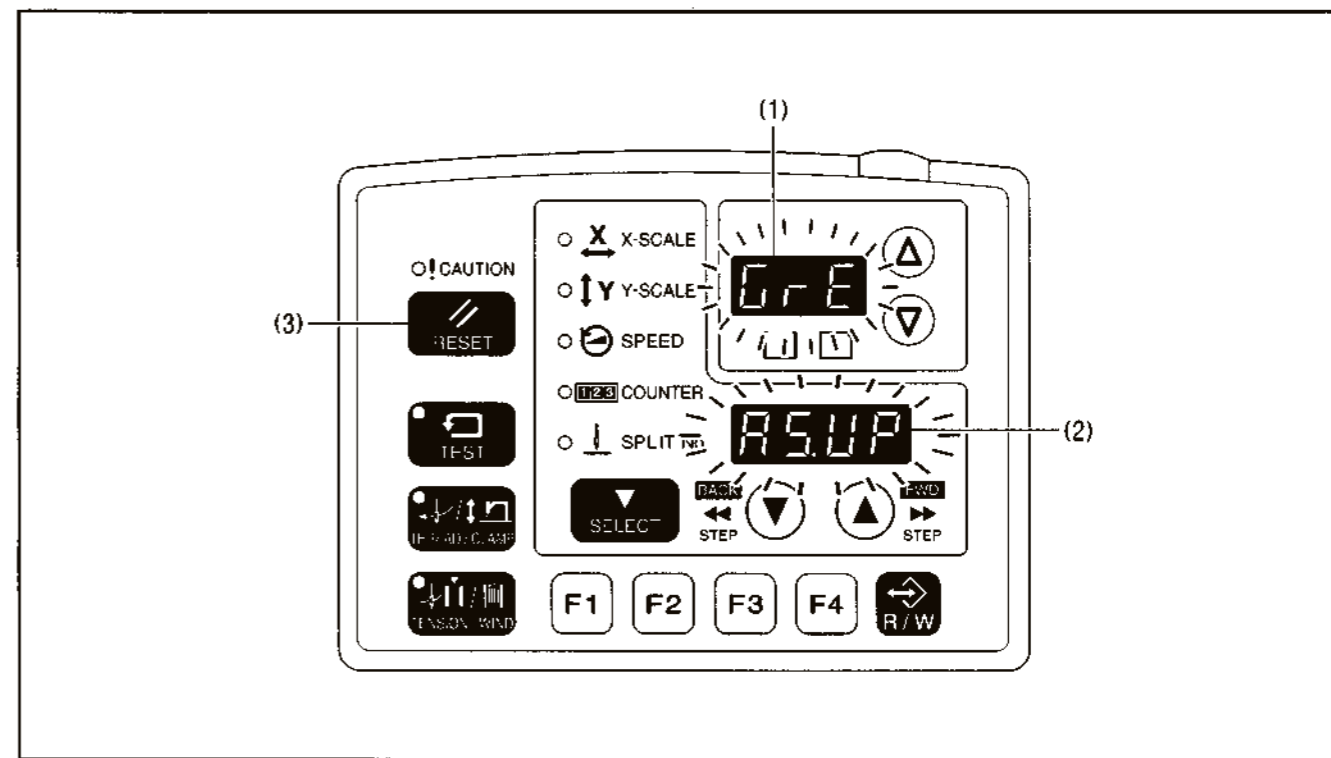

<暂时不添加润滑脂继续缝纫>

1. 按 RESET 键 (3)。
2. 程序号 (No.) 表示 (1) 和菜单表示 (2) 变为通常的显示, 如果踩下脚踏开关就可进行缝纫。

注意:

- 每次打开电源时, 如果显示“GrE”、“AS.UP”, 就请添加润滑脂并参照另纸所述执行复位操作。
- “GrE”“AS.UP”通知出现后如不添加润滑脂 (或不执行复位操作) 而继续使用缝纫机, 过一段时间后, “E100”将出现, 为安全起见, 缝纫机将强行停止工作。此时, 添加润滑脂并执行复位操作。

* 如果在不添加润滑脂的状态下进行复位操作并继续运转缝纫机, 则会造成缝纫机故障。

<添加润滑脂>

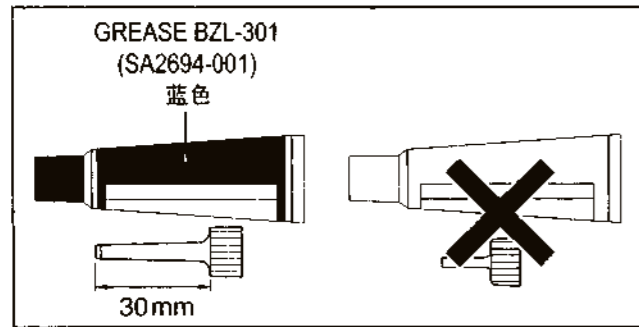

注意:

- 只使用规定的润滑脂 (GREASE BZL-301 (SA2694-001) 蓝色软管)。
 - 对于这种机型, 请不要使用 (GREASE BZL-300 (SA2355-001) 白色软管)。
 - 除了明确标示“请使用(GREASE BZL-301)”的机型外, 请不要使用 (GREASE BZL-301 (SA2694-001) 蓝色软管)。
- 润滑脂请购买“润滑脂组 (SA2693-001)”。

1. 使用导管

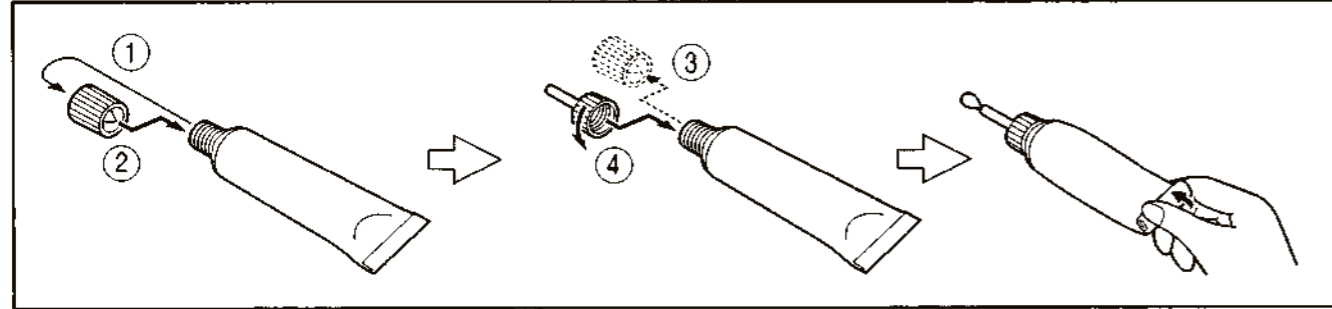

2. 添加润滑脂

按照下述方法, 给另纸上有箭头标记的部位添加润滑脂。

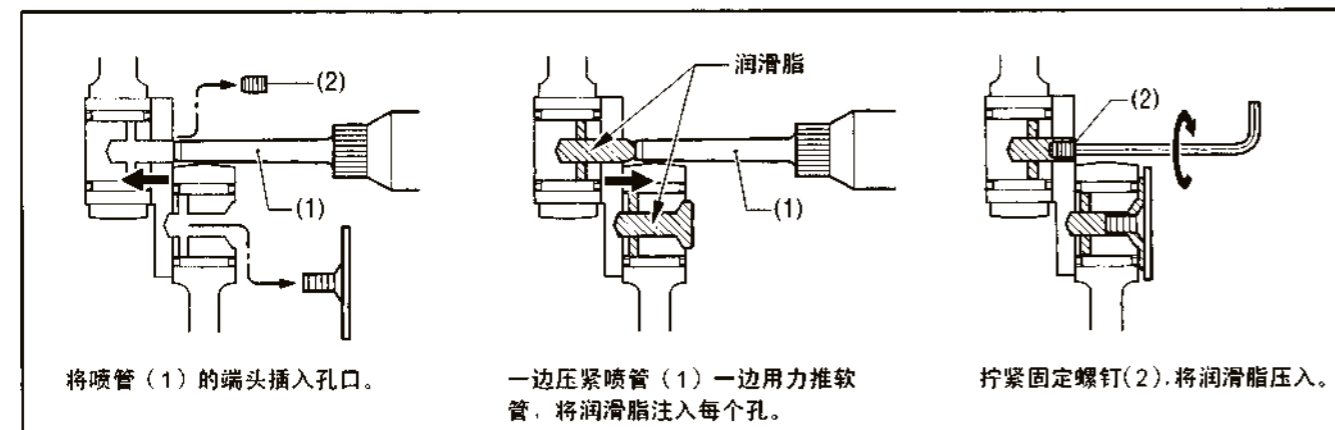

- 关闭电源开关。
- 拧下固定螺钉 (2)。需要添加润滑脂的部位, 请参照另纸。
- 用手转动缝纫机手轮使针杆上下运动, 与此同时向每个孔注入润滑脂直到润滑脂略微溢出。
- 通过拧紧固定螺钉 (2), 以将润滑脂压入。

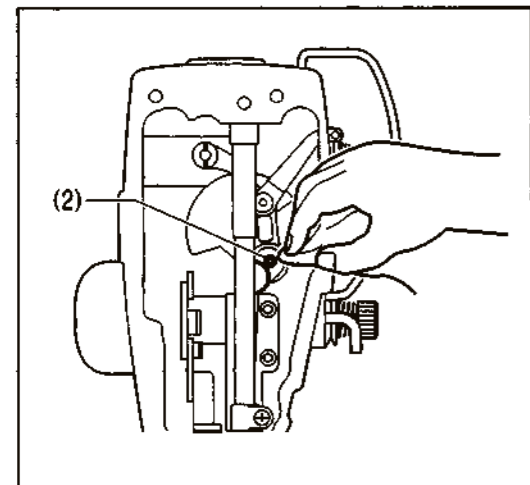

- 用手转动手轮, 上下移动针杆数次以便润滑脂散开。
- 用布擦去溢出在固定螺钉 (2) 周围的润滑脂。
- 以同样的方法, 给另纸上所示的各个部位添加润滑脂。
- 然后, 请参照另纸所述进行复位操作。

注意:

- 润滑脂开封后请从软管取下喷嘴, 盖紧盖子并保管在阴暗处。
- 请尽早将管内的润滑脂全部用完。
- 要再次使用时, 请先除去残留在喷嘴内旧的润滑脂, 然后再使用。

(开封后的润滑脂可能会老化变质, 从而不能充分发挥其性能, 因此, 请注意要保管好。)

9. 误码表

⚠危险

⚡ 打开控制箱盖时, 先关闭电源开关并将电源插头从插座上拔下后, 至少等待 5 分钟后, 再打开控制箱盖。触摸带有高电压的区域将会造成人员受伤。

当万一机器发生故障时, 蜂鸣器鸣响, 显示窗上显示误码。请按照处理方法来排除导致故障的原因。

开关方面的故障

错误代码	原因和解决方法
E026	脚踩开关被踩到第2档后一直保持在该位置。 关闭电源, 确认脚踩开关。
E035	脚踩开关被踩到第1档后一直保持在该位置。 关闭电源, 确认脚踩开关。
E050	在缝纫机头倒下的状态下踩下了脚踩开关, 或操作了操作盘; 或者在缝纫机启动中倒下了缝纫机头。
E051	关闭电源, 竖起缝纫机头。
E055	确认主基板插头的8号引脚的插入状况。
E065	打开电源时, 操作盘的开关处于按着状态或开关不良。 关闭电源, 确认操作盘。

主轴马达方面的故障

错误代码	原因和解决方法
E100	在显示“GREASEUP”后, 经过了一定时间仍不添加润滑脂 (不进行复位操作)。添加润滑脂, 执行复位操作。
E110	起针停止位置的故障。 转动手轮, 将钢印对准起针停止位置。
E121	线没有切断。 关闭电源, 确认固定刃、移动刃的刃部是否已经磨损。
E130	缝纫机马达异常停止了或同步器连接不良。 关闭电源, 转动手轮以确认缝纫机是否被锁住了。 确认电源马达基板插头的4号、5号引脚的插入状况。

送布方面的故障

错误代码	原因和解决方法
E200	不能检测X轴送布马达的原点。X轴送布马达异常或X轴原点传感器连接不良。 关闭电源, 确认PMD基板插头的10号引脚和主基板插头的2号引脚的插入状况。
E201	X轴送布马达异常停止了。 关闭电源, 确认X轴送布方向是否异常。
E202	X轴送布马达或Y轴送布马达的原点调整数据异常。 重新进行原点调整。
E210	不能检测Y轴送布马达的原点。Y轴送布马达异常或Y轴原点传感器连接不良。 关闭电源, 确认PMD基板插头的8号引脚和主基板插头的3号引脚的插入状况。
E211	Y轴送布马达异常停止了。 关闭电源, 确认Y轴送布方向是否异常。

9. 误码表

压脚方面的故障

错误代码	原因和处理方法
E300	不能检测压脚原点。压脚马达异常或压脚原点传感器连接不良。 关闭电源，确认PMD基板插头的3号引脚和主基板插头的4号引脚的插入状况。
E301	不能检测压脚的上升和下降。 关闭电源，确认压脚的上下方向有无异常。

通信或记忆存储器方面的故障

错误代码	原因和处理方法
E450	不能从机头存储器读取机型选择数据。 关闭电源，确认电源马达基板插头的3号引脚的插入状况。

数据编辑方面的故障

错误代码	原因和处理方法
E500	由于放大设置，缝纫数据超出了可缝纫范围。 再次设置放大倍率。
E501	读取了超出缝纫机可能缝纫范围的缝纫数据。 确认缝纫数据的大小。
E502	由于放大设置，数据间隔超出了最大间隔值12.7mm。 再次设置放大倍率。
E530	禁止变更程序号。

装置方面的故障

错误代码	原因和处理方法
E690	线夹原点不正确。 关闭电源，清除针板里侧的棉尘。 确认主基板插头的12号引脚的插入状况。
E691	线夹退避位置不正确。 确认面线残留量是否太长。 关闭电源，清除针板里侧的棉尘。 确认主基板插头的12号引脚的插入状况。

基板方面的故障

错误代码	原因和处理方法
E700	电源电压异常升高。 关闭电源，确认输入电压。
E705	电源电压异常下降。 关闭电源，确认输入电压。
E740	冷却风扇不工作。 关闭电源，确认是否被线屑等缠住了。 确认主基板插头的18号引脚的插入状况。

如果出现上面没有列出的错误代码，请与经销商联系。